

CAUTION: DISCONNECT ELECTRIC CURRENT BEFORE SERVICING

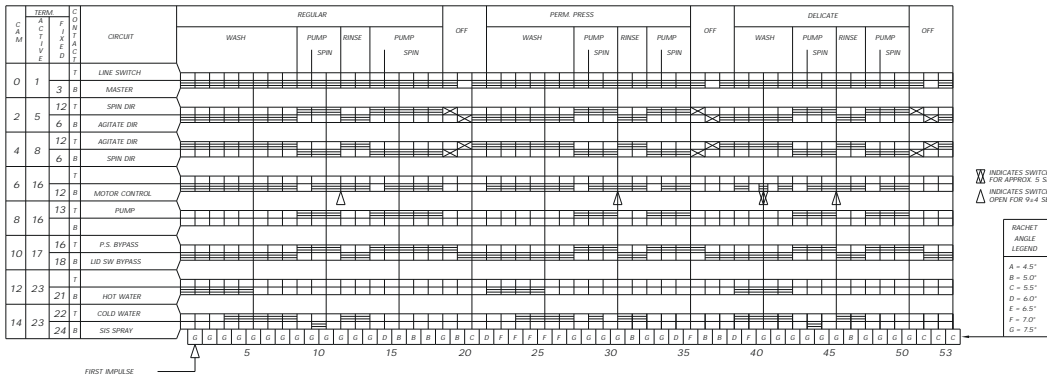

CIRCLED NUMBERS INDICATE CAM

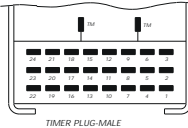
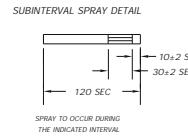
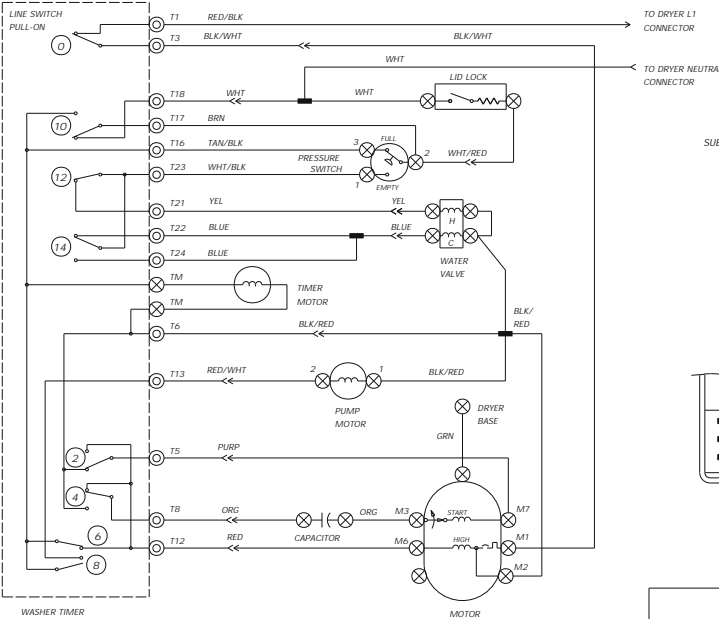

**WIRING CODES**

- ⊙ PLUG-IN TIMER
- ⊗ QUICK DISCONNECT TERMINAL
- CONNECTION
- + NO CONNECTION
- ⊕ MOTOR SWITCH
- ⊞ SPLICE
- ⊞ MOTOR PROTECTOR
- ⊞ CHASSIS (CABINET) GROUND
- ⊞ SCREW TERMINAL
- ⊞ HARNESS CONNECTOR TERMINAL
- ⊞ INSULATED TERMINAL

- NOTES:**
- ALL WIRING MUST CONFORM TO LOCAL ELECTRICAL CODES.
  - CONNECT DRYER TO 30 AMP INDIVIDUAL BRANCH CIRCUIT.
  - DRYER TIMER SHOWN IN OFF POSITION. DOOR SWITCH CLOSED, MOTOR AT REST, AN THERMOSTAT CLOSED.
- WASHER TIMER SHOWN IN ON POSITION AND PRESSURE SWITCH FULL.

**CYCLES**

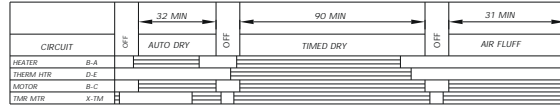

BAR CHART ABOVE REPRESENTS ONE COMPLETE REVOLUTION OF TIMER SHAFT.

SHADED PORTION OF BAR CHART INDICATES THE PROPORTIONAL TIMES THAT INTERNAL TIMER CONTACTS ARE CLOSED.

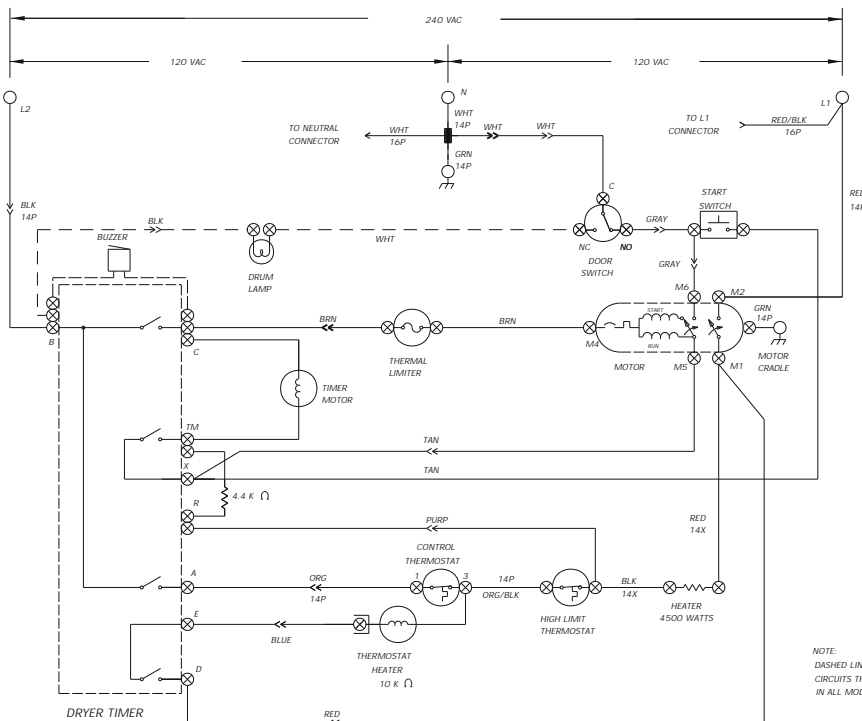

**WIRE SPECIFICATIONS**

CODE	WIRE GAUGE A.W.G.	INSULATION MATERIAL
18P	18	105°C PVC (POLYVINYLCHLORIDE)
16P	16	
14P	14	125°C X-LINK
14X	14	

NOTE: ALL UNSPECIFIED WIRE CODES ARE 18P.

NOTE: DASHED LINES INDICATE CIRCUITS THAT ARE NOT IN ALL MODELS.