

Whirlpool[®] CORPORATION 30" Drop-in Electric Range

PRODUCT MODEL NUMBERS

RS610PXG
RS675PXG

Electrical: Connect with 8-gauge solid copper wire. Models rated from 11.8 kW to 13.3 kW at 240 volts (8.9 kW to 10.0 kW at 208 volts) require a separate 40-ampere circuit, fused on both sides of the line. A separate circuit is required. A time-delay fuse or circuit breaker is recommended.

OVERALL DIMENSIONS

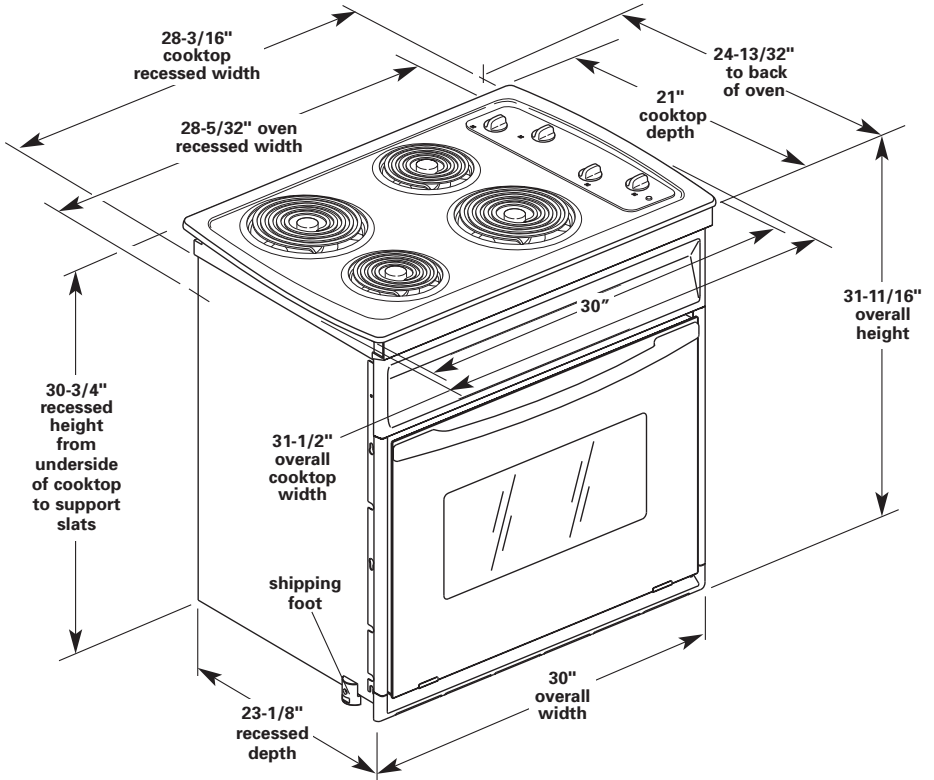

COUNTERTOP PREPERATION

Front edges: You may need to shave or cut the trim of formed or metal front-edged countertops to clear the 30" width of cooktop.

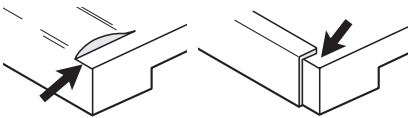

If countertop thickness is more than 1-1/2" inches thick: Countertop must be notched as shown to avoid damaging the oven control panel.

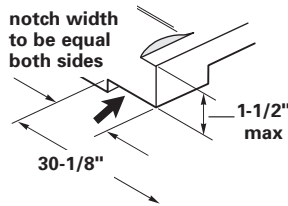

If countertop extends more 1-1/8" beyond cabinet front: Notch countertop as shown to clear oven control panel.

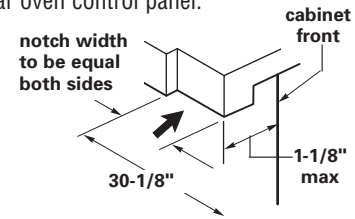

CABINET OPENING DIMENSIONS

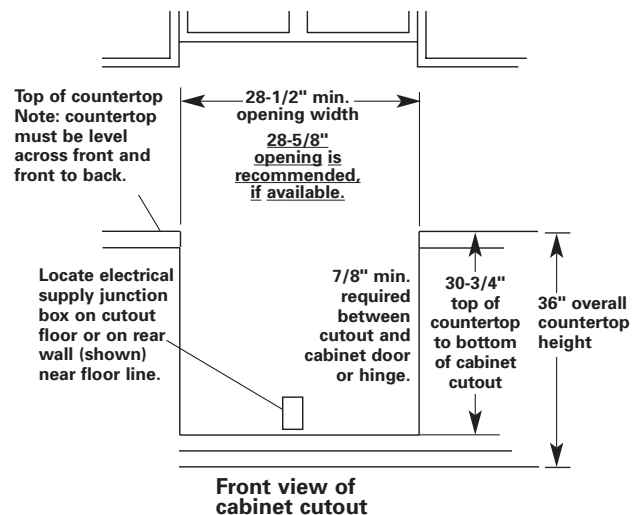
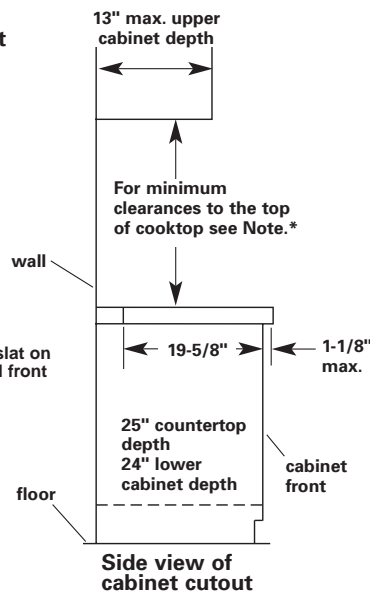
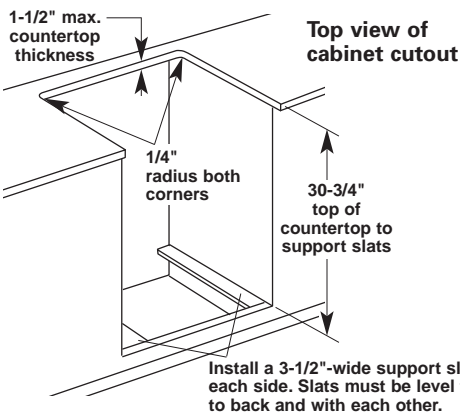

* Note: 24" min. when bottom of wood or metal cabinet is protected by not less than 1/4" flame retardant millboard covered with not less than No. 28 MSG sheet steel, 0.015" stainless steel, 0.024" aluminum or 0.020" copper.

30" min. clearance between the top of the cooking platform and the bottom of an unprotected wood or metal cabinet.