

Exploded View of Wash System

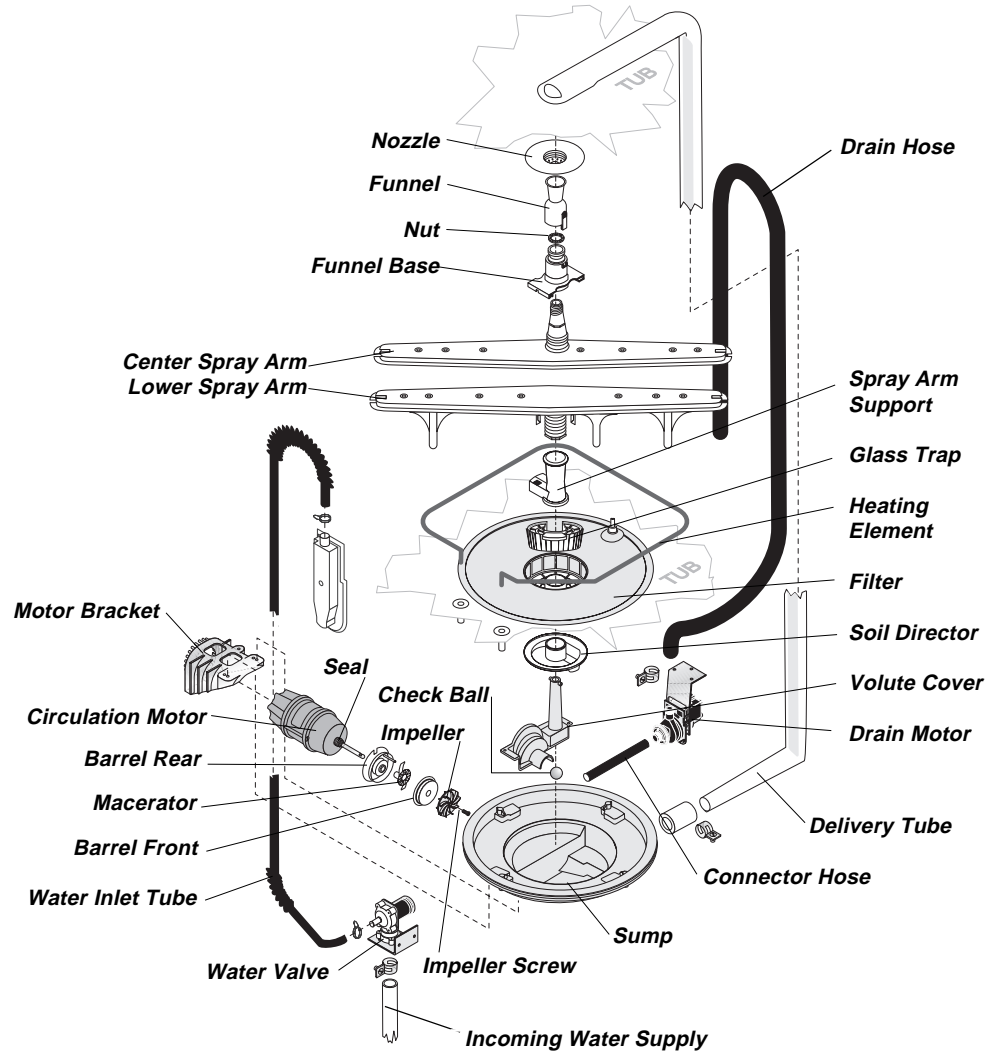

Pump Assembly

The pump assembly is driven by a 1/12 HP, shaded pole motor. Rotation is in the counterclockwise direction at 3100 to 3200 RPM. The motor drives a pump which supplies 100 percent filtered water at a rate to approximately 12 GPM to one spray arm at a time. The spray arm's operation is alternated by small "pauses" of the motor during the wash cycle.

Draining is accomplished by using a small separate synchronous drain pump mounted to the side of the sump. The drain pump is connected to the main pump by a small rubber hose. The drain check valve is located at the entrance to the drain pump. The drain hose is attached by a worm gear clamp to the discharge of the drain pump. The drain is then routed up the side of the dishwasher and attached to the side of the tub. This drain loop insures that an air pocket cannot form near the drain pump and cause the pump to

air lock. The drain loop on the side of the tub must be kept in place after servicing.

The main pump can easily be removed by disconnecting the upper spray arm supply tube, the drain pump connector hose, and the wiring harness connections made at the circulation motor and the water heat thermostats located on the bottom of the pump.

Once the pump assembly is removed from the dishwasher, the motor/impeller assembly can be removed from the sump by taking out the three (3) T-20 Torx head screws from the aluminum motor bracket and then the three (3) T-20 Torx head screws from the volute cover. Using a large flat head screwdriver inserted between the impeller screw and the sump's volute, the motor/impeller assembly can be gently pried out of the sump. Use the screwdriver as a lever.

900 Watt Heater

Refer to the cycle chart on the reverse side to determine when the heater is on during the wash cycle. The heater cycles **ON** and **OFF** for brief periods during the drying cycle.

Voltage checks of the heater should be made with the timer set in the main wash.

Standard Dry Air Flow

When the control advances to the "dry" portion of the cycle, a linear actuator retracts a valve, which opens a vent path through the console into the kitchen. This venting method eliminates discharging heated moisture into the motor compartment. The heated, moist air leaving the dishwasher through the console vent causes drier air to be drawn into the unit by way of intake vents located at the bottom of the door. The water on the dishes is evaporated into drier air and the venting process continues. The heating element is turned **ON** and **OFF** during the entire drying cycle.

Detergent and Rinse Aid Dispenser

The detergent and rinse aid dispenser is a one piece component consisting of a molded detergent cup and a built-in rinse aid dispenser.

The detergent cup has a spring loaded cover and the rinse aid dispenser has a removable cover.

Liquid rinse aid is added to the dispenser up to the fill line indicator. The amount of rinse aid released can be adjusted by turning the arrow indicator from one, being the least amount, to four, being the greatest amount.

To replace dispenser:

- shut off electricity to dishwasher,
- remove outer door panel assembly,
- disconnect wiring to the actuator,

Power Dry Air Flow

The Power Dry configuration is the same as the Standard except it has a cross flow blower located in the air discharge path. The blower assists the heating element in producing power to drive the moist air out of the dishwasher.

- remove the six screws,
- remove the dispenser,
- replace and reinstall screws,
- rewire actuator.

To replace actuator:

- shut off electricity to dishwasher,
- disconnect wiring to the actuator,
- place a flat head screwdriver under the actuator body and between the dispenser housing and terminal side, twist and lift up on the actuator being careful not to damage the retainer snap-fits,
- replace with new actuator by pressing into place,
- rewire actuator.

Tub and Door Seal

The door seal is pressed into the tub channel for an interference fit. Center the gasket (marked on back) at the tub top center and press in place

without stretching or bunching. The gasket takes a short turn at the bottom of the tub channel before ending at the channel end wall.

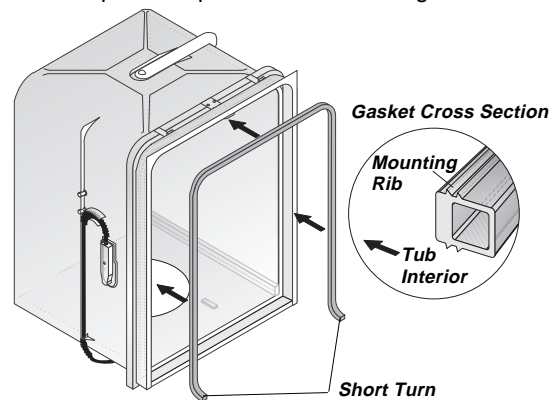

Product Specifications

Electrical

Rating	120 Volts, 60Hz
Separate Circuit..	15 amp min.- 20 amp max.
Motor (HP)	1/12
Motor (Amps)	3.4
Heater Wattage	900
Total Amps (load rated)	11.0
TempAssure (some models)	117°F±5°F (47°C±3°C) [with outer door in place]
TempBoost (some models)	127°F (53°C)
	Heated Wash/Heated Rinse
Hi-Limit Thermostat	200°F (93°C)

Water Supply

Suggested minimum incoming water temperature	120°F (49°C)
Pressure (PSI) min./max.	20/120
Connection (NPT)	3/8"
Consumption (Normal Cycle)	6.0 U.S. gal., 5.0 Imp. gal., 22.7 liters
Water valve flow rate (U.S. GPM)83
Water recirculation rate (U.S. GPM)	approx. 12
Water fill time	87 sec.

Trouble Shooting Tips

WARNING

Personal Injury Hazard

Always disconnect the dishwasher from the electrical power source before adjusting or replacing components.

Symptom	Check the Following	Remedy
Dishwasher will not operate when turned on (wait at least 90 seconds).	<ol style="list-style-type: none"> 1. Fuse (blown or tripped). 2. 120 VAC supply wiring connection faulty. 3. Timer (contacts open or defective) 4. Motor (inoperative, check resistances). 5. Door switch (open contacts). 6. Door latch not making contact with door switch. 7. Selector switch (open contacts). 	<ol style="list-style-type: none"> 1. Replace fuse or reset breaker. 2. Repair or replace wire fasteners at dishwasher junction box. 3. Replace timer. 4. Replace motor/impeller assembly. 5. Replace door switch. 6. Replace latch assembly. 7. Replace selector switch.
Motor hums but will not start or run.	<ol style="list-style-type: none"> 1. Motor (bad bearings or locked rotor). 2. Motor stuck due to prolonged non-use. 	<ol style="list-style-type: none"> 1. Replace motor. 2. Rotate motor fan or impeller.
Motor trips out on internal thermal overload protector.	<ol style="list-style-type: none"> 1. Improper voltage. 2. Seal faces binding. 3. Motor shaft binding. 4. Motor windings shorted. 5. Glass or foreign items in pump. 	<ol style="list-style-type: none"> 1. Check voltage. 2. Rotate motor fan or impeller, or replace. 3. Clear blockage or replace. 4. Replace motor/impeller assembly. 5. Clean and clear blockage.
Dishwasher runs but will not heat.	<ol style="list-style-type: none"> 1. Heater element (open). 2. Timer defective. 3. Wiring or terminal defective. 4. Hi-limit thermostat defective. 	<ol style="list-style-type: none"> 1. Replace heater element. 2. Replace timer. 3. Repair or replace. 4. Replace thermostat.
Detergent cover will not latch or open.	<ol style="list-style-type: none"> 1. Latch mechanism defective. 2. Timer contact defective. 3. Wiring or terminal defective. 4. Broken spring(s). 5. Defective actuator. 	<ol style="list-style-type: none"> 1. Replace dispenser. 2. Replace timer. 3. Repair or replace. 4. Replace dispenser. 5. Replace actuator.
Dishwasher will not pump out.	<ol style="list-style-type: none"> 1. Drain restricted. 2. Timer contact defective. 3. Defective drain pump. 4. Air lock in drain hose. 5. Blocked impeller. 6. Open windings. 	<ol style="list-style-type: none"> 1. Clear restrictions. 2. Replace timer. 3. Replace pump. 4. Make sure hose is attached in proper position on side of tub. 5. Check for blockage, clear. 6. Replace windings.
Dishwasher will not fill with water.	<ol style="list-style-type: none"> 1. Water supply turned off. 2. Defective water inlet fill valve. 3. Check fill valve screen for obstructions. 4. Defective float switch. 5. Timer contact defective. 6. Wiring defective. 7. Float stuck in "UP" position. 	<ol style="list-style-type: none"> 1. Turn water supply on. 2. Replace water inlet fill valve. 3. Disassemble and clean screen. 4. Repair or replace. 5. Replace timer. 6. Repair or replace. 7. Clean float.
Timer does not advance.	<ol style="list-style-type: none"> 1. Timer motor (stalled or open.) 2. Check timer for power to timer motor. 3. Timer shaft binding to or knob interference with escutcheon. 4. TempBoost thermostat defective. 	<ol style="list-style-type: none"> 1. Replace timer. 2. Repair or replace timer. 3. Repair or adjust. 4. Replace or adjust position of thermostat.
Dishwasher water siphons out.	<ol style="list-style-type: none"> 1. Drain hose (high) loop too low. 2. Drain line connected to a floor drain not vented. 3. Drain hose not connected to side of tub. 	<ol style="list-style-type: none"> 1. Repair to proper height. 2. Install air gap at counter top. 3. Reattach drain hose.
Detergent left in dispenser.	<ol style="list-style-type: none"> 1. Detergent allowed to stand too long in dispenser. 2. Dispenser wet when detergent was added. 3. Detergent cover held closed or blocked by large dishes. 4. Improper incoming water temperature to properly dissolve detergent. 5. See "Detergent cover will not open." 	<ol style="list-style-type: none"> 1. Instruct customer/user. 2. Instruct customer/user. 3. Instruct customer/user on proper loading of dishes. 4. Incoming water temperature of 120°F is required to properly dissolve dishwashing detergents.

SERVICE DATA SHEET

This information is intended for use by persons having electrical and mechanical training and a level of knowledge acceptable in the appliance repair trade. Frigidaire Company cannot be responsible, nor assume any liability, for injury or damage of any kind arising from the use of this Service Data Sheet.

P/N: 154295401

FRIGIDAIRE
Model: **FDB421**

Color Code

- BK..... Black
- BK-W..... Black/White
- BK-Y..... Black/Yellow
- BR..... Brown
- BR-W..... Brown/White
- BU..... Blue
- BU-O..... Blue/Orange
- O..... Orange
- O-BK..... Orange/Black
- O-W..... Orange/White
- PK..... Pink
- PK-BK..... Pink/Black
- PK-W..... Pink/White
- R..... Red
- R-BK..... Red/Black
- R-W..... Red/White
- R-Y..... Red/Yellow
- VIO..... Violet
- W..... White
- Y..... Yellow
- Y-BK..... Yellow/Black

Timer Block

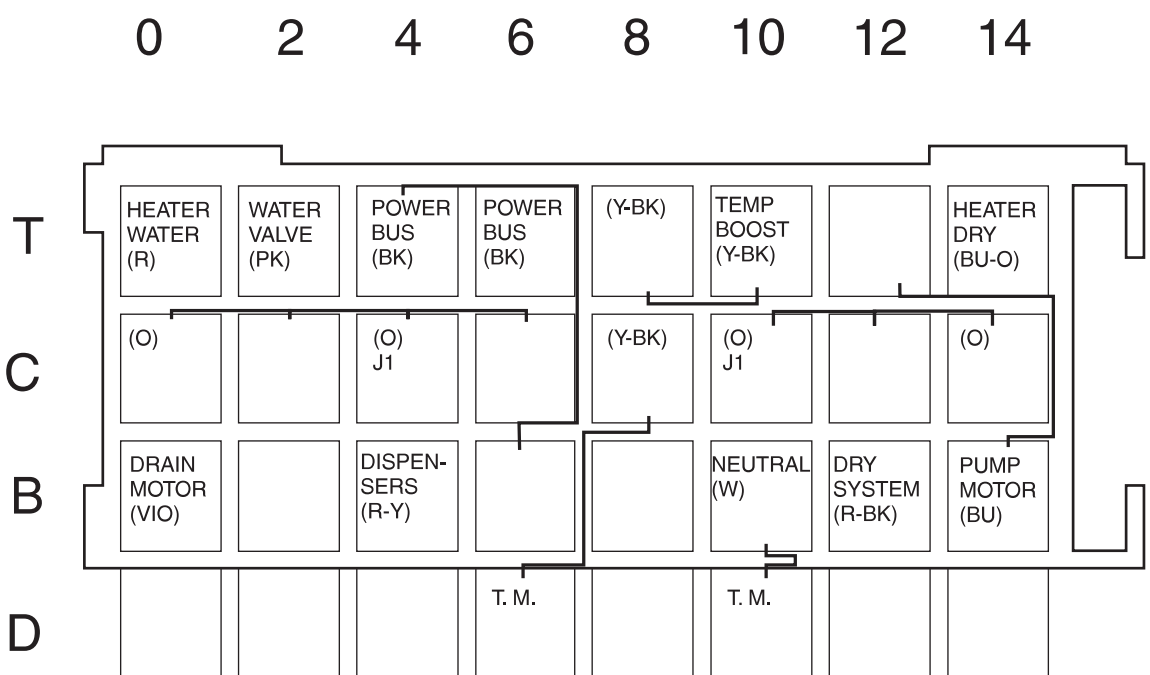

Cycle Chart

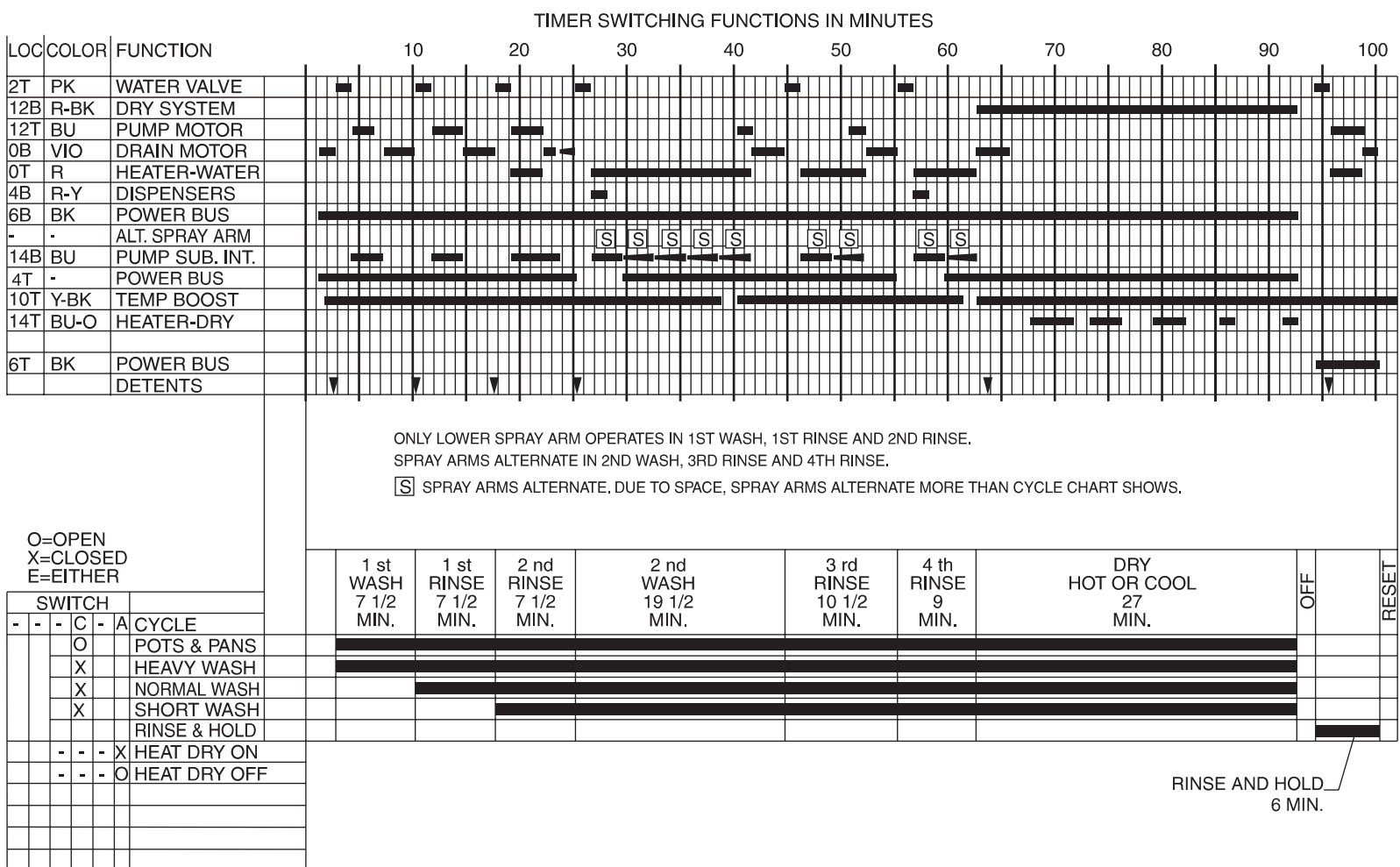

Wiring Diagram

