

Installation Instructions

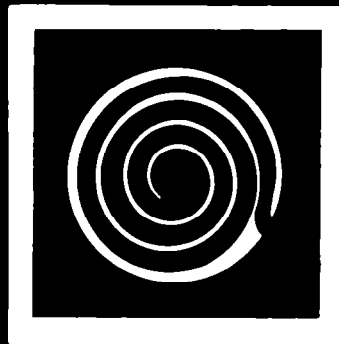

for
your new



Whirlpool

**Electric Built-In
Cook Top**

BEFORE YOU BEGIN read the following instructions completely and carefully. If followed they will simplify the installation job.

IMPORTANT: OBSERVE ALL GOVERNING CODES AND ORDINANCES

SAVE THESE INSTRUCTIONS FOR THE LOCAL ELECTRICAL INSPECTOR'S USE

STEP 1

CARPENTRY

See Figure 1 for the dimensions of typical counter top cut-out. The cut-out must be located so that when the cook top is set in place there is at least one (1) inch between the rear edge of the cook top and any combustible surface above the counter top. It is also recommended that a six (6) inch space be left between the side(s) of the cook top and any vertical wall or cabinet extending above the upper edge of the cook top. This built-in cook top has a shallow burner box (3") which allows the unit to be mounted above cabinet drawers that are more than 3 inches below the top of the counter top.

STEP 2

ELECTRICAL REQUIREMENTS

A. A three-wire or four-wire single phase 120/240 volt 60 Hz AC only electrical supply (or three-wire or four-wire 120/208 volt if specified on nameplate) is required on a separate circuit fused on both sides of the line (time-delay fuse or circuit breaker is recommended). Do NOT fuse neutral. The fuse size must not exceed the circuit rating of the appliance specified on the nameplate.

NOTE: Wire sizes and connections must conform with the fuse size and rating of the appliance in accordance with the National Electrical Code and local codes and ordinances. Do not use an extension cord.

B. The appliance should be connected to the fused disconnect (or circuit breaker) box through flexible armored or non-metallic sheathed cable. The flexible armored cable extending from the appliance should be

connected directly to the junction box. The junction box should be located as shown in Figure 1 so that as much slack as possible remains in the cable between the box and the appliance so that it can be moved if servicing is ever necessary.

C. A suitable strain relief must be provided to attach the flexible armored cable to the junction box.

STEP 3

ELECTRICAL CONNECTION

First lay a piece of cardboard (packing carton) about the size of the built-in cook top (20" x 30") on the counter top adjacent to the cut-out for protection to the finish of the counter top. Second, place the built-in cook top on the cardboard. Next connect the flexible armored cable that extends from the surface unit to the junction box using a suitable strain relief at the point the armored cable enters the junction box. Then make the electrical connection as follows:

It is the personal responsibility and obligation of the customer to contact a qualified installer to assure that the electrical installation is adequate and is in conformance with the National Electrical Code and local code ordinances.

Electrical ground is required on this appliance.

This appliance is equipped with copper lead wires. If connection is made to aluminum house wiring, use only special connectors which are approved for joining copper and aluminum wires in accordance with the National Electrical Code and local codes and ordinances. This appliance is manufactured with a white neutral power supply wire and a frame connected green ground wire.

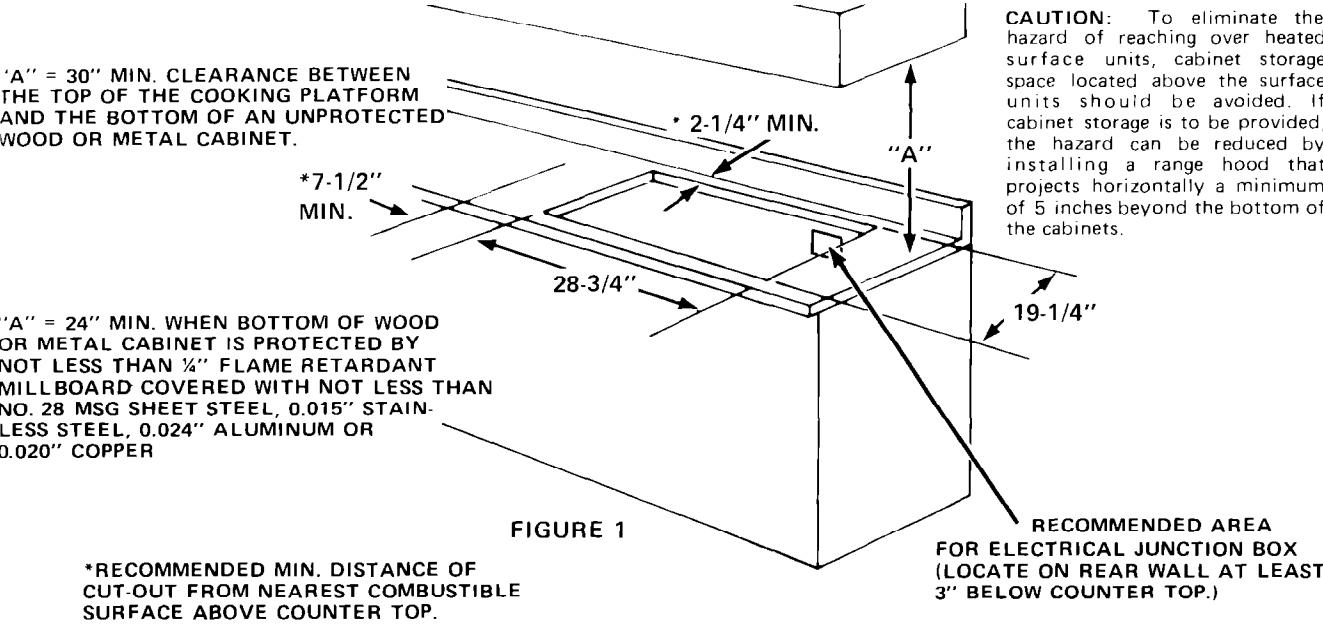

A. If local codes permit connection of the frame grounding conductor to the neutral (white wire), connect the green and white wire from the supply cable of the appliance together and to the neutral (white) wire in the junction box. Connect the remaining wires from the supply cable, matching the colors, to the wires in the junction box.

B. If local codes DO NOT permit frame grounding to the neutral, separate the white and green wires that extend out of the end of the supply cable of the appliance. Connect the white wire from the supply cable to the neutral wire in the junction box.

Connect the black and red wire from the supply cable, matching the colors, to the corresponding wires in the junction box. The green wire MUST now be used to ground the appliance in accordance with local electrical codes. Connect the green ground wire to a grounded cold water pipe* or to the grounded lead in the service panel. **Do not ground to a gas supply pipe.** Do not connect to electrical power supply until appliance is permanently grounded. Connect the ground wire before turning on the power. See Figure 2.

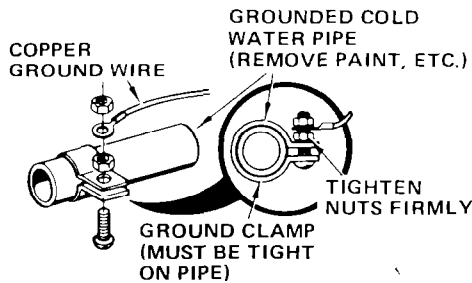

FIGURE 2

*Cold water pipe must have metal continuity to electrical ground and not be interrupted by plastic, rubber or other electrically insulating connectors (including water meter or pump) without adding a jumper wire at these connections.

CAUTION: If connecting to a four-wire electrical system (MOBILE HOME) the appliance frame **MUST NOT** be connected to the neutral wire of the four-wire electrical system. Separate the white and green wires that extend out of the end of the supply cable of the appliance. Connect the white red and black wires from the supply cable, matching the colors, to the corresponding wires in the junction box. Connect the green wire from the supply cable to the ground wire in the junction box.

STEP 4

INSTALL SURFACE UNIT IN COUNTER TOP CUT-OUT

Set the built-in cooktop into the countertop cutout. Remove the shipping clip from each of the 4 surface units. The clips are for shipping only. Lift the clip with pliers or screwdriver. Then bend the clip to a vertical position. See Figure 3.

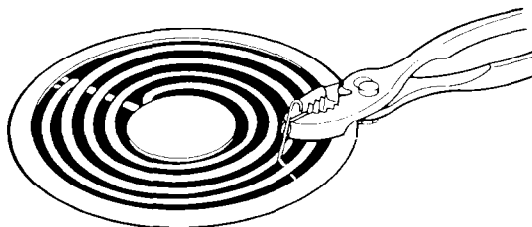
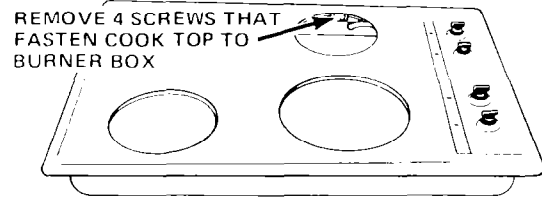

FIGURE 3

Then, remove all the surface units and bowls. Remove clip and discard. Also, remove tape from the control knobs, then remove four screws that fasten cook top to burner box. See Figure 4.

NOTE: REMOVE ALL SURFACE UNITS AND BOWLS



STEP 5

FIGURE 4

FASTEN BURNER BOX TO COUNTER TOP

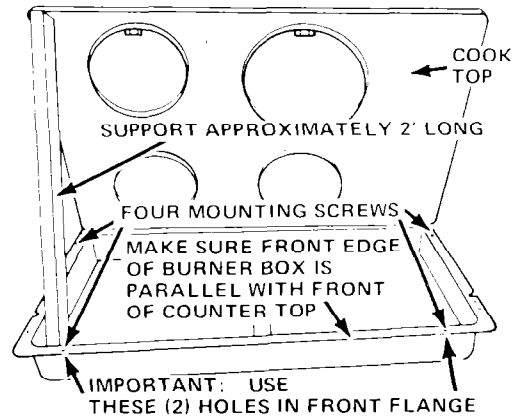
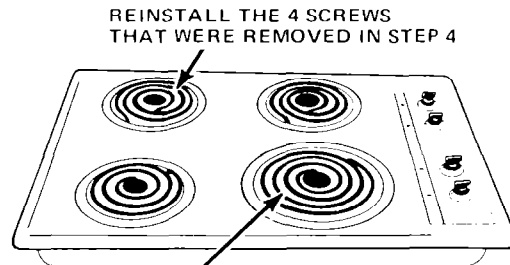

FIGURE 5

Lift front edge of cook top and pivot it away from burner box. Support the lifted top as shown in Figure 5. Next, locate the burner box so that it is parallel with the front edge of the counter top. Then, using the holes as shown in the burner box top flanges as templates, drill four 3/32 inch mounting screw holes. Secure the burner box to the counter top with the four screws that are provided in the parts bag. It is important to use the two holes in burner box front flange as shown.

STEP 6

FASTEN COOK TOP TO BURNER BOX



AFTER COOK TOP IS FASTENED TO BURNER BOX, REPLACE ALL SURFACE UNITS & BOWLS

FIGURE 6

Reposition the cook top on the burner box. Then, reinstall the four screws that secure the cook top to the burner box. See Figure 6. Replace all surface units and bowls.

You are now ready to turn the electrical power "ON".

C H E C K O P E R A T I O N

REFER TO USE AND CARE GUIDE PACKAGED WITH THE BUILT-IN COOK TOP TO CHECK FOR PROPER CARE AND CLEANING OF YOUR BUILT-IN COOKTOP.

CAUTION: Do not touch the elements. They may be hot and you may get burned.

1. Turn on each of the four (4) surface elements and check to see that they heat. On models so equipped check the surface element indicator light(s).

B E F O R E Y O U C A L L F O R S E R V I C E

CHECK TO MAKE SURE THE HOUSE FUSE OR CIRCUIT BREAKER FOR YOUR BUILT-IN COOK TOP IS NOT BLOWN OR OPEN.

MAKE SURE THE SURFACE ELEMENTS ARE PROPERLY PLUGGED INTO THEIR RECEPTACLES.

MY SELLING DEALER

NAME _____

ADDRESS _____

PHONE _____



In the event your WHIRLPOOL appliance should need service, call the dealer from whom you purchased the appliance or a WHIRLPOOL franchised TECH-CARE[®] service company. He is in the Yellow Pages of your telephone directory listed under Washers, Dryers—Repairing or Servicing. You can also obtain his name and number by dialing, free, within the continental United States (except Alaska) the Whirlpool COOL-LINE[®] Service (800) 253-1301 (when calling from Michigan, dial (800) 632-2243; from Alaska or Hawaii, dial (800) 253-1121). Dial just as you normally dial long distance. A special operator will tell you the name and number of your nearest Whirlpool TECH-CARE service outlet. During normal working hours, Whirlpool consultants at this same number will also answer any questions about operating or maintaining your appliance not covered in your Operating Instructions.

Learn the benefits of using TECH-CARE service for maintaining the quality originally built into your WHIRLPOOL appliance.

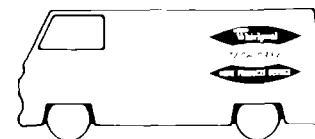

WHIRLPOOL CORPORATION • BENTON HARBOR, MICHIGAN • 49022