SERVICE DATA SHEET

318047478 (1008) Rev. A

Appliance with Electronic Oven Control

NOTICE

This service data sheet is intended for use by persons having electrical and mechanical training and a level of knowledge of these subjects generally considered acceptable in the appliance repair trade. **The manufacturer cannot be responsible, nor assume any liability, for injury or damage of any kind arising from the use of this data sheet.**

SAFE SERVICING PRACTICES

To avoid the possibility of personal injury and/or property damage, it is important that safe servicing practices be observed. The following are some, but not all, examples of safe practices.

1. Do not attempt a product repair if you have any doubts as to your ability to complete it in a safe and satisfactory manner.
2. Before servicing or moving an appliance, remove power cord from electric outlet, trip circuit breaker to Off, or remove fuse.
3. Never interfere with the proper installation of any safety device.
4. USE ONLY REPLACEMENT PARTS SPECIFIED FOR THIS APPLIANCE. SUBSTITUTIONS MAY DEFEAT COMPLIANCE WITH SAFETY STANDARDS SET FOR HOME APPLIANCES.
5. GROUNDING: The standard color coding for safety ground wires is GREEN OR GREEN WITH YELLOW STRIPES. Ground leads are not to be used as current carrying conductors. IT IS EXTREMELY IMPORTANT THAT THE SERVICE TECHNICIAN REESTABLISH ALL SAFETY GROUNDS PRIOR TO COMPLETION OF SERVICE. FAILURE TO DO SO WILL CREATE A POTENTIAL HAZARD.
6. Prior to returning the product to service, ensure that:
 - All electric connections are correct and secure.
 - All electrical leads are properly dressed and secured away from sharp edges, high-temperature components, and moving parts.
 - All uninsulated electrical terminals, connectors, heaters, etc. are adequately spaced away from all metal parts and panels.
 - All safety grounds (both internal and external) are correctly and securely reassembled.
 - All panels are properly and securely reassembled.

IMPORTANT NOTES

1. This unit includes an Electronic Oven Control board.
2. The included board is not field repairable.
3. The oven temperature can be calibrated, see Use and Care Manual.
4. The ■ pin on board connectors indicates pin number 1.

DATA SHEET ABBREVIATIONS AND TERMINOLOGY

EOC : Electronic Oven Control
LED : Light-Emitting Diode
MDL : Motor Door Latch
DLB : Double Line Break
RTD : Resistance Temperature Detector / Oven Probe

ILLUSTRATION OF OVEN CONTROLS

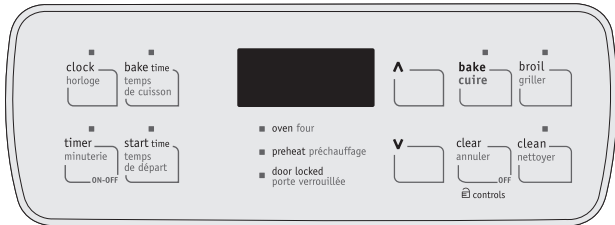
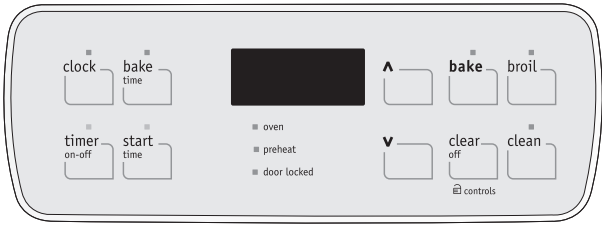

ELECTRONIC OVEN CONTROL (EOC)

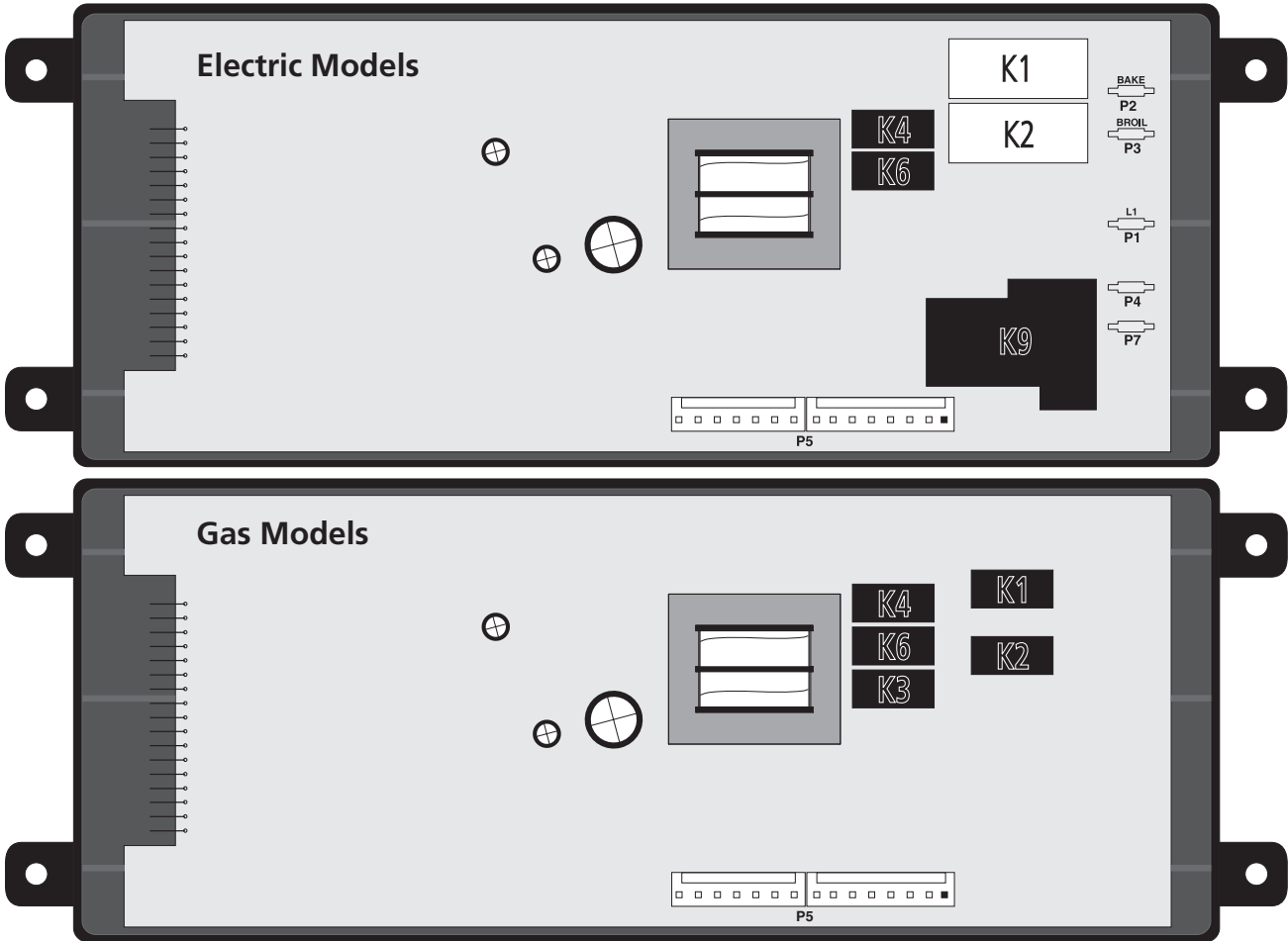

Electronic Oven Control Legend:

-All models
- K1. Bake Relay
- K2. Broil Relay
- K3. Cooling Fan Relay 1
- K4. Cooling Fan Relay 2
- K6. MDL Relay

-Electric models only
- K9. DLB Relay
- P1. L1 Fast-on Tab
- P2. Bake Fast-on Tab
- P3. Broil Fast-on Tab
- P4. DLB Out Fast-on Tab
- P7. DLB In Fast-on Tab

-P5 Connector Legend.....
- P5-1. Bake } Gas models only
- P5-2. Broil }
- P5-3. Cooling Fan Relay 1
- P5-4. L1 }
- P5-5. Neutral
- P5-6. MDL
- P5-7. Cooling Fan Relay 2
- P5-9. MDL Switch (Common)
- P5-10. MDL Switch (N/O)
- P5-11. MDL Switch (N/C)
- P5-12. RTD (Oven Probe)
- P5-13. RTD (Oven Probe)

ELECTRONIC OVEN CONTROL (EOC) FAULT CODE DESCRIPTIONS

Note: Generally speaking "F1x" implies a control failure, "F3x" an oven probe problem, and "F9x" a latch motor problem. In all occurrences the alarm is accompanied by a display of "F10".

F10	Control has sensed a potential runaway oven condition. Control may have shorted relay, RTD sensor probe may have gone bad.	- Check RTD sensor probe and replace if necessary. If oven is overheating, disconnect power. If oven continues to overheat when power is reapplied, replace EOC.
F11	Shorted Key: a key has been detected as pressed (for a long period) will be considered a shorted key alarm and will terminate all oven activity.	- Press CLEAR key. - If the problem persists, replace the EOC.
F13	Control's internal checksum may have become corrupted.	- Press CLEAR key. - Disconnect power, wait 10 seconds and reapply power. If fault returns upon power-up, replace EOC.
F30	Open RTD sensor probe/ wiring problem. Note: EOC may initially display an "F10", thinking a runaway condition exists.	- Some models are equipped with a safety thermostat connected in series with the oven probe. The F30 error might have been caused by the opening of the thermostat. It is possible the thermostat will close automatically once the unit had cooled down. Verify the operation of the cooling fan. - Check wiring in probe circuit for possible open or short condition. - Check RTD resistance at room temperature (compare to probe resistance chart). If resistance does not match the chart, replace the RTD sensor probe. - Let the oven cool down and restart the function. - If the problem persists, replace the EOC.
F31	Shorted RTD sensor probe / wiring problem.	
F90 to F94	Door motor mechanism failure.	- Turn off power for 10 seconds, then turn on power. Test the door latch again (try to start a Clean cycle). - If it fails check wiring of Lock Motor, Lock Switch and Door Switch circuits. - Unplug the lock motor from the board and apply power (L1) directly to the Lock Motor. If the motor does not rotate, replace Lock Motor Assembly. - Check Lock Switch for proper operation (do the contacts open and close, check with ohmmeter). The Lock Motor may be powered as in above step to open and close Lock Switch. If the Lock Switch is defective, replace Motor Lock Assembly. - If all above steps fail to correct situation, replace the EOC.

RTD SCALE		
Temp. °F	Temp. °C	Resistance (ohms)
32 ± 1.9	0.0 ± 1.1	1000 ± 4.0
75 ± 2.5	23.9 ± 1.4	1091 ± 5.3
250 ± 4.4	121.1 ± 2.4	1453 ± 8.9
350 ± 5.4	176.7 ± 3.0	1654 ± 10.8
450 ± 6.9	232.2 ± 3.8	1852 ± 13.5
550 ± 8.2	287.8 ± 4.6	2047 ± 15.8
650 ± 9.6	343.3 ± 5.3	2237 ± 18.5
900 ± 13.6	482.2 ± 7.6	2697 ± 24.4

ELECTRICAL RATING	
	30" Slide-In Range
Broil Element Wattage	2750W / 2065W
Bake Element Wattage	3400W / 2554W
KW Rating 240/208V	See serial plate

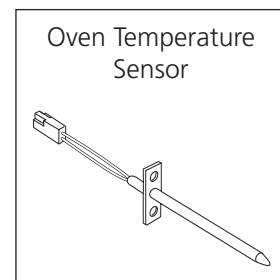

CIRCUIT ANALYSIS MATRIX								
					Lock Motor Switch A		Cooling Fan Relay 1 P5-7	Cooling Fan Relay 2** P5-3
	Bake P2* or P5-1	Broil P3* or P5-2	DLB P4*	MDL P5-6	Normally Open P5-9 & P5-10	Normally Closed P5-9 & P5-11		
Bake	X	X	X				X	
Broil		X	X				X	
Clean	X		X				X	X
UnLocked						X		
Locking				X				
Locked					X			
Unlocking				X				

* Electric Models only.

** Gas Models only.

BLOCK DIAGRAM FOR ELECTRIC MODELS

Electronic Oven Control ES300 or ES305

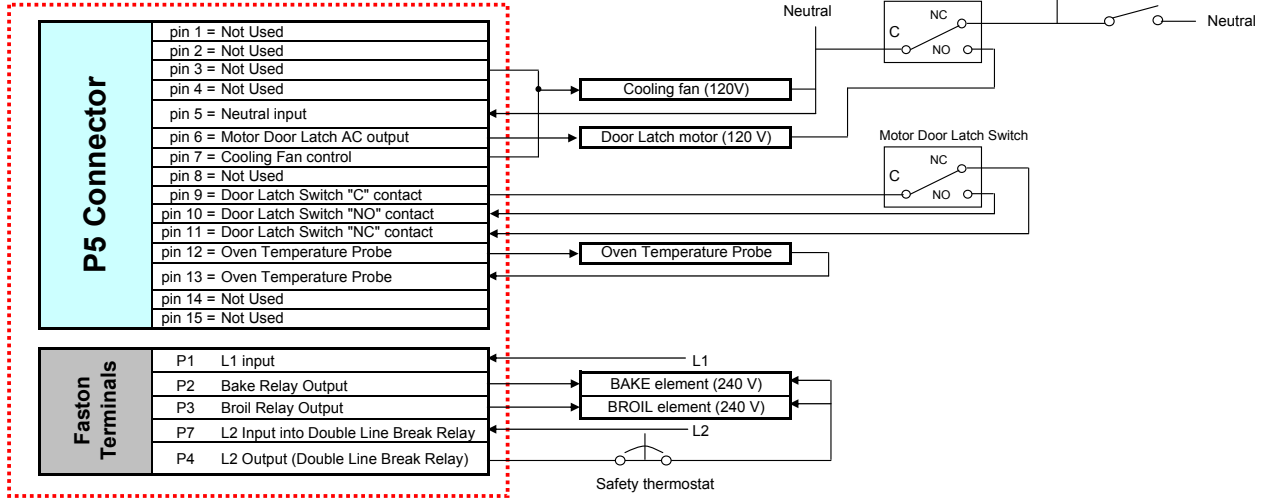

BLOCK DIAGRAM FOR GAS MODELS

Electronic Oven Control ES300 or ES305

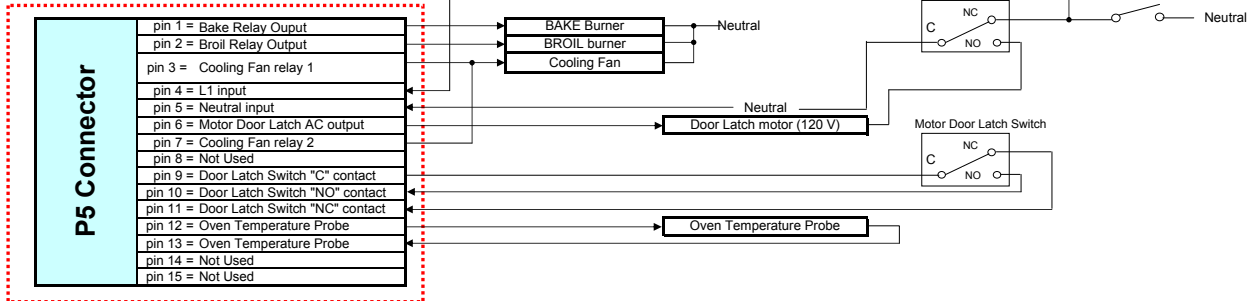

COOLING FAN

Electric Models: The EOC controls the speed of the cooling fan. It is activated during any cooking or cleaning function and will remain ON until the oven cools down.

Gas Models: The EOC controls the cooling fan using 2 relays (K3 and K4) but their output are tied together. K4 is activated during clean cycles when the oven is hot. K3 is used during any other function. The cooling fan will remain ON until the oven cools down.