



ELECTRIC DOWNDRAFT INSTALLATION GUIDE

IMPORTANT: Save for the local electrical inspector's use.

IMPORTANT: Read the Rules for Safe Use in your Use and Care Guide.

READ ALL INSTRUCTIONS BEFORE BEGINNING INSTALLATION

Follow these instructions step by step. If not installed according to these instructions the unit may not vent satisfactorily.

This unit is intended for indoor use only. Do not try to install the unit outdoors.

TOOL LIST

1. Flat bladed screwdriver
2. $1\frac{3}{8}$ " wrench
3. $\frac{3}{8}$ " deepwell socket wrench
4. Drill
5. Drillbits ($\frac{3}{16}$ " , $\frac{3}{8}$ ")
6. Hand or sabre saw
7. Duct tape
8. Hacksaw
9. File
10. Pencil
11. Ruler
12. Straightedge
13. Sheet metal screws

STEP 1: CHOOSING A LOCATION

- The height from the floor to the top of the counter must be at least $35\frac{7}{8}$ ".
- Consider all required minimum dimensions and recommended location for the electrical outlet (Figures 1 and 2).
- Downdraft units have their own venting system which must be ducted to the outside. The duct run from your chosen location must not exceed the maximum allowable duct run. Read the ducting information in Step 4 and plan the ducting before beginning this installation.
- Household heating and air conditioning outlets and fans could decrease the efficiency of the venting system if they are too close to, or directed toward, the unit. Do not put the range near an outside door or where a draft may affect venting performance.
- To avoid having to reach over heated surface units, cabinet storage space directly above the range should not be used, thus eliminating the risk of burns or fire. Cabinets installed above the unit may be no deeper than 13".

WARNING

To reduce the risk of ignition of surrounding combustible materials install three inches from rear wall. Install in accordance with manufacturer's instructions.

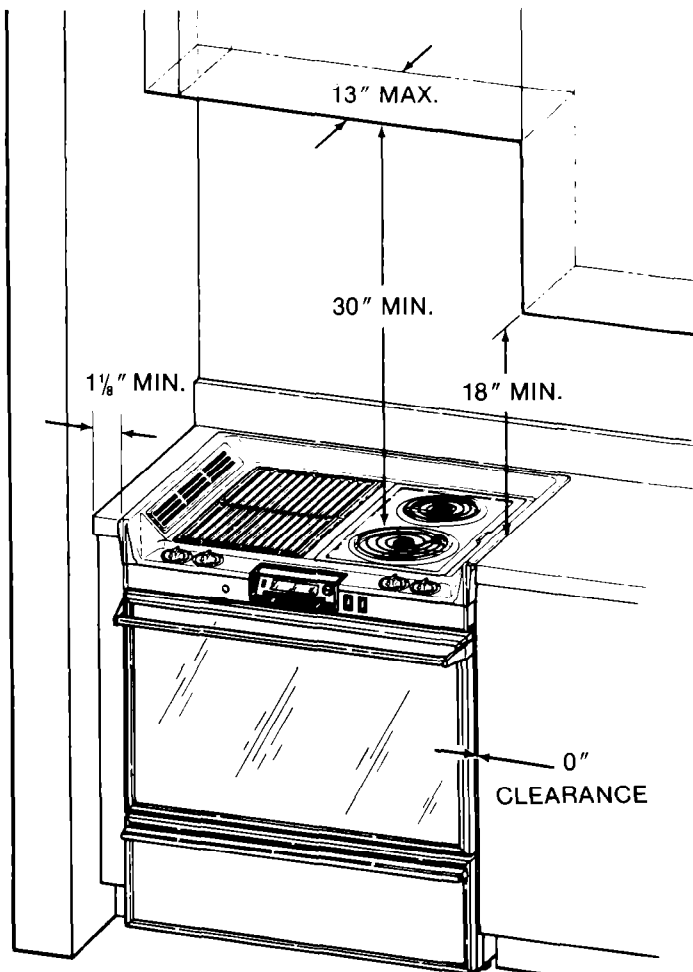

Fig. 1

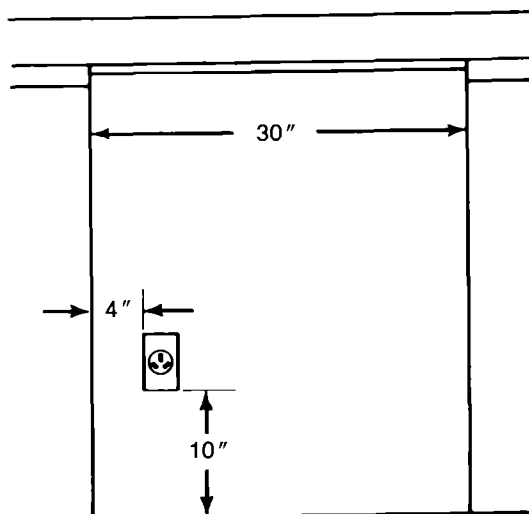

Fig. 2

4347927

Part No. 333239

STEP 2: PREPARING THE COUNTER

Your new Downdraft unit is designed to be installed in a section of built in cabinet. Allow 30" for the cutout width. The distance from the back of the wall to the front of the adjacent cabinet should be 24" and the counter top should have a depth of 25" (1" overhang).

Figure 3 shows required dimensions. To minimize chipping while cutting the countertop, mark the counter, apply masking tape, mark the cutout on top of the tape and then use a hand - or sabre saw to make the cut. If you are replacing a slide in range and have an existing 30" cutout with the countertop removed all the way to the wall, you can purchase backsplash kit no. 100-2112.

If the countertop is the raised bullnose type, file the countertop flat $\frac{3}{8}$ " from the sides of the cutout.

If the countertop is self edge, see Step 7.

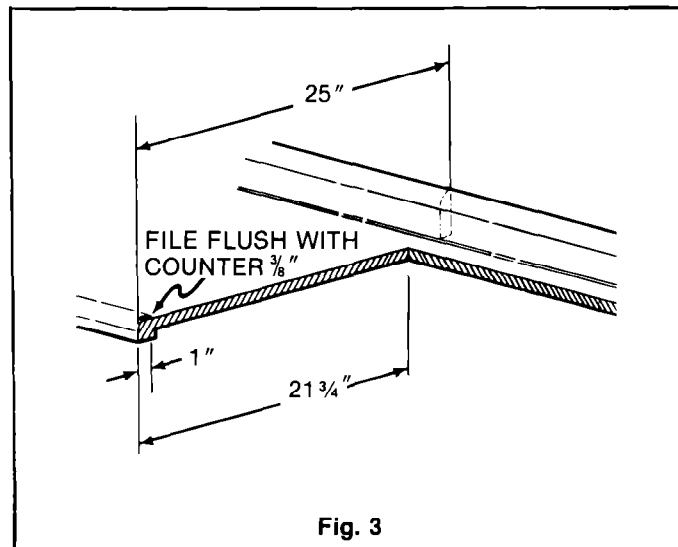

Fig. 3

STEP 3: LEVELING RANGE

For proper cooking and baking the range must be leveled.

- Use a $\frac{3}{8}$ " open end or adjustable wrench to equally back out the four leg levelers about $\frac{1}{2}$ ".
- Install the oven racks (see Owner's Manual for instructions).
- Place the range in the cutout, then put a spirit level or a glass measuring cup partially filled with water, on one of the oven racks. If using a spirit level, take two readings - with the level placed diagonally in one direction and then the other.
- Use the wrench to adjust leg levelers. You can reach the back levelers through the hinged door of the bottom compartment.

The bottom of the main top should be flush with the top of the counter.

- Remove unit from the cutout.

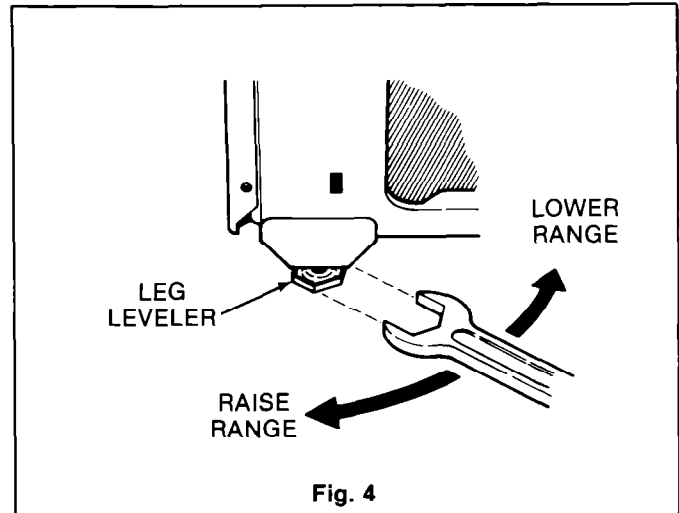

Fig. 4

STEP 4: INSTALL DUCTING

Determine how the duct will run (see Figure 6). See Figure 5 for recommended locations of duct openings. The duct opening can be moved in the shaded area.

Install the ducting from the cutout to the outside vent cap. Follow all requirements and restrictions in this section. To allow easy connection between the vent blower and the ducting make sure you bring the ducting into the cutout far enough.

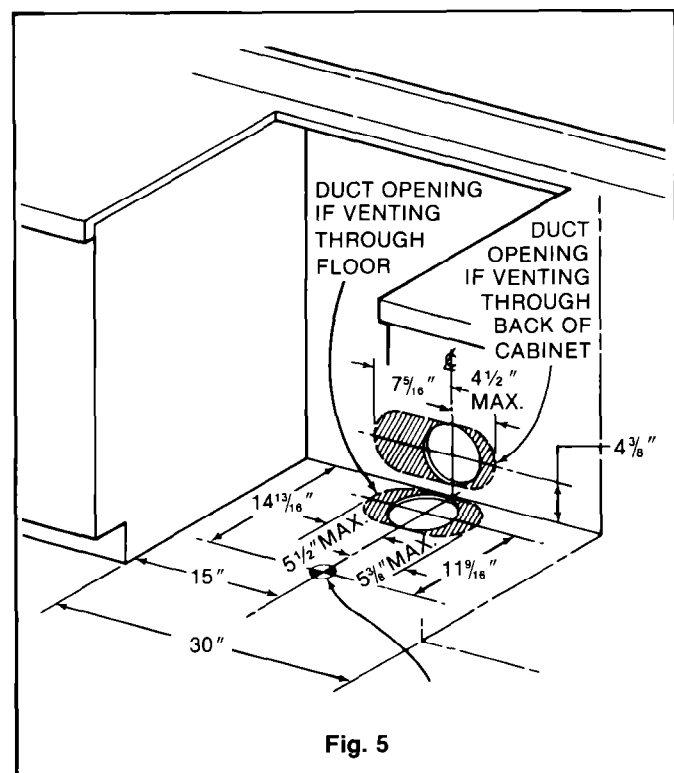

Fig. 5

STEP 5: MOUNTING THE BLOWER

Do not remove the large rubber seal on top of the blower. To help determine the position of the blower for different duct run directions, a template is packed in the carton. The template measures 30"x24" and fits the recommended cutout. Place the template on the floor, in the cutout, with the printed side up. On the template is shown the outline of the blower and corresponding locations of the screws that attach the blower to the floor.

After determining how your blower will be positioned according to the template, use a drill with a $\frac{3}{16}$ " bit and drill the 3 required holes in the floor with the template in place. Remove the template. Place the blower in the cutout, with the opening in the direction of the duct opening, and line the three tabs up with the predrilled holes. Use the screws provided to fasten the blower to the floor.

Connect the ducting to the transition on the blower.

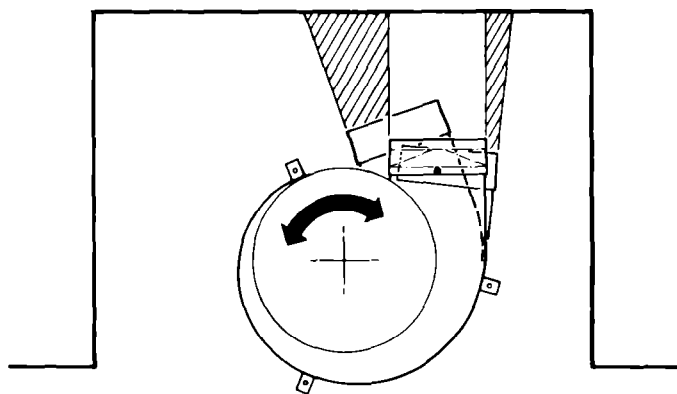

STEP 6: ELECTRICAL CONNECTIONS

The electrical power to the range supply line must be shut off while line connections are being made. Failure to do so could result in serious injury or death. Locate the junction block access cover on the range back and use a $\frac{1}{4}$ " hex socket nut driver or $\frac{1}{4}$ " socket wrench to remove the cover. Make connections to the range using a three wire cord or wires enclosed in a conduit. A clamp or strain relief must be used to secure the cord or conduit to the range. Replace the junction block access cover.

If desired, or if required by local codes, an approved four-wire flexible cord set may be used. This provides an ungrounded neutral. For installation in a mobile home, use of an approved four wire cord is required.

IMPORTANT: Electrical connections must be made before the range is placed in the cutout. Allow at least 4 ft. of cord.

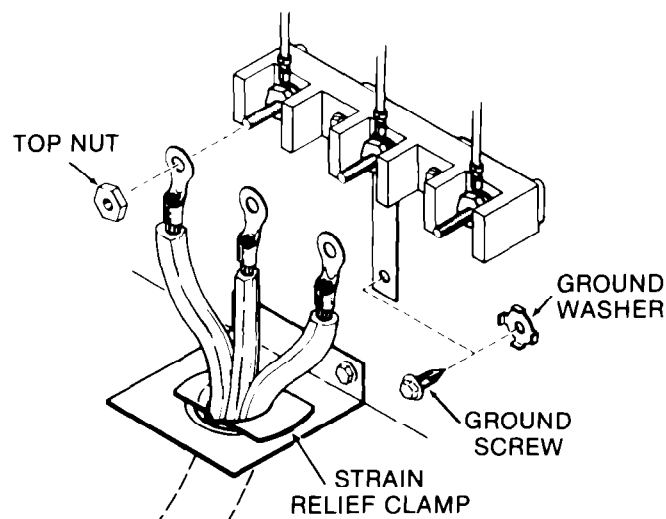

Fig. 8

ELECTRICAL REQUIREMENTS

Have the electrical wiring of your range done by a qualified electrician. After installation, have the electrician show you where your main disconnect is located.

Check with your local utility company which electrical codes apply in your area. Failure to wire your range according to governing codes could result in a hazardous condition. If there are no local codes, your range must be wired and fused to meet the requirements of the National Electrical Code, ANSI/NFPA No. 70-1984. You can get a copy by writing:

National Fire Protection
Batterymarch Park
Quincy, MA 02269

You must use a three wire, single phase AC 60 Hertz electrical system. Either a 208Y/120 Volt or 120/240 Volt system may be used. Do not use aluminum wire to connect your range to your household outlet.

In the absence of local codes, use No. 8 wire protected by a 40 Amp. fuse or circuit breaker for 208Y/120 Volt or 120/240 Volt systems.

3-WIRE CORD CONNECTION

Use a $\frac{3}{8}$ " hex socket nut driver or deep well socket wrench to remove the top nuts on the junction block studs and tighten the back nuts on the junction block studs securely. Install the strain relief in the hole in the strain relief bracket, then install the three wire cord through the strain relief clamp.

Using the nut driver, connect the outside leads to the outer terminals and the center lead to the center terminal. Tighten the nuts securely. From below the strain relief bracket, push the cord upward to relieve strain while tightening the clamp.





If local electrical codes require an ungrounded neutral, use a 4-wire cord or provide a separate ground wire. To do this remove the ground strap and fasten the center wire to the center terminal. Use the screw from the ground strap to fasten a No. 10 gauge copper ground wire to the range. Secure the other end of the wire to an approved ground.

Figuring the Duct Run

Only the 6" and 3 1/4" x 10" duct fittings shown in the chart below should be used to install your downdraft unit. Some pieces (noted in the chart) are available from your authorized Roper dealer. Others may be purchased at your local hardware or home supply store.

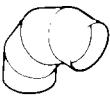
The maximum allowed duct run is 30 feet. Use the space provided in the chart to mark the equivalent feet of each

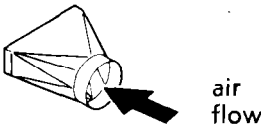
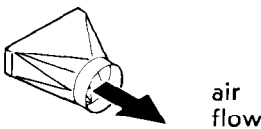
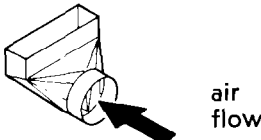
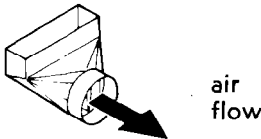
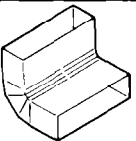
piece you use and add up your total duct run. Don't forget to add your number of feet of straight duct into the total. For instance, the first illustration at the top of the chart is a 6" diameter 90° elbow. It is equal to 5 feet of straight duct (second column in chart). If you use two of these elbows, you have used 10 feet of the 30 feet allowed for the entire duct run. Total your fittings and straight duct in the bottom righthand block.

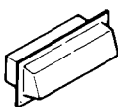
Duct Fittings		Equivalent Length	×	Number Used	=	Total Equivalent Length
6"-90° elbow		5 ft.				
6"-45° elbow		2.5 ft.				
6" to 3 1/4" x 10" transition Vent Kit No. 2V10ADE		1 ft.				
3 1/4" x 10" to 6" transition Vent Kit No. 2V10ADE		4.5 ft.				
6" to 3 1/4" x 10" 90° elbow Vent Kit No. 2V20ELE		9 ft.				
3 1/4" x 10" to 6" 90° elbow Vent Kit No. 2V20ELE		5 ft.				
3 1/4" x 10" 90° elbow		5 ft.				
3 1/4" x 10" 90° flat elbow		12 ft.				
6" Wall Cap Vent Kit No. 2V30CPE						
3 1/4" x 10" Wall Cap						
Add Feet of Straight Duct						
Total Duct Run (30 Feet Maximum)						

DUCTING (cont.)

DO

Use a minimum of 26 gauge galvanized, or 24 gauge aluminum metal ducting. Use heavier gauge if required by local codes.

Use PVC duct under a poured slab.

Use a short and straight duct run as possible. The shorter and straighter the run, the better the air flow. This is especially important on high altitude installations.

Use 6" dia. or 3 1/4 "x10" duct only. You may mix these sizes if you wish.

Use male-female duct connections in the direction of the air flow.

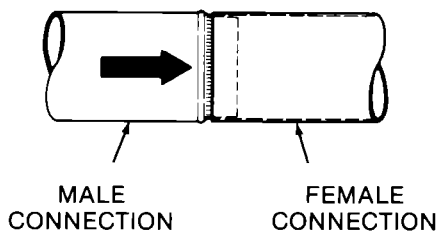

Secure all joints with a sheet metal screw and several wraps of duct tape to prevent smoke and odors from escaping. Use wire, if necessary to keep the duct from sagging.

Use a straight run a least 15" long between elbows and fittings.

Use one of the wall caps shown on next page.

DON'T

Don't exceed the maximum allowable duct run - 30 feet.

Don't exhaust more than one unit into the same duct system.

Don't exhaust air into a wall, ceiling crawl space or any other concealed space of the building. Grease buildup in those areas will create a fire hazard.

Don't use metal ducting (inc.- galvanized) under a poured slab.

Don't use more than three 90° elbows in a 6" dia. run.

Don't use more than two 90° elbows in a 3 1/4 x10" duct run.

Don't squeeze the duct to get through a tight space - any reduction in diameter will reduce proper air flow.

Don't use laundry type (4" dia.) wall caps or duct.

Don't use a roof or wall cap without a damper

SAMPLE DUCT RUNS

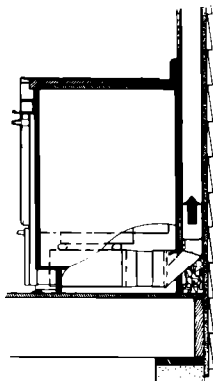

**Through Back
Wall, Out
Roofcap**

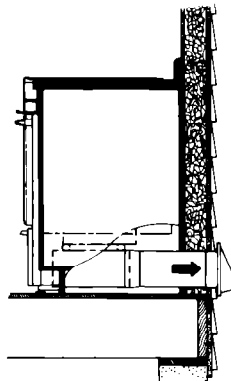

**Straight Out
Backwall**

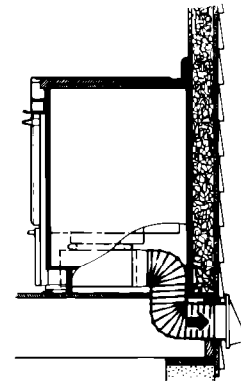

Through Floor

Fig. 6

ELECTRICAL CONNECTIONS (cont.) 4-WIRE CORD CONNECTION

Use a $\frac{3}{8}$ " hex socket nut driver or deep well socket wrench to remove the top nuts on the junction block studs. Remove the ground screw, then remove the ground strap from the junction block. Tighten the back nuts on the junction block studs securely.

Install the strain relief in the hole in the strain relief bracket. Install the 4 wire cord through the strain relief. Using the nut driver, connect the red and black leads to the outer terminals and the white lead to the center terminal. Tighten the nuts securely.

Use the previously removed ground screw to secure the green lead below the junction block. From the below the strain relief bracket, push the cord upward until the outer insulation is above the bracket, then tighten the clamp.

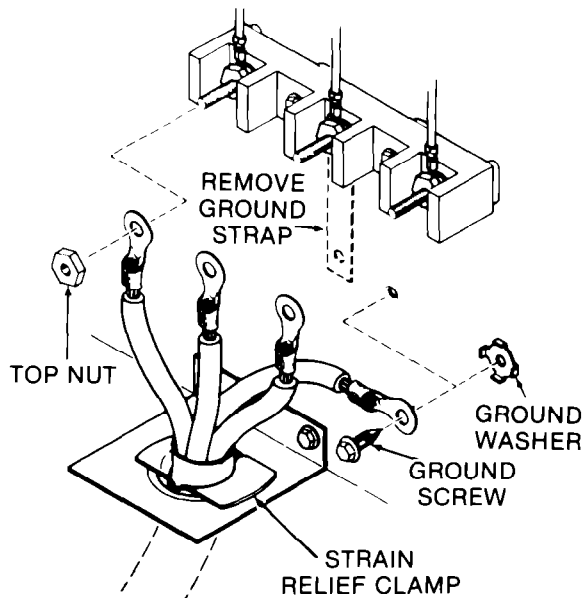

Fig. 9

STEP 7: POSITIONING RANGE

If your adjacent counters are self edge (counter), trim the endcaps with a hacksaw (Figure 10).

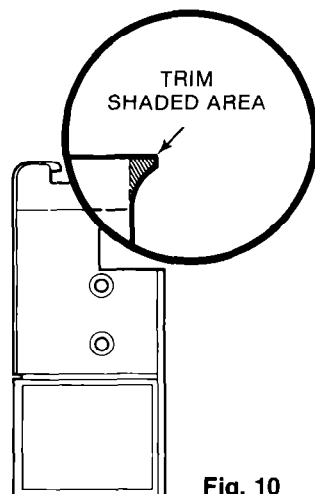

Fig. 10

Move the range directly in front of the cutout. Standing in front of the range, tilt it toward you (Figure 11). Maneuver the unit into the cutout, keeping the back raised in order to clear the blower.

Once the range is in place, open the lower compartment by grasping the handle and pulling the door down flat. There is a box (wire cover) in the front, at the top of the blower compartment. Connect the electrical plug of the blower to the mating connector on the left side of the box.

See your Use & Care Guide for instructions on inserting modules, downdraft vent filters and vent grills into the unit.



Never try to move the range without disconnecting the blower electrical connector in the lower compartment.

To check for proper seating of the range on the blower first visually inspect through the lower compartment. Make sure the rubber seal is not pinched or misplaced. Then turn the blower on with the on/off switch on the control panel and check for air leaks around the seal.

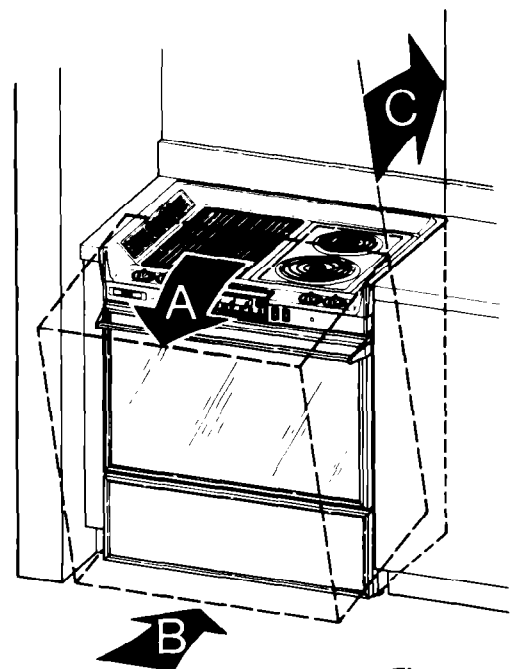

Fig. 11