Installation Instructions

Full Size Automatic Washer

Before beginning installation, carefully read these instructions. This will simplify the installation and ensure the washer is installed correctly and safely. Leave these instructions near the washer after installation for future reference.

NOTE: The electrical service to the washer must conform with local codes and ordinances and the latest edition of the National Electrical Code, ANSI/NFPA 70, or in Canada, CSA 22.1 Canadian Electrical Code Part 1.

Contents

SUBJECT	PAGE
Pre-Installation Requirements	2
Electrical Requirements	2
Grounding Requirements	2
Water Supply Requirements	2
Drain Requirements	2
Rough-In Dimensions	3
Location	3
Unpacking	3
Installation	3-4
Replacement Parts	4

PRE-INSTALLATION REQUIREMENTS

Tools Required for Installation:

1. 3/8 in. socket with ratchet.
2. Channel-lock adjustable pliers.
3. Carpenter's level.

ELECTRICAL REQUIREMENTS

CIRCUIT - Individual, properly polarized and grounded 15 amp. branch circuit fused with 15 amp. time delay fuse or circuit breaker.

POWER SUPPLY - 2 wire, with ground, 120 volt, single phase, 60 Hz, Alternating Current.

OUTLET RECEPTACLE - Properly grounded 3-prong receptacle to be located so the power supply cord is accessible when the washer is in an installed position.

GROUNDING REQUIREMENTS

⚠ WARNING Improper connection of the equipment grounding conductor can result in a risk of electrical shock. Check with a licensed electrician if you are in doubt as to whether the appliance is properly grounded.

1. The washer **MUST** be grounded. In the event of a malfunction or breakdown, grounding will reduce the risk of electrical shock by a path of least resistance for electrical current.
2. Since your washer is equipped with a power supply cord having an equipment-grounding conductor and a grounding plug, the plug **MUST** be plugged into an appropriate, copper wired receptacle that is properly installed and grounded in accordance with all local codes and ordinances or in the absence of local codes, with the National Electrical Codes, ANSI/NFPA 70 (latest edition). If in doubt, call a licensed electrician. **DO NOT** cut off or alter the grounding prong on the power supply cord. In situations where a two-slot receptacle is present, it is the owner's responsibility to have a licensed electrician replace it with a **properly grounded** three prong grounding type receptacle.

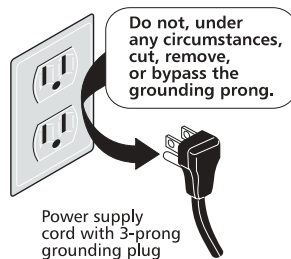

3. For added personal safety, connect a separate ground wire (No. 18 minimum) from a top panel hinge screw on the rear of the washer to a grounded cold water pipe. **DO NOT** ground to a gas supply pipe or hot water pipe.

4. Grounded cold water pipe **MUST** have metal continuity to electrical ground and **MUST** register no more than 25 ohms resistance. It **MUST** not be interrupted by plastic, rubber, or other electrical insulating connectors such as hoses, fittings, washers, gaskets (including water meter or pump). Any electrically insulated connector should be jumped with a length of No. 4 copper wire securely clamped to bare metal at both ends with a UL approved ground clamp.
5. If a grounded water pipe is not available, a ground rod **MUST** be used and register no more than 25 ohms resistance when in the ground. Drive the rod into the ground outside the dwelling and connect a grounding wire (12 AWG or heavier) between the grounding screw and the grounding rod. It may take more than one ground rod to not exceed 25 ohms resistance to ground.

WATER SUPPLY REQUIREMENTS

Hot and cold water faucets **MUST** be installed within 42 inches (107 cm) of your washer's water inlet. The faucets **MUST** be 3/4 inch (1.9 cm) garden hose type so inlet hoses can be connected. Water pressure **MUST** be between 10 and 120 pounds per square inch (maximum unbalance pressure, hot vs. cold, 10 psi.) Your water department can advise you of your water pressure. The hot water temperature should be about 140 degrees F (60 degrees C).

DRAIN REQUIREMENTS

1. Drain capable of eliminating 17 gallons (64.3 L) per minute.
2. A standpipe diameter of 1-1/4 in. (3.18 cm) minimum.
3. The standpipe height above the floor should be:
Minimum height: 33 in. (83.82 cm)
Maximum height: 96 in. (244 cm)

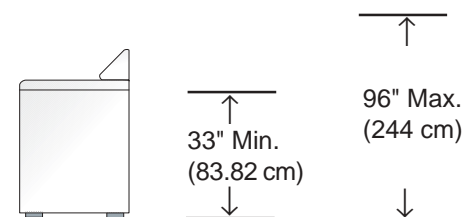

NOTE: For installations requiring a longer drain hose, have a qualified technician install a longer drain hose, P/N 134049201. For drain systems in the floor, install a syphon break kit, available from your local hardware store.

ROUGH-IN DIMENSIONS

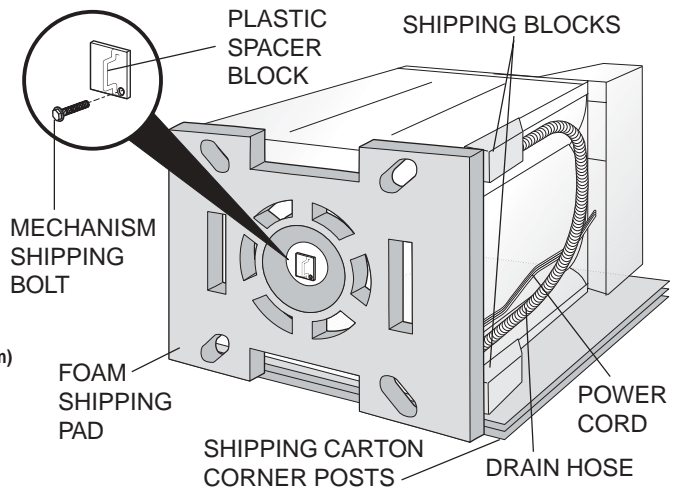
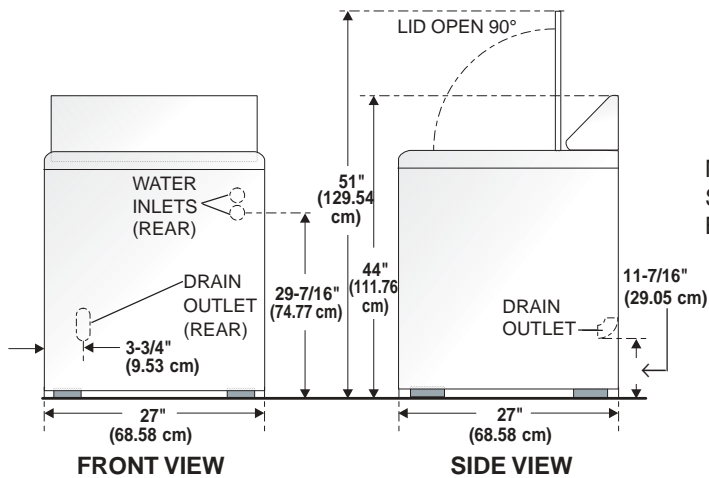

LOCATION OF YOUR WASHER

DO NOT INSTALL YOUR WASHER:

1. In an area exposed to dripping water or outside weather conditions. The ambient temperature should never be below 60 degrees F (15.6 degrees C) for proper washer operation.
2. In an area where it will come in contact with curtains or drapes.
3. In an area (garage or garage-type building) where gasoline or other flammables are kept or stored (including automobiles).
4. On carpet. Floor **MUST BE SOLID** with a maximum slope of 1 in. (2.54 cm). To ensure vibration or movement does not occur, **REINFORCEMENT** of the floor may be necessary.

IMPORTANT MINIMUM INSTALLATION CLEARANCES

When installed in alcove: Sides = 0" (0 cm),
Rear = 0" (0 cm), Top = 20" (50.8 cm).

When installed in closet: Sides = 0" (0 cm),
Rear = 0" (0 cm), Top = 20" (50.8 cm), Front = 1"
(2.54 cm).

Closet door ventilation required: 2 louvered openings
each 60 square inches (387 cm²) — 3 inches (7.6 cm)
from bottom and top of door.

UNPACKING

1. Using the four shipping carton corner posts (two on each side), carefully lay the washer on its left side and remove foam shipping base.
2. Using a ratchet with 3/8" socket, remove the mechanism shipping bolt and plastic spacer block from the center of the base.

NOTE: If the washer is to be transported at a later date, the tub blocking pad, shipping bolt, and plastic spacer block should be retained.

3. Return the washer to an upright position.
4. Remove the tape holding the lid shut and open the lid.
5. Remove the foam tub blocking pad.
6. Remove the inlet hoses and enclosure package from the tub.
7. From the back of the washer, remove only the WIRE shipping clips that secure the drain hose to the left side of the washer backsheet. **DO NOT REMOVE THE PLASTIC CLAMPS** on the right side of the washer. These clamps form a standpipe to prevent water siphoning.
8. Carefully move the washer to within 4 feet of the final location for the start of the installation.

INSTALLATION

1. Run some water from the hot and cold faucets to flush the water lines and remove particles that might clog up the water valve screens.
2. Remove the inlet hoses and rubber washers from the plastic bag and install the rubber washers in each end of the inlet hoses.
3. Carefully connect the inlet hose marked "HOT" to the bottom outlet of the water valve. Tighten by hand, then tighten another 2/3 turn with pliers. Carefully connect the other inlet hose to the top outlet of the water valve. Tighten by hand, then tighten another 2/3 turn with pliers.



⚠ CAUTION DO NOT CROSS THREAD OR OVERTIGHTEN THESE CONNECTIONS.

- Determine which water faucet is the **HOT** water faucet and carefully connect the bottom inlet hose to the **HOT** water faucet, tighten by hand, then tighten another 2/3 turn with pliers. Carefully connect the top inlet hose to the **COLD** water faucet, tighten by hand, then tighten another 2/3 turn with pliers.

⚠ CAUTION DO NOT CROSS THREAD OR OVERTIGHTEN THESE CONNECTIONS.

Turn the water on and check for leaks at both connections.

- Carefully move the washer to its final location.
- To ensure the washer is level and solid on all four legs, open the lid, grasp the top panel and tilt the washer forward so the rear legs are off the ground. Gently set the washer back down to allow the rear legs to self adjust. Place a level on top of the washer. Check it side to side, then front to back. Screw the front leveling legs up or down to ensure the washer is resting solid on all four legs (no rocking of the washer should exist).

NOTE: Keep the leg extension at a minimum to prevent excessive vibration. The farther out the legs are extended, the more the washer will vibrate.

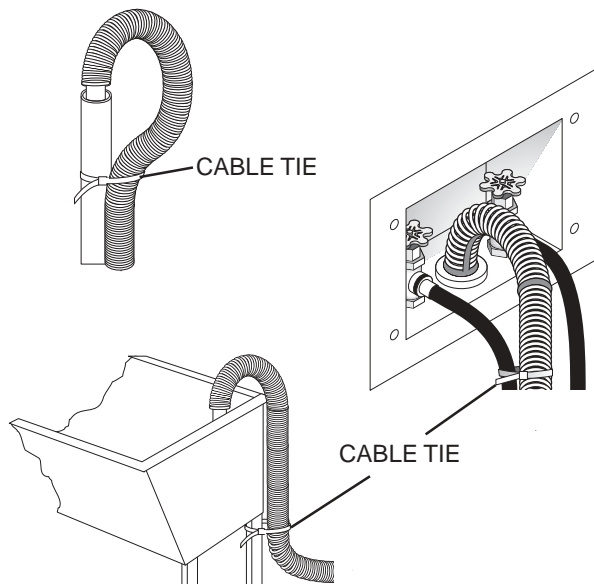

- Form a "U" shape on the end of the drain hose with the hose pointed toward the drain. Place the formed end in a laundry tub or a standpipe and secure with a cable tie provided in the enclosure package.

NOTE: The standpipe inside diameter must be 1-1/4" (3.18 cm) minimum. There must be an air gap around the drain hose in the standpipe. A snug hose fit can cause a siphoning action.

- Plug the power cord into a grounded outlet.

NOTE: Check to ensure the power is off at a circuit breaker/fuse box before plugging the power cord into an outlet.

- Turn on the power at a circuit breaker/fuse box.
- Read the Operating Instructions and Owner's Guide provided with the washer. They contain valuable and helpful information that will save you time and money.
- Run the washer through a complete cycle. Check for water leaks and proper operation.
- If your washer does not operate, please review the "Avoid Service Checklist" located in your Owner's Guide before calling for service.
- Place these instructions in a location near the washer for future reference.

NOTE: A wiring diagram is located inside the washer console.

REPLACEMENT PARTS

UNITED STATES

If replacement parts are needed for your washer, contact the source where you purchased your washer, call 1-800-944-9044 or visit our website, www.frigidaire.com, for the Frigidaire Company Authorized Parts Distributor nearest you.

CANADA

If replacement parts are needed for your washer, contact your local dealer/retailer or call (905) 565-9200 for the authorized Frigidaire Parts and Service depot nearest you.

⚠ WARNING Destroy the carton and plastic bags after the washer is unpacked. Children might use them for play. Cartons covered with rugs, bedspreads, or plastic sheets can become airtight chambers causing suffocation. Place all materials in a garbage container or make materials inaccessible to children.

⚠ WARNING The instructions in this manual and all other literature included with this washer are not meant to cover every possible condition and situation that may occur. Good safe practice and caution **MUST** be applied when installing, operating and maintaining any appliance.

Maximum benefits and enjoyment are achieved when all the Safety and Operating instructions are understood and practiced as a routine with your laundering tasks.