

KitchenAid® Undercounter Dishwasher

PRODUCT MODEL SERIES

KUDC01IM	KUDK01TK	KUDP01TJ
KUDI01DL	KUDL01IL	KUDR01TJ
KUDI01FK	KUDL01TK	KUDS01DJ
KUDI01FL	KUDM01FK	KUDS01DL
KUDI01IL	KUDM01TJ	KUDS01FL
KUDI01TJ	KUDP01DL	KUDS01FL
KUDJ01TJ	KUDP01FL	KUDS01IJ
KUDK01IL	KUDP01IL	KUDS01IL

Electrical: 120-volt, 60-Hz, AC-only, 15- or 20-amp. electrical supply. Use copper wire only. A time-delay fuse or circuit breaker and separate circuit is recommended.

Water: A hot water line with 20-120 psi (138-862 kPa) water pressure. Water temperature must be minimum 120°F (49°C) at dishwasher. Use 3/8" O.D. copper tubing with compression fitting or flexible stainless steel braided fill line (1/2" minimum plastic tubing is optional but not recommended). Use a 90° elbow with 3/8" N.P.T. external pipe threads on one end to connect to water inlet valve. Do not solder within 6" (15.2 cm) from water inlet valve.

Drain: Use the new drain hose supplied with your dishwasher. If this is not suitable, use a new drain hose with a maximum length of 12 feet (3.7 m) that meets all current AHAM/IAPMO test standards, is resistant to heat and detergent, and fits the drain connector of the dishwasher. Must have a high drain loop 20 inches (50.8 cm) above the subfloor or floor. Connect drain hose to waste tee or disposer inlet above drain trap in house plumbing and 20 inches (50.8 cm) minimum above the floor. An air gap must be used if the drain hose is connected to house plumbing lower than 20 inches (50.8 cm) above subfloor or floor. Use 1/2" minimum I.D. drain line fittings.

Corner installation: Allow 2" (5.1 cm) minimum between corner wall and dishwasher opening.

Grommet is required for electrical cable or power supply cord hole cut in a metal cabinet.

Do NOT install dishwasher over carpeted floor.

Unit accepts custom door panels.

OVERALL DIMENSIONS

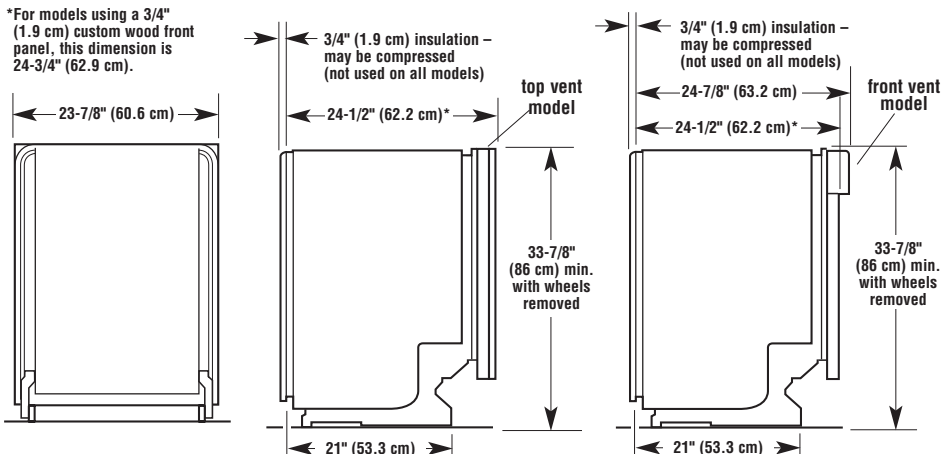

CABINET OPENING DIMENSIONS

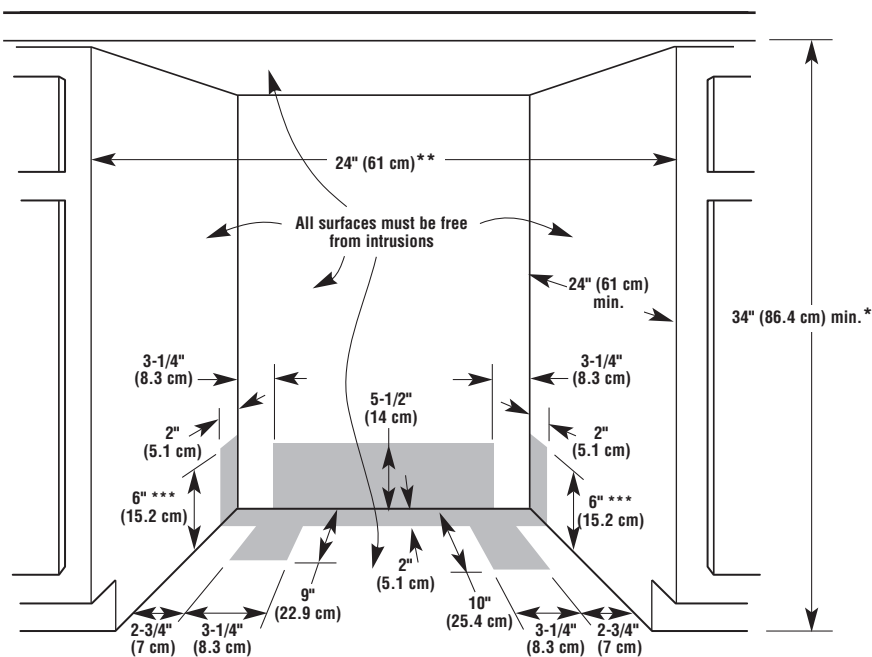

*Measured from the lowest point on the underside of countertop.

May be reduced to 33-7/8" (86 cm) by removing wheels from dishwasher.

**Minimum, measured from narrowest point of opening.

***May be increased to 6-5/8" (16.6 cm) if height of opening is 34-1/2" (87.6 cm) at its lowest point.

CUSTOM FRONT PANEL DIMENSIONS

