

# SERVICE DATA SHEET

# 318127015 (0306) Rev. A

Dual Fuel (Gas Cooktop - Electric Oven) Slide-in Range  
with ES300 Electronic Oven Control and Speed Bake Feature

## NOTICE

This service data sheet is intended for use by persons having electrical and mechanical training and a level of knowledge of these subjects generally considered acceptable in the appliance repair trade. **The manufacturer cannot be responsible, nor assume any liability, for injury or damage of any kind arising from the use of this data sheet.**

## SAFE SERVICING PRACTICES

To avoid the possibility of personal injury and/or property damage, it is important that safe servicing practices be observed. The following are examples, but without limitation, of such practices.

1. Do not attempt a product repair if you have any doubts as to your ability to complete it in a safe and satisfactory manner.
2. Before servicing or moving an appliance, remove power cord from electric outlet, trip circuit breaker to Off, or remove fuse and turn off gas supply.
3. Never interfere with the proper installation of any safety device.
4. USE ONLY REPLACEMENT PARTS CATALOGED FOR THIS APPLIANCE. SUBSTITUTIONS MAY DEFEAT COMPLIANCE WITH SAFETY STANDARDS SET FOR HOME APPLIANCES.
5. GROUNDING: The standard color coding for safety ground wires is GREEN OR GREEN WITH YELLOW STRIPES. Ground leads are not to be used as current carrying conductors. IT IS EXTREMELY IMPORTANT THAT THE SERVICE TECHNICIAN REESTABLISH ALL SAFETY GROUNDS PRIOR TO COMPLETION OF SERVICE. FAILURE TO DO SO WILL CREATE A POTENTIAL HAZARD.
6. Prior to returning the product to service, ensure that:
  - All electric connections are correct and secure.
  - All electrical leads are properly dressed and secured away from sharp edges, high-temperature components, and moving parts.
  - All non-insulated electrical terminals, connectors, heaters, etc. are adequately spaced away from all metal parts and panels.
  - All safety grounds (both internal and external) are correctly and securely reassembled.
  - All panels are properly and securely reassembled.

## ES300 ELECTRONIC OVEN CONTROL

The ES300 electronic oven control is almost identical to the current control with a few exceptions.

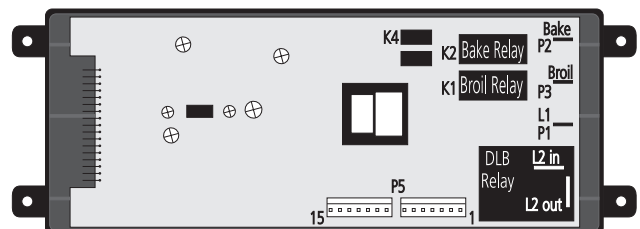
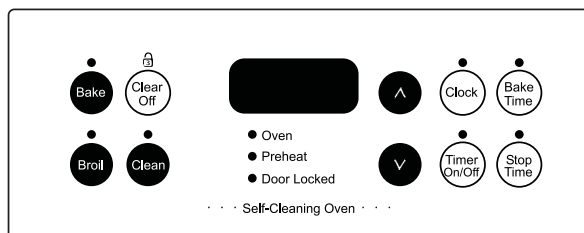

**Note:** The ES300's are not field repairable. Only temperature settings can be changed. See Electronic Oven Control Guide (section recalibrating your oven temperature).

**Note:** Depending on model, the size and shape of touch pads may vary (for example round instead of elliptical).

## NORMAL BAKE

During a normal bake mode, the control preheats the oven with the bake element. When the desired temperature is reached, the control adds top heat by cycling the broil element on for 6 to 9 seconds per minute. The bake element is on for the remaining time of the minute. Both elements use full power when they are on but they are never on at the same time.

## CLEAN

During a cleaning process, the oven uses the bake element. When this mode is called, the door locks right after start button is pushed.

## FIRST RISE

It is normal to see a temperature overshoot in the first rise of all modes when you monitor the temperature.

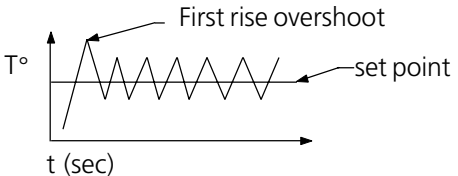

## ELECTRONIC OVEN CONTROL

<b>ELECTRONIC OVEN CONTROL FAULT CODE DESCRIPTIONS AND RTD SCALE</b>		
<p><b>Note:</b> Only three fault codes are displayed by this control "F1", "F3", and "F9". Generally speaking "F1" implies a control failure, "F3" an oven probe problem, and "F9" a latch motor problem. In all occurrences the alarm is accompanied by a display of "F1"</p>		
Fault Code	Likely Failure Condition/Cause	Suggested Corrective Action
<b>F1</b>	<ol style="list-style-type: none"> <li>1. Shorted keypad.</li> <li>2. Control's internal checksum may have become corrupted.</li> <li>3. Control has sensed a potential runaway oven condition. Control may have shorted relay, RTD sensor probe may have gone bad.</li> </ol>	<ol style="list-style-type: none"> <li>1. Replace EOC.</li> <li>2. Disconnect power, wait 30 seconds and reapply power. If fault returns upon power-up, replace EOC.</li> <li>3. Check RTD sensor probe and replace if necessary. If oven is overheating, disconnect power. If oven continues to overheat when the power is reapplied, replace EOC. Severe overheating may require the entire oven to be replaced, should damage be extensive.</li> </ol>
<b>F3</b>	<ol style="list-style-type: none"> <li>1. Open RTD sensor probe/ wiring problem. Note: EOC may initially display an "F1", thinking a runaway condition exists.</li> <li>2. Shorted RTD sensor probe / wiring problem. Note: "F3" is displayed when oven is in active mode or an attempt to enter an active mode is made.</li> </ol>	<ol style="list-style-type: none"> <li>1. Check wiring in probe circuit for possible open condition. Check RTD resistance at room temperature (compare to probe resistance chart). If resistance does not match the chart, replace the RTD sensor probe.</li> <li>2. Check wiring in probe circuit for possible short condition. Check RTD resistance at room temperature (compare to probe resistance chart). If resistance does not match the chart, replace the RTD sensor probe.</li> </ol>
<b>F9</b>	<ol style="list-style-type: none"> <li>1. Door motor failure/ jammed. Latch motor switch failure.</li> <li>2. Control software failure, or component failure (relay stuck).</li> <li>3. Safety thermostat opened, or cooling fan stalled.</li> <li>4. Wiring Problem.</li> </ol>	<ol style="list-style-type: none"> <li>1. Press CLEAR key.</li> <li>2. If CLEAR key does not eliminate problem, turn off power for 30 seconds, then turn on power.</li> <li>3. Check wiring of Lock Motor, and Lock Switch A and Door Switch circuits. Look for stalled cooling fan, broken safety thermostat, shorts or opens.</li> <li>4. Unplug P4, apply power (L1) directly to the Lock Motor, if the motor does not rotate, replace Lock Motor Assembly. Plug P4.</li> <li>5. Check Lock Switch A for proper operation (do they open and close, check with ohmmeter). The Lock Motor may be powered as in above step to open and close Lock Switch. If the Lock Switch is defective, replace Motor Lock Assembly.</li> <li>6. If all above steps fail to correct situation, replace control.</li> </ol>

RTD SCALE		
Temp. °F	Temp. °C	Resistance (ohms)
32 ± 1.9	0.0 ± 1.1	1000 ± 4.0
75 ± 2.5	23.9 ± 1.4	1091 ± 5.3
250 ± 4.4	121.1 ± 2.4	1453 ± 8.9
350 ± 5.4	176.7 ± 3.0	1654 ± 10.8
450 ± 6.9	232.2 ± 3.8	1852 ± 13.5
550 ± 8.2	287.8 ± 4.6	2047 ± 15.8
650 ± 9.6	343.3 ± 5.3	2237 ± 18.5
900 ± 13.6	482.2 ± 7.6	2697 ± 24.4

ELECTRICAL RATING	
Kw Rating 240/208 V	See nameplate
Broil Element Wattage	2750W/2065W
Warmer Drawer Element	450W/120V
Bake Element Wattage	3000W/2253W

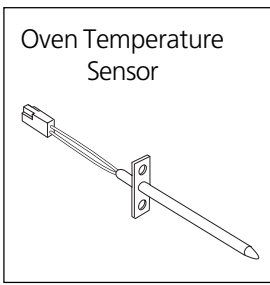

CIRCUIT ANALYSIS MATRIX						
	Bake P1 & P2	Broil P1 & P3	MDL P5-6 & N	Lock Motor Switch A	Cooling Fan	
					Top Coil	Top Ceran
Bake	X	X*				X
Broil		X				X
Clean	X			X	X	X
Unlocked						
Locking			X			
Locked				X		
Unlocking			X			
Speed Bake	X					X

\* Denotes broil element alternate with bake element.

### DOOR LOCK MECHANISM

The appliance is equipped with an electronic oven control and has an auto locking door latch feature. When the self clean cycle is programmed, the door is locked by a motor operated latch system. The interior of oven doesn't need to heat up to 500°F/260°C before the door locks. However, until the temperature inside oven reaches 500°F/260°C, the self-clean program can be canceled and door will unlock immediately. After oven reaches temperatures over 500°F/260°C, the door will not unlock until temperature drops below 500°F/260°C.

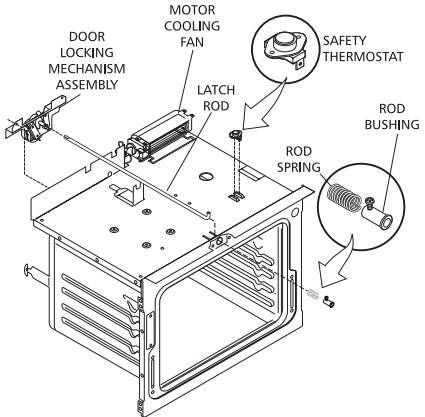
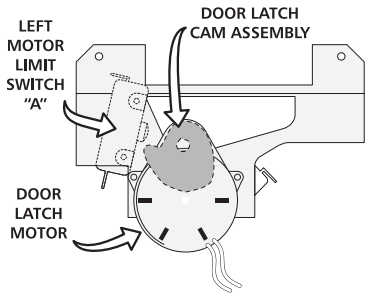

## OVEN DOOR REMOVAL AND REPLACEMENT

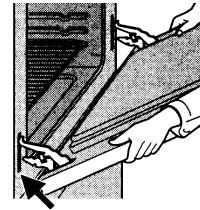
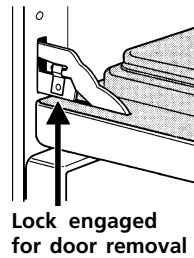
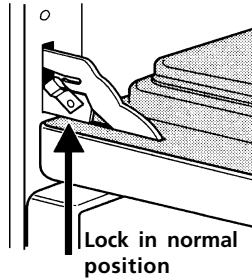

HINGE SLOT Door removed from the range

### To Remove the Oven Door:

1. Disconnect range from electrical supply
2. Open the door to the fully opened position.
3. Pull up the lock located on both hinge supports and engage it in the hinge levers. You may have to apply a little downward pressure on the door to pull the locks fully over the hooks.
4. Grab the door by the sides, pull the bottom of the door up and toward you to disengage the hinge supports. Keep pulling the bottom of the door toward you while rotating the top of the door toward the range to completely disengage the hinge levers.

### To Replace the Oven Door:

1. Grab the door by the sides; place the hinge supports in the hinge slots. Open the door to the fully opened position.
2. Disengage the lock from the hinge levers on both sides.  
**Note:** Make sure the hinge supports are fully engaged before unlocking the hinge levers.
3. Close the oven door.

**CAUTION** The door is heavy. After removing door, lay it flat on the floor with the inside of the door facing down.

## GAS COOKTOP REMOVAL

1. Shut off gas to range.
2. Disconnect power.
3. Remove gas supply line at the regulator. If necessary, move range out of the cabinet opening.
4. Remove grates and burner caps. Inspect burners.
5. Remove screws securing burner skirts. Inspect electrode, cleanliness, etc.  
**Note:** The electrode can not be removed from orifice holder assembly.
6. Remove knobs.
7. Remove flange nut.
9. Remove Control Panel.
9. Remove switch mounting plate screws.
10. Remove 2 screws from front shield on each side panels.
11. Remove 5 screws from front shield and 4 screws from vent trim to be able to remove console.
12. Remove machine screw on manifold side range securing manifold to cooktop.
13. Remove cooktop assembly from unit.
14. Remove screws all around mounting plate element located under cooktop assembly.
15. Remove glass assembly from burner box.
16. To reassemble cooktop, reverse procedures.

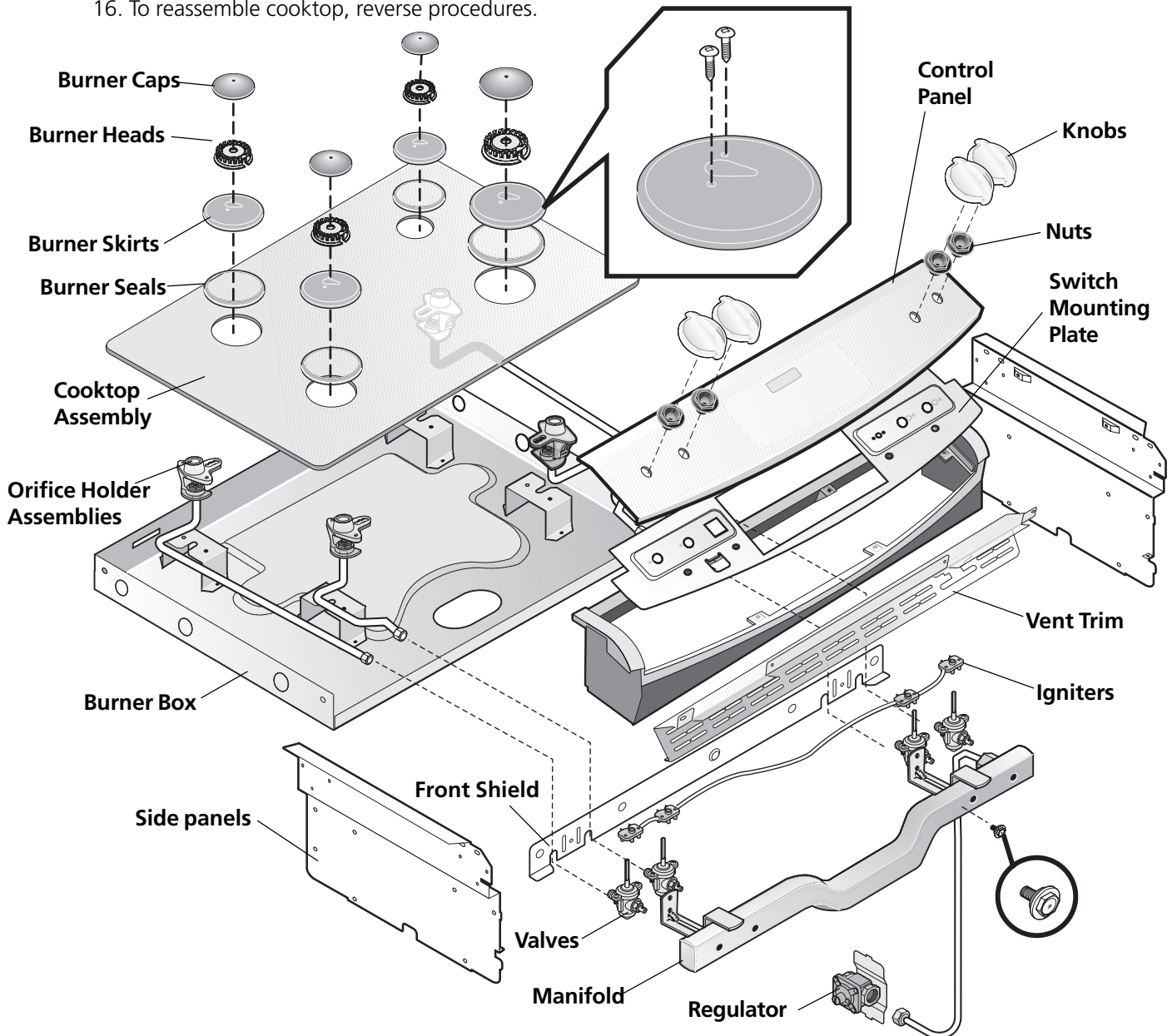

# WARMER DRAWER (SOME MODELS)

## COMPLETE CIRCUIT

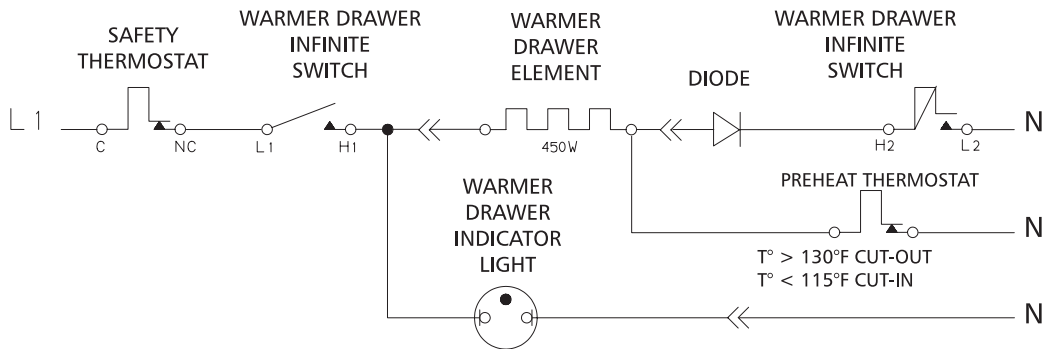

When the Warm and Serve Drawer is first turned on, a "Preheat" circuit is established to provide full power (120 volts) through the lock switch, L1 to H1 of the warmer switch, the warmer element and the preheat thermostat.

## PREHEAT

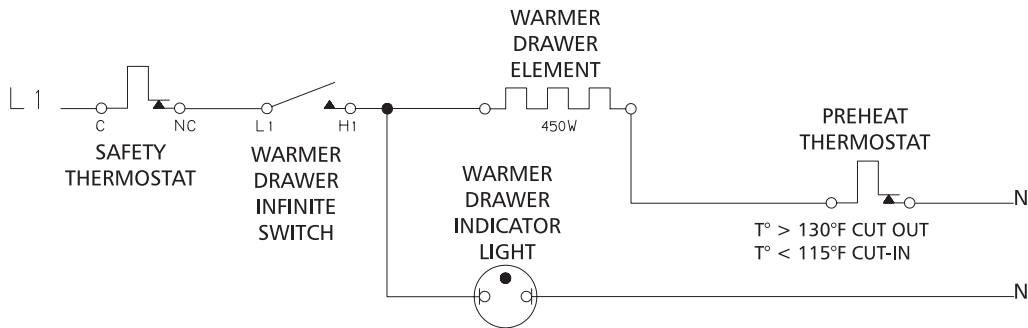

When the temperature at the preheat thermostat reaches 130°F the thermostat opens. This forces the current to flow through the parallel circuit which contains the diode. The diode allows only half power (every other pulse of electricity or pulsating DC) to flow through the element, resulting in lower heat output by the element. The infinite heat control switch will cycle as necessary to maintain the temperature in the drawer as indicated by the control switch setting. If the control is placed on a lower setting, it is possible for the temperature in the drawer to drop enough to allow the preheat thermostat to close again which will allow the element to reenter the "Preheat" mode at full power.

## AFTER CUT-OUT

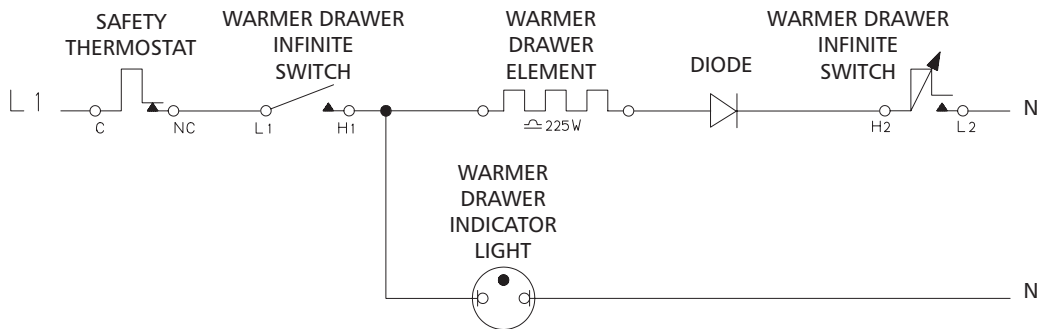

An indicator lamp wired in parallel with the element is illuminated whenever the control switch is turned on.



