

# Installation Instructions

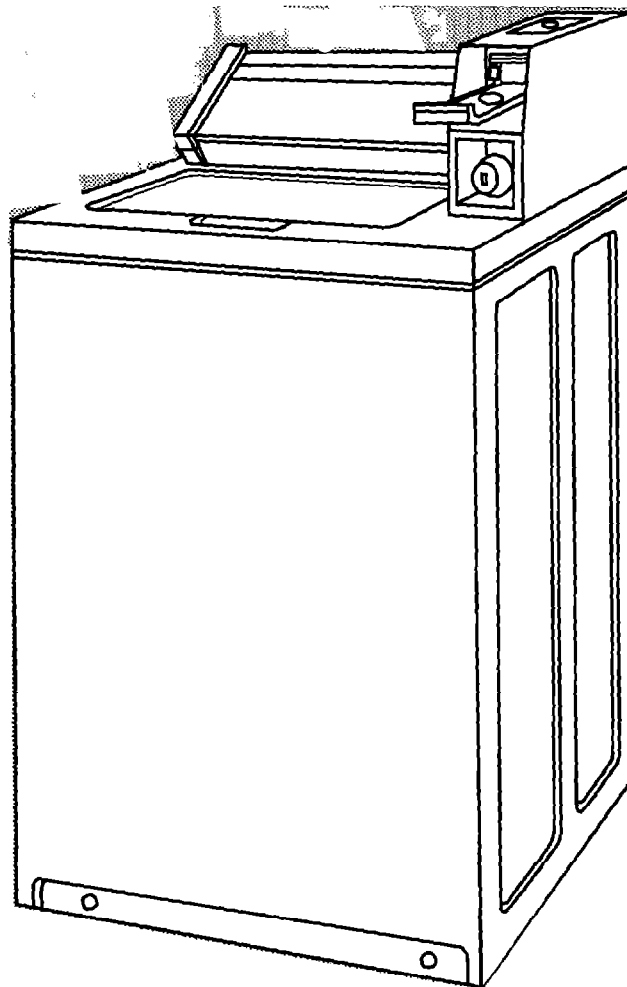

**IMPORTANT:**  
Read and save  
these instructions

**IMPORTANT:**

**Installer:** Leave Installation Instructions with the owner.

**Owner:** Keep Installation Instructions for future reference.

**Save** Installation Instructions for local electrical inspector's use.

Part No. 3360616 Rev. B

2-98

**COMMERCIAL  
ELECTRONIC WASHER**

**120-volt, 60-Hz Models**

  
**Whirlpool**<sup>®</sup>  
COMMERCIAL  
LAUNDRY  
PRODUCTS

## Before you start...

**Your safety and the safety of others is very important.**

We have provided many important safety messages in this manual and on your appliance. Always read and obey all safety messages.



This is the safety alert symbol. This symbol alerts you to hazards that can kill or hurt you and others. All safety messages will be preceded by the safety alert symbol and the word "DANGER" or "WARNING". These words mean:

**⚠ DANGER**

**You will be killed or seriously injured if you don't follow instructions.**

**⚠ WARNING**

**You can be killed or seriously injured if you don't follow instructions.**

**All safety messages will identify the hazard, tell you how to reduce the chance of injury, and tell you what can happen if the instructions are not followed.**

If a longer drain hose is needed, drain hose (Part No. 388423) and hose extension kit (Part No. 285442) are available from authorized parts centers. If drain hose must be shortened, use kit (Part No. 285442).

**To access additional functions in the electronic control, a hand-held terminal and operating guide are available from:**

Set-O-Matic, Inc.  
Farmingdale, N.Y. 11735  
1-800-645-3441

Check location where washer will be installed. Proper installation is your responsibility. Make sure you have everything necessary for correct installation.

**Do Not store or operate washer below 32°F (some water may remain in washer).**

**See Use & Care Guide for "Winterizing" information.**

Single washer installations require 12-inch minimum risers to provide an air cushion and prevent noise and damage to valves.

**Grounded electrical outlet** is required. See Electrical requirements.

**Hot and cold water faucets:** Must be within 4 feet of the back of the washer and provide water pressure 10-100 PSI. A pressure reduction valve should be used in the supply line where inlet pressure entering the building exceeds 100 PSI to prevent damage to the washer mixing valve.

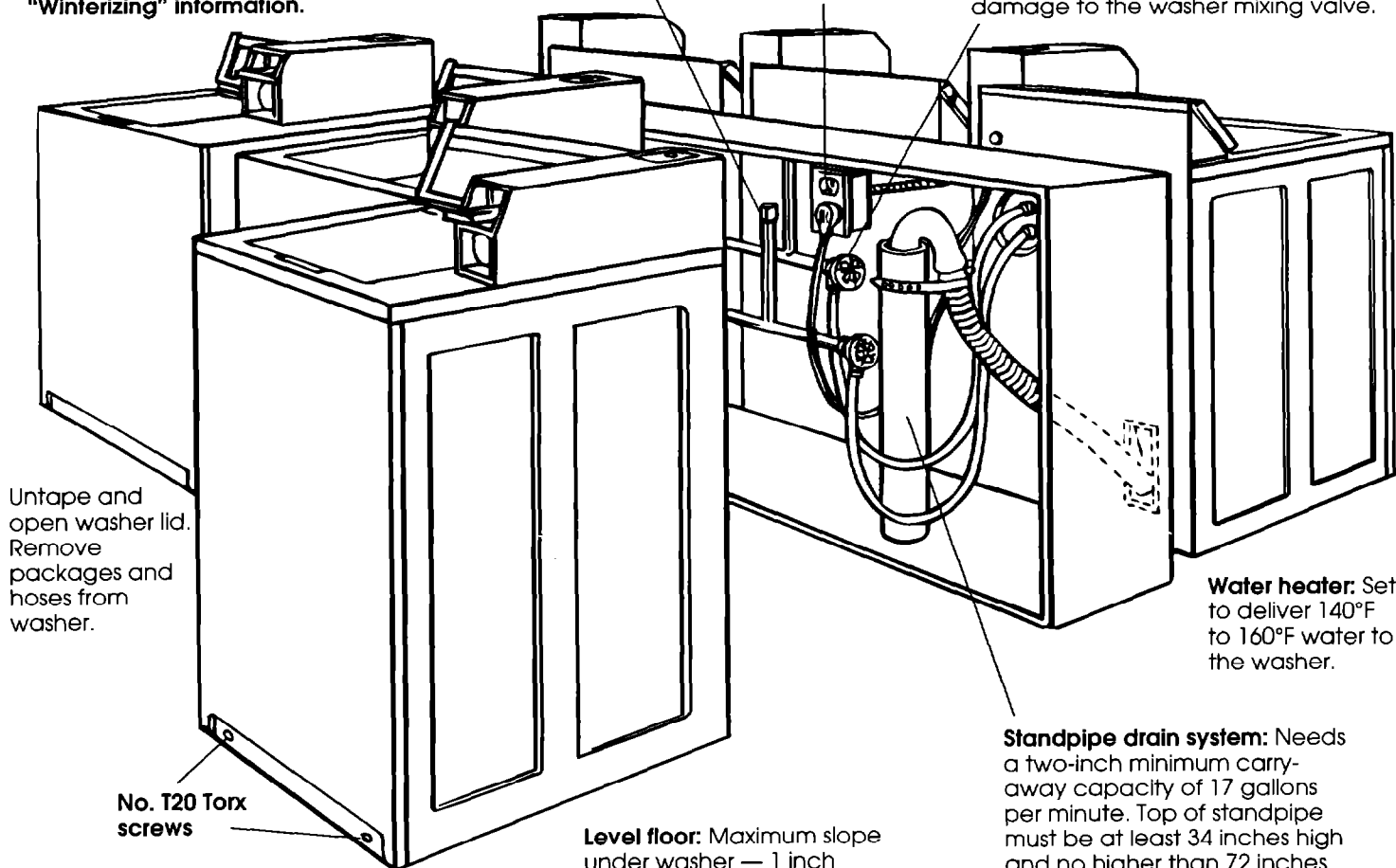

Untape and open washer lid. Remove packages and hoses from washer.

No. T20 Torx screws

Level floor: Maximum slope under washer — 1 inch

Water heater: Set to deliver 140°F to 160°F water to the washer.

Standpipe drain system: Needs a two-inch minimum carry-away capacity of 17 gallons per minute. Top of standpipe must be at least 34 inches high and no higher than 72 inches from bottom of washer.

On coin-operated washers, front access to the pump area is available by removing the two, No. T20 Torx screws and then removing the front panel.

**A floor drain** should be provided under the bulkhead. Prefabricated bulkheads with electrical outlets, water supply lines and drain facilities should be used only where local codes permit.

**Support:** Floor must be sturdy enough to support loaded washer weight of 315 pounds.

**Important: Observe all governing codes and ordinances.**

## Tools needed for installation:

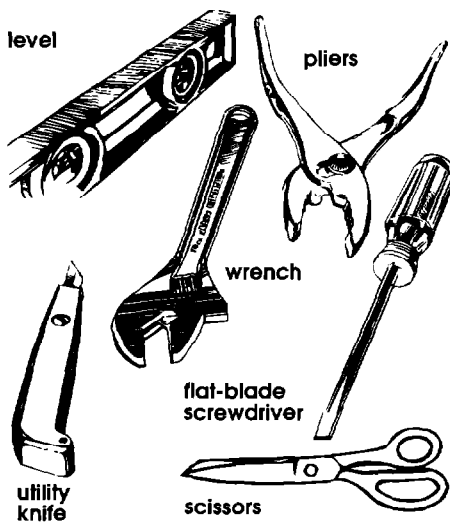

## Parts supplied for installation:

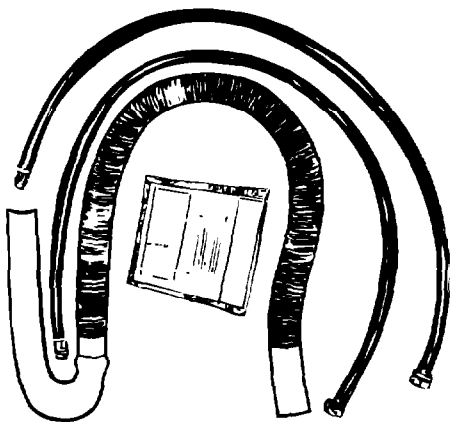

Remove parts from packages. Check that all parts were included.

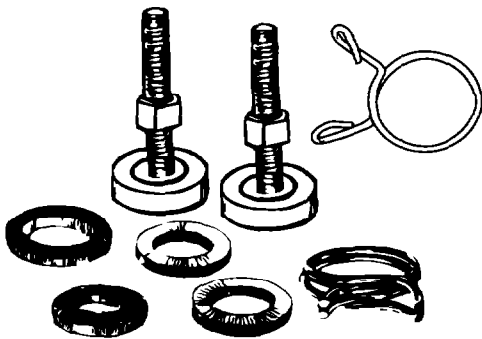

- 1 hose clamp
- 2 inlet hoses
- 4 flat water hose washers
- 2 front-leveling legs with nuts
- 1 drain hose
- 1 small clamp

## Electrical requirements

### ⚠ WARNING



**Electrical Shock Hazard**  
**Plug into a grounded 3-prong outlet.**  
**Do not remove ground prong.**  
**Do not use an adapter.**  
**Do not use an extension cord.**  
**Failure to follow these instructions can result in death, fire, or electrical shock.**

If codes permit and a separate ground wire is used, it is recommended that a qualified electrician determine that the ground path is adequate.

**Do Not ground to a gas pipe.**

**Check with a qualified electrician if you are not sure the appliance is properly grounded.**

**Do Not have a fuse in the neutral or ground circuit.**

A 120-volt, 60-Hz, AC-only, 15- or 20-ampere fused electrical supply is required. (Time-delay fuse or circuit breaker is recommended.) It is recommended that a separate circuit serving only this appliance be provided.

### Recommended ground method

For your personal safety, this appliance must be grounded. This appliance is equipped with a power supply cord having 3-prong ground plug. To minimize possible shock hazard, the cord must be plugged into a mating 3-prong ground-type wall receptacle, grounded in accordance with Canadian Electrical Codes and all local codes and ordinances. See Figure 1. If a mating wall receptacle is not available, it is the personal responsibility and obligation of the customer to have a properly grounded 3-prong wall receptacle installed by a qualified electrician.

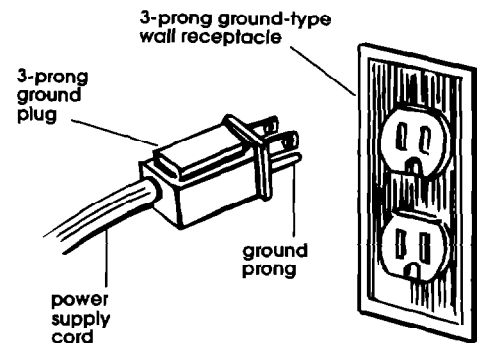
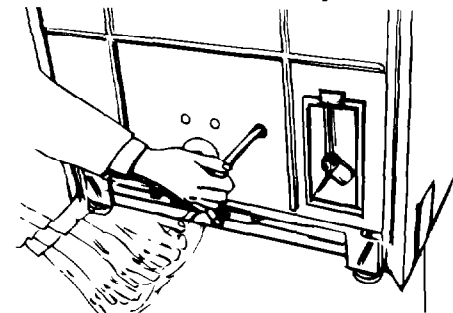

Figure 1

## Now start...

With washer in laundry area.



shipping tape

**Pull the strap completely out of the washer.**

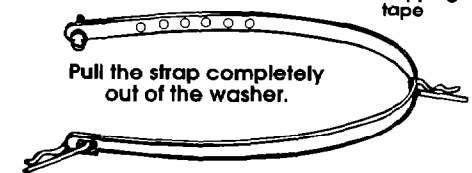

- 1.** Remove tape that covers shipping strap. Pull to completely remove the shipping strap with 2 cotterpins from the inside of the washer.

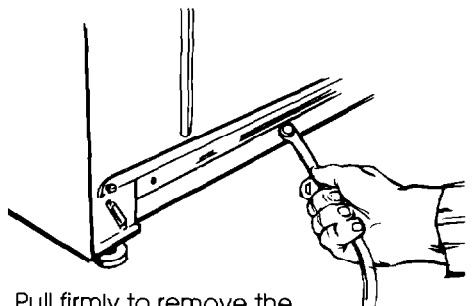

Pull firmly to remove the end of shipping strap from the back of the washer. The shipping strap plug must be completely removed from the washer for the self-leveling legs to be released.

**Save the shipping strap for use in Step 16.**

**2.** Remove the power supply cord from the basket. Peel the tape down and off each side of cabinet.

**Use new hoses and washers that came with your Whirlpool washer.**

Replace inlet hoses after 5 years of use to reduce the risk of hose failure. Inspect and replace inlet hoses if bulges, kinks, cuts, wear, or leaks are found. When replacing your inlet hoses, mark the date of replacement on the label with a permanent marker.

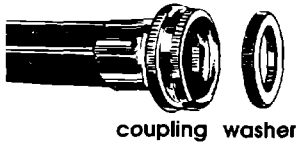

coupling washer

**3.** Insert a flat washer into each end of the inlet hoses. Check that washers are firmly seated in couplings.

**Inlets are plastic. Do Not strip or crossthread.**

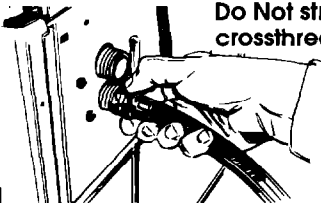

**4.** Attach hose to bottom inlet valve opening first. Then second hose to top inlet. Tighten couplings by hand; then use pliers to make an additional two-thirds turn.

**IMPORTANT: THIS PROCEDURE MUST BE FOLLOWED TO ASSURE PROPER INSTALLATION.**

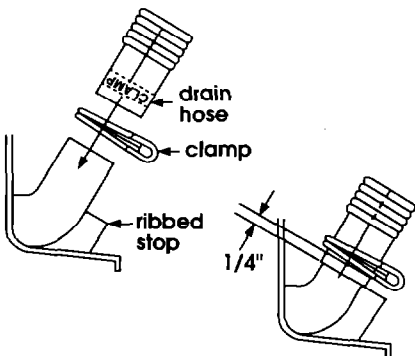

**IMPORTANT: THIS PROCEDURE MUST BE FOLLOWED TO ASSURE PROPER INSTALLATION.**

**5.** To prevent the drain hose from coming off or leaking, it must be installed per the following instructions:

1. Wet the inside end of the drain hose with tap water. **DO NOT USE ANY OTHER LUBRICANT.**
2. Squeeze ears of clamp with pliers to open and place clamp over the end of the drain hose.

3. While holding clamp open, work end of drain hose onto drain connector until drain hose contacts ribbed stop.

4. Position clamp over the drain hose area marked "clamp." Release clamp. Clamp should be 1/4 inch from end of drain hose.

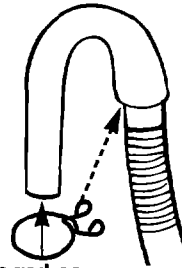

**6.** Open clamp and slide over "hook" end of drain hose to secure the rigid and corrugated sections together.

**Slide washer onto cardboard or hardboard before moving across floor.**

**7.** Move washer close to final position. Put "hook" end of drain hose into laundry tub or standpipe. Check for proper length of drain hose.

**DO NOT FORCE EXCESS LENGTH OF DRAIN HOSE DOWN THE STANDPIPE. THIS COULD CAUSE SIPHONING. See Steps 16.**

**8.** Before attaching water inlet hoses, run water through both faucets into a bucket. This will get rid of particles in water lines that might clog hoses. Mark which is the hot water faucet.



Replace inlet hoses after 5 years of use to reduce the risk of hose failure. Inspect and replace inlet hoses if bulges, kinks, cuts, wear, or leaks are found. When replacing your inlet hoses, mark the date of replacement on the label with a permanent marker.

**9.** Attach bottom hose (inlet marked "H") to hot water faucet. Attach top hose (inlet marked "C") to cold water faucet. Tighten coupling to faucet by hand; then use pliers to make final two-thirds turn.

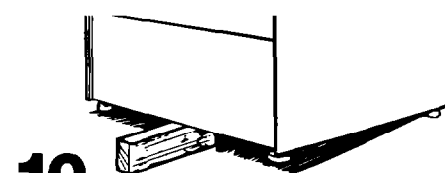

**10.** Carefully tilt washer backward until front of washer is 3-4 inches off floor. Insert piece of wood as brace.

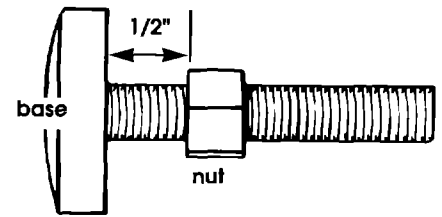

**11.** Use legs and nuts from parts package. Screw nut down to within 1/2 inch of base.

**12.** Insert legs into correct holes at each front corner of washer until nuts touch washer. **Do Not** tighten nuts until Step 15.

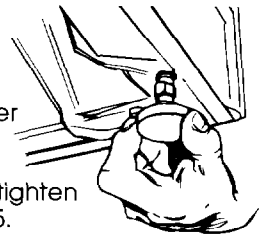

**13.** Tilt washer backward and remove wood block. Gently lower washer to floor.

**Move washer to its permanent location. Remove cardboard or hardboard from under washer.**

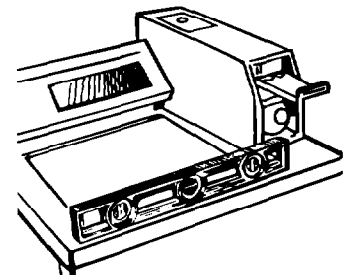

**14.** Tilt washer forward raising back legs 1 inch off of floor. To adjust rear self-leveling legs, gently lower washer to floor. Check levelness of the washer by placing a carpenter's level on top of the washer, first side to side; then front to back.

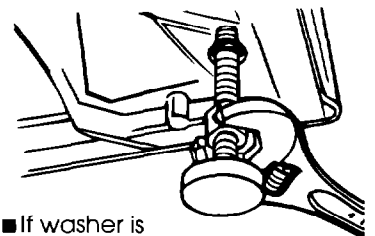

**15.** If washer is not level, adjust the front legs up or down. Make final check with level.

**When washer is level, use wrench to turn nuts on front legs up tightly against washer base. If nuts are not tight against washer base, the washer may vibrate.**

Secure the drain hose to the standpipe with the shipping strap removed from the back of the washer.

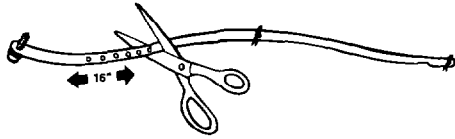

**16.** Measure and mark a point approximately 16 inches from the plug end of the shipping strap. Cut the shipping strap at this point.

**Check that hose is not twisted or kinked and is securely in place.**

Put "hook" end of drain hose into standpipe. Tightly wrap the shipping strap around the drain hose and standpipe. Push plug into the nearest hole in the shipping strap.

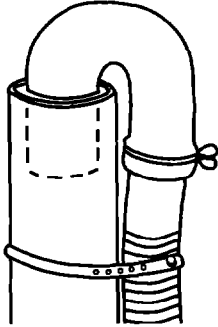

If a longer drain hose is needed, drain hose (Part No. 388423) and hose extension kit (Part No. 285442) are available from authorized parts distributors. If drain hose must be shortened, use kit (Part No. 285442).

**Note: If washer is moved to adjust drain hose, the washer must be leveled again. Repeat Steps 14-15. Place cardboard under the washer and carefully move washer to avoid damaging floor covering.**

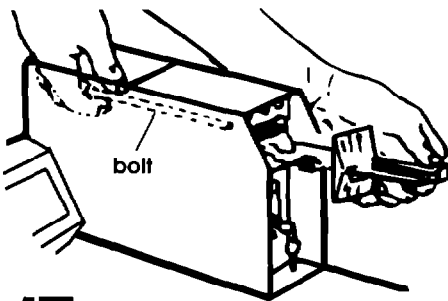

**17.** Remove the service door of the meter case. Lift the service door up at the back and remove. Carefully insert coin drop or coin slide (shown) mechanism with the start switch attached into front opening and secure with the 3/16" mounting bolt from inside the meter case. The coin slide mechanism may need to be partially pushed in to insert mechanism in the front opening. Replace meter case top and service door. Insert coin vault with lock and key.

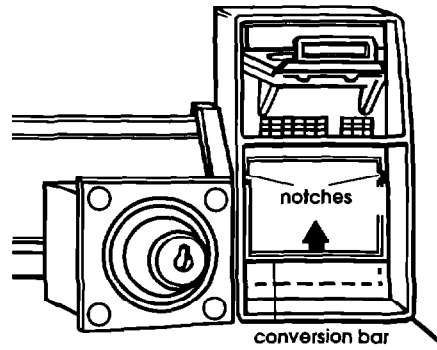

**18.** Put the coin vault with lock and key in the meter case opening. NOTE: A larger-capacity coin vault can be installed. Use a knife to carefully remove the paint along the seam at the bottom of the conversion bar. Use a blade screwdriver and a hammer to lightly tap along the seam area. Raise the conversion bar up to the notches in the sides of the vault opening. Remove the conversion bar and drawer guide. Install new guide (found in parts bag) and the larger coin vault.

**19. CHECK ELECTRICAL REQUIREMENTS. BE SURE YOU HAVE CORRECT ELECTRICAL SUPPLY AND RECOMMENDED GROUNDING METHOD.**

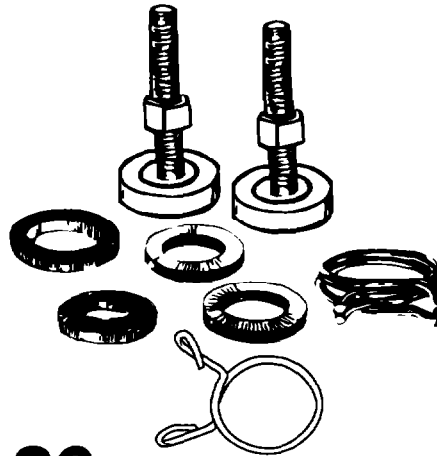

**20.** Check that all parts are now installed. See parts list, Page 3. If there is an extra part, go back through steps to see which step was skipped.

**21.** Turn on water faucets and check for leaks. Tighten couplings if there is leaking. Do Not overtighten; this could cause damage to faucets.

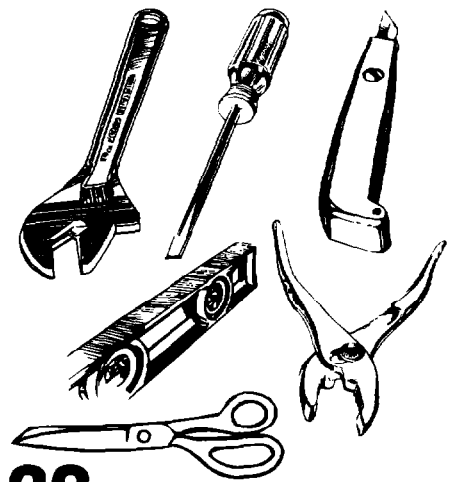

**22.** Check that you have all of your tools. Check that the shipping strap with 2 cotterpins and plug was removed from the back of the washer and used to secure the drain hose.

**If entire strap is not removed, washer may vibrate and be noisy.**

**23.** Untape power supply cord and plug into grounded outlet.

**24.** Check the wash cycle time. Start the washer and allow it to complete a wash cycle. The washer can be advanced through a cycle by following the instructions included with the hand-held terminal. The cycle time can be customized within certain limits by following the instructions included with the hand-held terminal.

## Check list for washer operation

Check the following if the washer is not operating properly:

1. Power supply cord is plugged in.
2. Circuit breaker is not tripped or fuse blown.
3. Timer has been advanced to start of a cycle.
4. Water faucets are turned on.
5. Inlet and drain hoses are not kinked.
6. Washer lid is closed.
7. Inlet valve is frozen if not protected from the weather.
8. Suds level. Excess suds will slow the spin and cause poor rinsing. Operate the washer through a complete cycle with no detergent. Use less detergent or a controlled suds type detergent in future loads.

## Operating Precautions

**⚠ WARNING**



**Explosion Hazard**

**Never place items in the washer that are dampened with gasoline or other flammable fluids.**

**No washer can completely remove oil.**

**Do not dry anything that has ever had any type of oil on it (including cooking oils).**

**Doing so can result in death, explosion, or fire.**

It is recommended that fiberglass items not be washed in coin-operated washers. If these items are washed in the washer, run the washer through a complete cycle to rinse any residue away that might be left in the washer.

## Moving the washer to a new location...

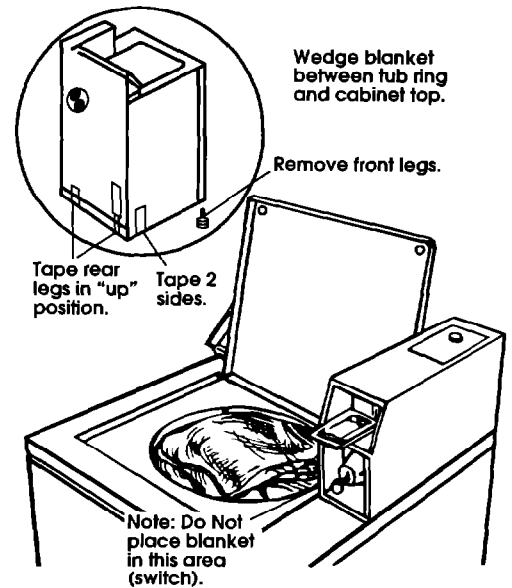

- Remove the front legs from the base of the washer.
- Place both rear leveling legs in the upper position and tape securely.
- Apply tape to the side and bottom of the cabinet near the rear.
- Open washer lid, wedge a blanket between the tub ring and the cabinet top restricting the tub movement.
- Handle washer carefully. **Do Not drop washer while using hand truck.**

## Typical full load sizes.

Load Type	Loading Suggestion	Load Type	Loading Suggestion
Mixed Load	3 double sheets 4 pillowcases 6 pair shorts 8 T-shirts 2 shirts 2 blouses 8 handkerchiefs	Heavy work clothes	3 pair pants 3 shirts 1 coverall 4 pair jeans 1 overall
Permanent Press	2 double or 1 king size sheet 1 tablecloth 1 dress 1 blouse 2 slacks 3 shirts 2 pillowcases	Knits	3 blouses 4 slacks 6 shirts 4 tops 4 dresses

