

# Installation Instructions

## 30" Freestanding Sealed Burner Gas Range with standard clean oven

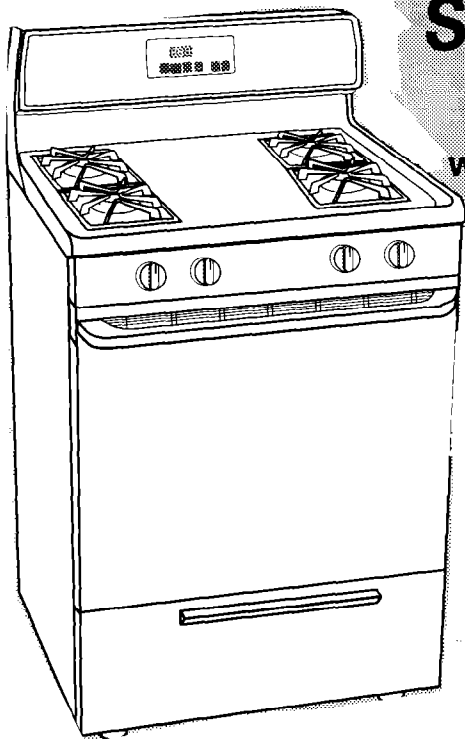

	<p><b>⚠ WARNING</b></p> <ul style="list-style-type: none"><li>• ALL RANGES CAN TIP</li><li>• INJURY TO PERSONS COULD RESULT</li><li>• INSTALL ANTI-TIP DEVICE PACKED WITH RANGE</li><li>• SEE INSTALLATION INSTRUCTIONS</li></ul>
	

## Quick Reference

### Table of Contents:

Pages

<b>1</b>	Before you start
<b>1</b>	Product dimensions
<b>1</b>	Cabinet dimensions/requirements
<b>2</b>	Electrical requirements
<b>2</b>	Gas supply requirements
<b>3 - 6</b>	Installation steps
<b>6 - 7</b>	Gas conversions
<b>Back cover</b>	If range does not operate
<b>Back cover</b>	If you need assistance/service
<b>Back cover</b>	Moving the range

### If you need assistance:

Check your Use and Care Guide for a toll-free number to call or call the dealer from whom you purchased this range. The dealer is listed in the Yellow Pages of your phone directory under "Appliances — Household — Major — Service and Repair."

Call when you:

- Have questions about range installation or operation.
- Need to obtain the name and number of an authorized service company.

When you call, you will need:

- The range model number.
- The range serial number.

Both numbers are listed on the model/serial rating plate located on the frame behind the broiler door.

## IMPORTANT:

## Read and save these instructions.

## IMPORTANT:

**Installer:** Leave Installation Instructions with the homeowner.

**Homeowner:** Keep Installation Instructions for future reference.

Save Installation Instructions for local electrical inspector's use.

9196

## Before you start...

**Important: Observe all governing codes and ordinances.**

This installation must conform with all local codes and ordinances. In the absence of local codes, installation must conform with American National Standard, National Fuel Gas Code ANSI Z223.1 — latest edition\*\*.

**Proper installation** is your responsibility. A qualified technician must install this range. Make sure you have everything necessary for correct installation. It is the installer's responsibility to comply with installation clearances specified on the gas information label. The gas information label and model/serial rating plate are located on the frame behind the broiler door.

**Check location** where range will be installed. The range should be located away from strong draft areas, such as windows, doors and strong heating vents or fans. The range should be located for convenient use in kitchen.

ALL OPENINGS IN THE WALL OR FLOOR WHERE RANGE IS TO BE INSTALLED MUST BE SEALED.

**Cabinet opening dimensions** shown must be used. Given dimensions are minimum clearances.

**Grounded electrical outlet** is required. See "Electrical requirements," Page 2.

**Proper gas supply connection** must be available. See "Gas supply requirements," Page 2.

**WARNING: If the information in this manual is not followed exactly, a fire or explosion may result causing property damage, personal injury or death.**

— **Do Not store or use gasoline, or other flammable vapors and liquids in the vicinity of this or any other appliance.**

— **WHAT TO DO IF YOU SMELL GAS:**

- **Do Not try to light any appliance.**
  - **Do Not touch any electrical switch; Do Not use any phone in your building.**
  - **Immediately call your gas supplier from a neighbor's phone. Follow gas supplier's instructions.**
  - **If you cannot reach your gas supplier, call the fire department.**
- **Installation and service must be done by a qualified installer, service agency or the gas supplier.**

### WARNING



#### Electrical Shock Hazard

It is the customer's responsibility to contact a qualified electrical installer and to make sure that the electrical installation is adequate and make sure the electrical installation follows the National Electrical Code, ANSI/NFPA 70 — latest edition\*, and all local codes and ordinances.

Take special care when cutting holes in wall or floor. Electrical wires may be behind the wall or floor covering and cause electrical shock if you touch them.

Locate any electrical circuits that could be affected by the installation of this product and disconnect power circuit.

Failure to follow these instructions could result in death or serious injury.

#### Fire Hazard

Do Not obstruct the flow of combustion or ventilation air.

Failure to follow this instruction could result in a fire.

#### Injury Hazard

To eliminate the risk of burns or fire, avoid installing cabinet storage above the cooking surface. If cabinets are already installed, reduce the hazard of reaching over a heated cooking surface by installing a range hood. The range hood should extend a minimum of 5 inches out from the bottom front of the cabinets.

Reaching over a heated cooking surface could result in a serious burn or other injury.

## Product dimensions

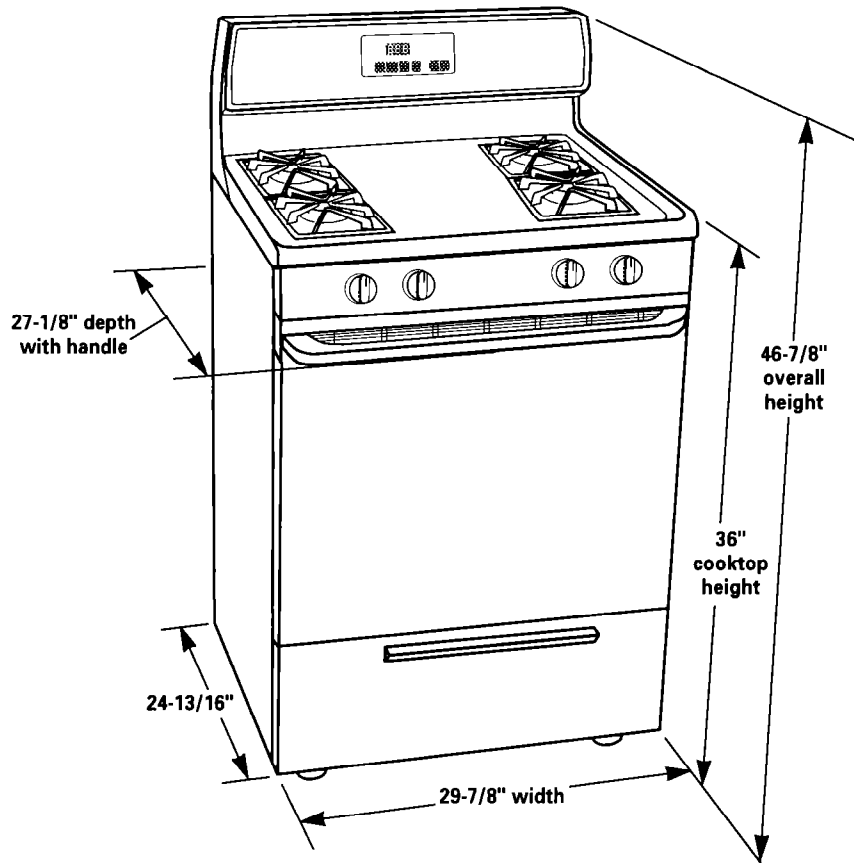

## Cabinet dimensions/requirements

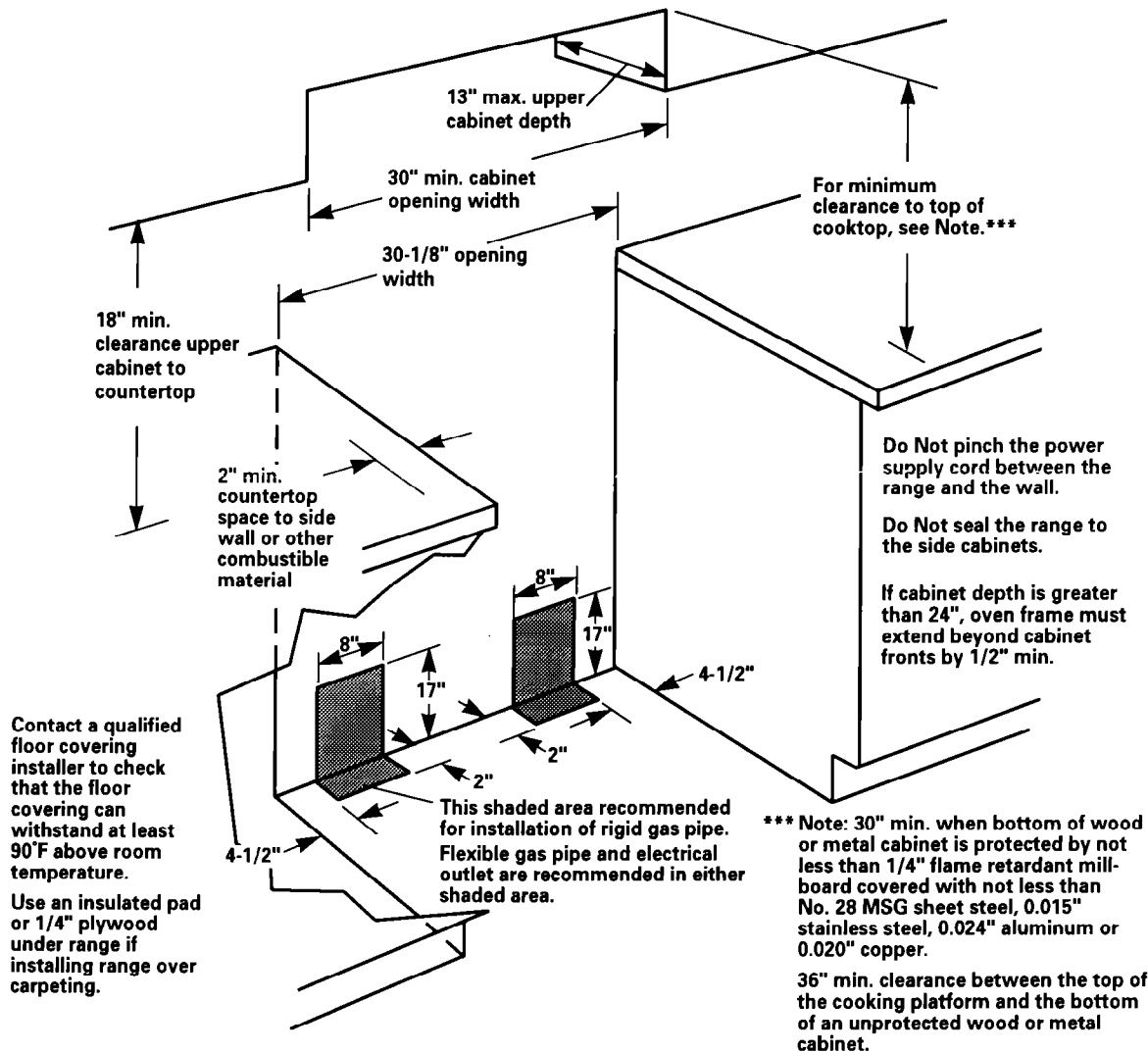

### Anti-tip bracket

The floor-mounted anti-tip bracket **MUST** be installed. To install the anti-tip bracket supplied, see Pages 3-4 and the anti-tip bracket template/instruction sheet.

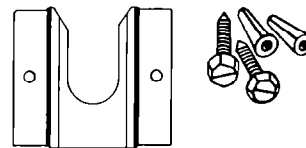

### Mobile home installation

The installation of this range must conform with the Manufactured Home Construction and Safety Standard, Title 24 CFR, Part 3280 [formerly the Federal Standard for Mobile Home Construction and Safety, Title 24, HUD (Part 280)] or, when such standard is not applicable, the Standard for Manufactured Home Installations, ANSI A225.1 and Manufactured Home Installations, Sites, and Communities ANSI/NFPA 501A, or with local codes.

When this range is installed in a mobile home, it must be secured to the floor during transit. Any method of securing the range is adequate as long as it conforms to the standards listed above.

Copies of the standards listed may be obtained from:

\* **National Fire Protection Association**  
Batterymarch Park  
Quincy, Massachusetts 02269

\*\* **American Gas Association**  
1515 Wilson Boulevard  
Arlington, Virginia 22209

### Parts supplied:

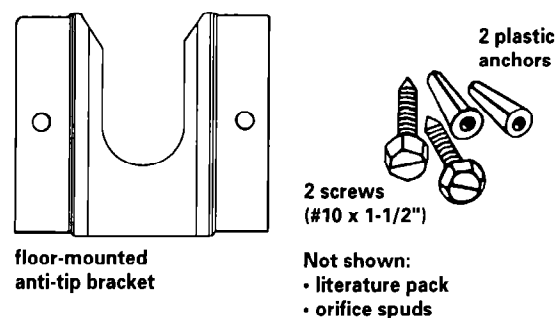

floor-mounted anti-tip bracket

2 screws (#10 x 1-1/2")

Not shown:  
• literature pack  
• orifice plugs

Bracket must be securely mounted to sub-floor. Thickness of flooring may require longer screws to anchor bracket to sub-floor. Longer screws are available from your local hardware store.

## Tools needed:



### Materials required:

- gas line shutoff valve
- 1/2" male pipe thread for connection to pressure regulator
- L.P. gas-resistant pipe-joint compound
- A.G.A. design-certified flexible metal connector (4-5 feet) or rigid gas supply line as needed
- Insulated pad or 1/4" plywood if range is installed over carpeting

## Electrical requirements

### ⚠ WARNING



### Electrical Shock Hazard

This appliance is equipped with a three-prong grounding plug for your protection against shock hazard and should be plugged directly into a properly grounded receptacle.

Electrical ground is required on this range.

**Do Not ground to a gas pipe.**

**Do Not cut or remove the grounding prong from this plug. If the plug will not fit the outlet, have a proper outlet installed by a qualified electrician.**

**Do Not have a fuse in the neutral or grounding circuit. A fuse in the neutral or grounding circuit could result in an electrical shock.**

**Do Not use an extension cord with this range.**

**Check with a qualified electrician if you are not sure the range is properly grounded.**

**Failure to follow these instructions could result in death or serious injury.**

If codes permit and a separate grounding wire is used, it is recommended that a qualified electrician determine that the grounding path is adequate.

A 120-volt, 60-Hz, AC-only, 10-ampere, fused electrical supply is required. A time-delay fuse or circuit breaker is recommended. It is recommended that a separate circuit serving only this appliance be provided.

Electronic ignition systems operate within wide voltage limits, but proper grounding and polarity are necessary. In addition to checking that the outlet is correctly grounded, the outlet must be checked by a qualified electrician to see if it is wired with correct polarity.

A wiring diagram is included on the back of the range.

See "Cabinet dimensions/requirements," Page 1, for recommended location of electrical outlet.

## Recommended grounding method

For your personal safety, this range must be grounded. This range is manufactured with a power supply cord having a 3-prong grounding plug. To minimize possible shock hazard, the cord must be plugged into a mating, 3-prong, grounding-type, wall receptacle, grounded in accordance with National Electrical Code, ANSI/NFPA 70 — latest edition\* and all local codes and ordinances.

If a mating wall receptacle is not available, it is the responsibility and obligation of the customer to have a properly grounded, 3-prong, wall receptacle installed by a qualified electrician.

Copies of the standards listed may be obtained from:

\* National Fire Protection Association  
Batterymarch Park  
Quincy, Massachusetts 02269

3-prong grounding-type wall receptacle

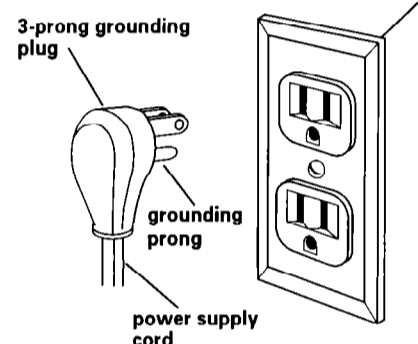

## Gas supply requirements

### ⚠ WARNING



### Fire Hazard

**Range must be connected to a regulated gas supply.**

**Gas supply must NOT exceed 14-inch water column pressure. This must be checked by a qualified technician before installing the range.**

**Do Not use an open flame to test for leaks from gas connections.**

**New A.G.A. design-certified flexible gas line should be used when local codes permit.**

**Failure to follow these instructions could result in a fire or injury.**

Observe all governing codes and ordinances.

**This installation must conform with all local codes and ordinances.** In the absence of local codes, installation must conform with American National Standard, National Fuel Gas Code ANSI Z223.1 — latest edition\*\*.

**Input ratings** shown on the model/serial rating plate are for elevations up to 2,000 feet. For assistance when installing the range at higher elevations, contact your local service company.

**Type of gas:** This range is factory set for use with Natural gas. It is design-certified by the American Gas Association (A.G.A.) for Natural or L.P. gases with appropriate conversion. (See "Gas conversions" instructions, Pages 6-7.) The model/serial rating plate (located on the frame behind the broiler door) has information on the type of gas that can be used. If the type of gas listed does not agree with the type of gas available, check with the local gas supplier. **Conversion must be done by a qualified service technician.**

**Gas supply line:** Provide a gas supply line of 3/4" rigid pipe to the range location. With L.P. gas, piping or tubing size can be 1/2" minimum. A smaller size pipe on longer runs may result in insufficient gas supply. Usually, L.P. gas suppliers determine the size and materials used in the system.

**Pipe-joint compounds** made for use with L.P. gas must be used.



**Flexible metal appliance connection:** If local codes permit, a new A.G.A. design-certified, 1/2" or 3/4" I.D., flexible metal appliance connector is recommended for connecting range to the gas supply line. A 1/2" male pipe thread is needed for connection to pressure regulator female pipe threads. **Do Not kink or damage the flexible metal tubing when moving the range.**

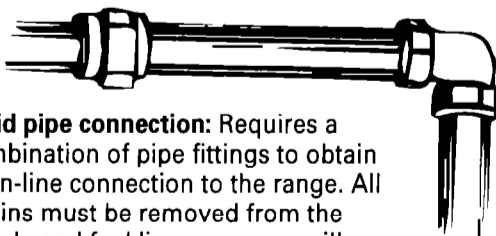

**Rigid pipe connection:** Requires a combination of pipe fittings to obtain an in-line connection to the range. All strains must be removed from the supply and fuel lines so range will be level and in line.

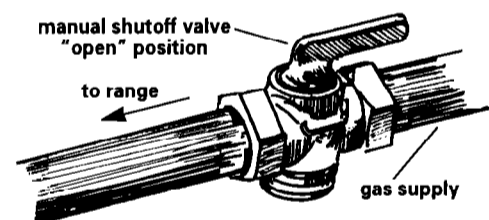

**Shutoff valve:** The supply line must be equipped with a manual shutoff valve. This valve should be located in the same room as the range and should be in a location that allows ease of opening and closing. The valve is for turning on or shutting off gas to the range. **Do Not block access to shutoff valve.**

**Pressure regulator:** The gas pressure regulator supplied with this range must be used. The inlet pressure to the regulator should be as follows for proper operation:

### NATURAL GAS:

Minimum pressure: 5 inches WCP  
Maximum pressure: 14 inches WCP

### L.P. GAS:

Minimum pressure: 11 inches WCP  
Maximum pressure: 14 inches WCP

Contact your local gas supplier if you are not sure about the inlet pressure.

**Line pressure testing above 1/2 psi gauge (14" WCP) —** The range and its individual manual shutoff valve must be disconnected from the gas supply piping system during any pressure testing of that system at test pressures equal to or greater than 1/2 psig (3.5 kPa).

**Line pressure testing at 1/2 psi gauge (14" WCP) or lower —** The range must be isolated from the gas supply piping system by closing its individual manual shutoff valve during any pressure testing of that system at test pressures equal to or less than 1/2 psig (3.5 kPa).

Copies of the standards listed may be obtained from:

\*\* American Gas Association  
1515 Wilson Boulevard  
Arlington, Virginia 22209

**D** Plug power supply cord into grounded outlet

**D** Make proper gas connection

**B** Install anti-tip bracket

**C** Secure range with anti-tip bracket

**E** Check burner operation

**E** Check cooktop burners for proper flame

**A** Remove shipping material.

Remove oven racks and parts package.

**C** Level range

**D** Replace or close broiler door

## Installation steps

### A Preparation

#### ⚠ WARNING

##### Injury Hazard

Because of the weight and size of this range, two or more people are required to move it.

Do Not use handle for lifting.

Failure to follow these instructions could result in injury.

**1.** Put on safety glasses and gloves. Do Not use oven door handle to lift or move the range.

**2.** Remove oven racks and parts package from inside oven. Remove shipping materials, tape and protective film from range.

**3.** Keep cardboard shipping base under range to prevent damage to floor covering.

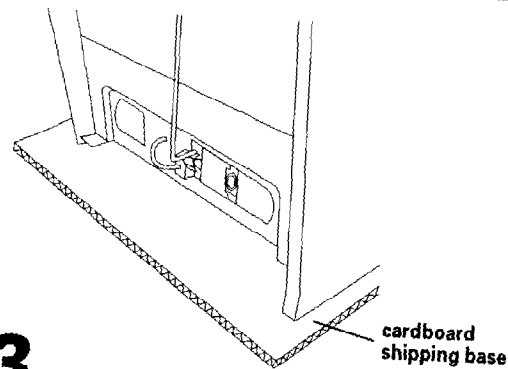

cardboard shipping base

### B Anti-tip bracket installation

#### ⚠ WARNING

##### Electrical Shock

Take special care when drilling holes in the floor or wall. Electrical wires may be behind the wall or floor covering and could cause an electrical shock if you touch them.

Locate the electrical circuits that could be affected by the installation of the anti-tip bracket and turn off power to these circuits.

Failure to follow these instructions could result in death or serious injury.

##### Injury Hazard

To reduce the risk of tipping of the range, the range must be secured by a properly installed floor-mounted anti-tip bracket, supplied with the range.

Save these Installation Instructions. If the range is moved to a new location, the anti-tip bracket must be removed and reinstalled in the new location.

Failure to follow these instructions could result in injury.

Contact a qualified floor covering installer for the best procedure for drilling mounting holes through your type floor covering.

**4.** Use the anti-tip bracket template/instruction sheet to install the anti-tip bracket.

Anti-tip bracket must be anchored securely to the sub floor.

Depending on the thickness of your flooring, longer screws may be needed to anchor the bracket to the sub floor. Longer screws are available from your local hardware store.

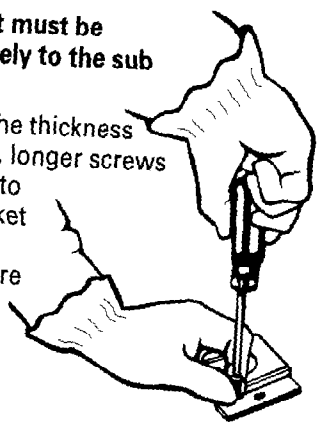

## C Operating position

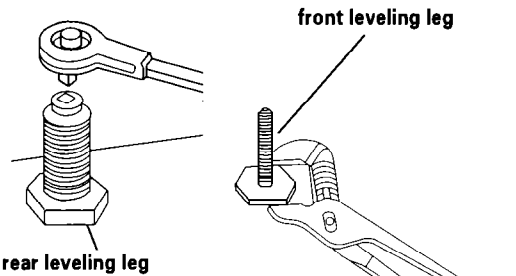

**5.** Remove cardboard shipping base from under range. Open broiler door. Use a 3/8" drive ratchet to lower rear leveling legs one-half turn. Use channel lock pliers to lower front leveling legs one-half turn.

Before moving range across floor, check that range is still on cardboard shipping base to protect floor covering.

**6.** Carefully move range into final operating position. Check that rear leveling leg is engaged in anti-tip bracket.

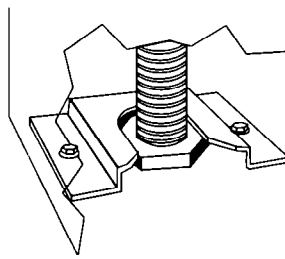

**7.** If installing the range in a mobile home, you **MUST** secure the range to the floor. Any method of securing the range is adequate as long as it conforms to the standards in the "Mobile home installation" instructions, Page 1.

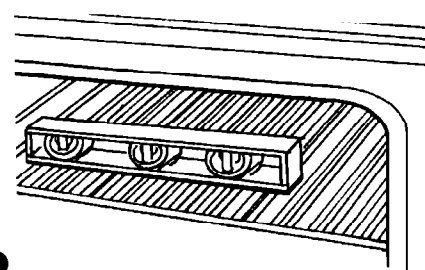

**8.** Place rack in oven. Place level on rack, first side to side; then front to back.

If range is not level, pull range forward until rear leveling leg is removed from the anti-tip bracket. Use 3/8" drive ratchet and channel lock pliers to adjust leveling legs up or down until range is level. Push range back into position. Check that rear leveling leg is engaged in anti-tip bracket.

**Note:** Oven must be level for satisfactory baking conditions.

## D Gas and electrical connections

### WARNING



#### Fire Hazard

**Do Not make connection too tight. The regulator is die cast. Making the connection too tight may crack the regulator, resulting in a gas leak and possible explosion or fire.**

**Do Not use an open flame to test for leaks from gas connections.**

**Failure to follow these instructions could result in a fire or explosion.**

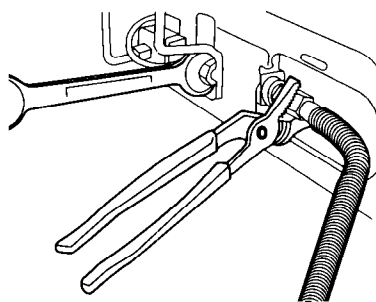

Use 15/16" combination wrench and channel lock pliers to tighten fittings and flexible connector.

**10.** Use pipe-joint compound made for use with L.P. gas to seal all gas connections. If flexible connectors are used, be certain connectors are not kinked.

**12.** Use a brush and liquid detergent to test all gas connections. Bubbles around connections will indicate a leak. If a leak appears, shut off gas valve controls and tighten connections. Then check connections again. **Never test for gas leaks with a match or other flame.** Clean all detergent from range. Replace broiler door.

**13.** Center the burner cap on burner base. Burner cap should be level when properly positioned. Place burner grates over burner.

**14.** Plug power supply cord into grounded electrical outlet.

All connections must be wrench-tightened.

#### Typical rigid pipe connection

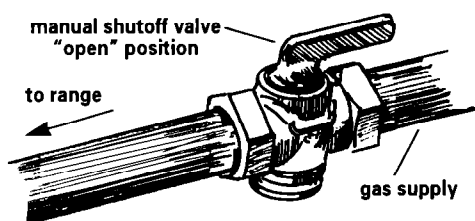
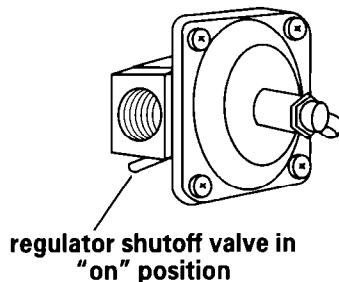
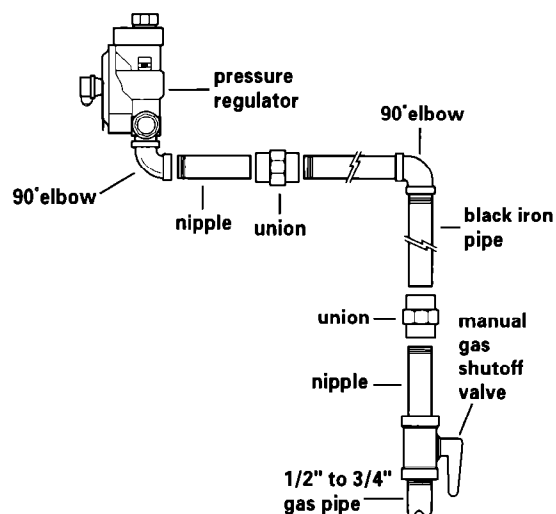

**11.** Check that range regulator shutoff valve is in the "on" position. Open the manual shutoff valve in the gas supply line. Wait a few minutes for gas to move through the gas line.

#### Typical flexible connection

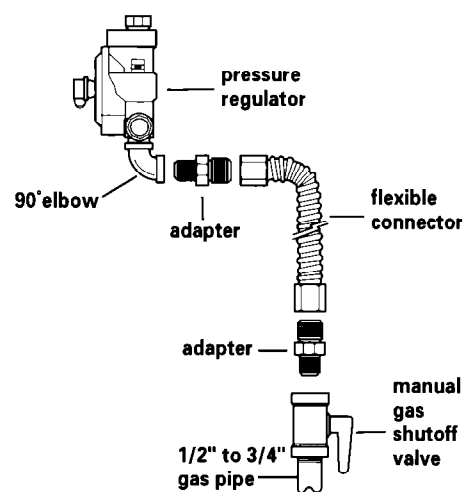

maximum length 21-1/2"

A 1/2" male pipe thread is needed for connection to pressure regulator female pipe threads.

**9.** Assemble the flexible connector from the gas supply pipe to the pressure regulator.

## E Check operation

### Electronic ignition system

Cooktop and oven burners use electronic ignitors in place of standing pilots. When a cooktop control knob is turned to the "LIGHT" position, the system creates a spark to light the burner. This sparking continues until the control knob is turned to the desired setting.

When the oven control is turned to the desired setting, a hot surface ignitor heats up bright orange and ignites the gas. No sparking occurs and the glow bar remains on while the burner operates.

### Check operation of cooktop

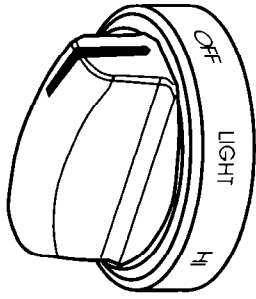

**15.** Push in and turn each surface unit control knob to "LIGHT" position. The flame should light within 4 seconds. Turn control knob to "HI" position after burner lights. **Do Not leave the knob in the "LIGHT" position after burner lights.**

**Check each cooktop burner for proper flame.** The small inner cone should have a very distinct blue flame 1/4" to 1/2" long. The outer cone is not as distinct as the inner cone. If the flame is noisy or blowing, it is getting too much air. If the flame is soft and lazy, it is not getting enough air. Turn surface burner control knobs to "OFF" position. Adjust air shutter if needed.



#### If surface burners need adjusting:

1. Remove control knobs. **Do Not use a metal blade to pry off control knob; this could damage the product. If the control knob cannot be easily removed, tuck a cloth under the knob and pull out on the cloth with steady, even pressure to remove the knob.**
2. Open oven door and remove 3 screws from bottom of manifold panel. Pull down slightly on manifold panel and pull panel away from range.

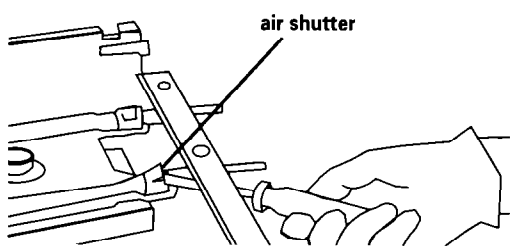

3. Using a flat-blade screwdriver, adjust the air shutter for each burner as needed. Close the air shutter to decrease the amount of air to the flame. Open the air shutter to increase the amount of air to the flame. Adjust the air shutter to the widest opening that will not cause the flame to lift or blow off of the burner.
4. Repeat the first part of Step 15 after adjusting the air shutters.
5. Replace manifold panel by tightening 3 screws in bottom of manifold panel.
6. Replace control knobs on valve stems.

### Check operation of oven burner

**16.** Open broiler door. Follow the instructions for your type of oven controls.

#### If your range has an oven temperature control knob:

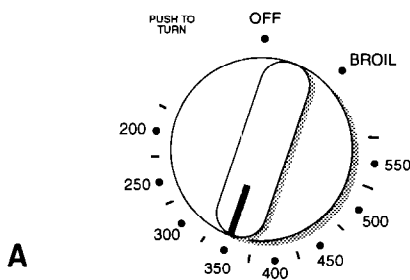

A

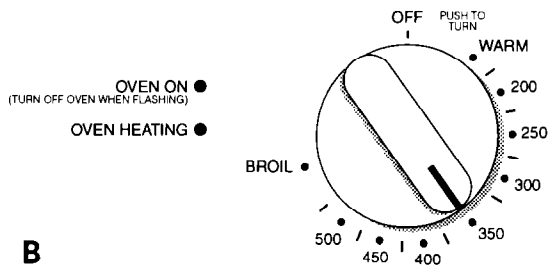

B

Push in and turn the oven selector control knob to "350°F." **The oven burner should light in 50-60 seconds; this delay is normal.** The oven valve requires a certain time before it will open and allow gas to flow.

#### If your oven has this type of electronic control pads (with or without timer):

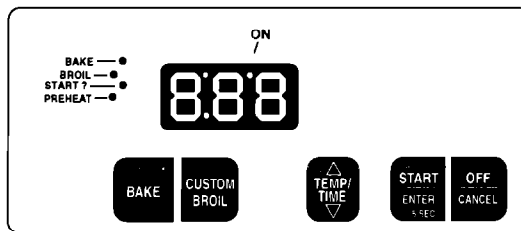

A

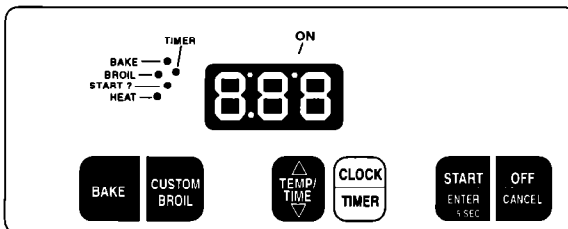

B

If your oven has electronic control pads only:

1. Press the "BAKE" pad.
  - The "BAKE" indicator will light.
  - "350" will appear in the display.
  - The "START?" indicator will begin to flash after 5 seconds.
2. Press the START/ENTER pad.
  - The "PREHEAT" or "HEAT," and "ON" indicators will appear.
  - The display will show the automatic countdown time (10 minutes) needed to preheat the oven for selected temperature.
  - **The oven burner should light in 50-60 seconds; this delay is normal.** The oven valve requires a certain time before it will open and allow gas to flow.
  - The oven is preheated when the "PREHEAT" indicator light goes off (console A only), you hear a 1-second tone and the countdown changes to "350".

\* Note: "PREHEAT" indicator light will not be displayed if oven temperature is over 170°F.

#### If your oven has this type of electronic control pads:

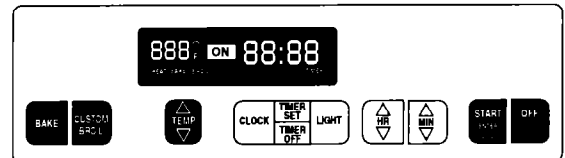

C



D

1. Press the "BAKE" pad.
  - The "BAKE" indicator will light.
  - "350°F" will appear in the display.
  - The "START?" indicator will begin to flash after 5 seconds (console D only).
2. Press the START/ENTER pad.
  - "PrE," and "10:00" will appear in the display.
  - "HEAT" and "ON" indicators will light.
  - The oven is preheated when the time in the display counts down to "0:00," you hear a 1-second tone, and "PrE" changes to "350°F."

**To avoid damaging the hot surface ignitor, do Not insert any object into the openings of the protective shield that surrounds the ignitor or clean that area.**

**17.** Check the oven burner for proper flame. The flame should be 1/2" long, with inner cone of bluish-green, and outer mantle of dark blue, and should be clean and soft in character. No yellow tips, blowing or lifting of flame should occur. **If burner does not light, check that the regulator shutoff valve is in the "on" position (see Step 11).**

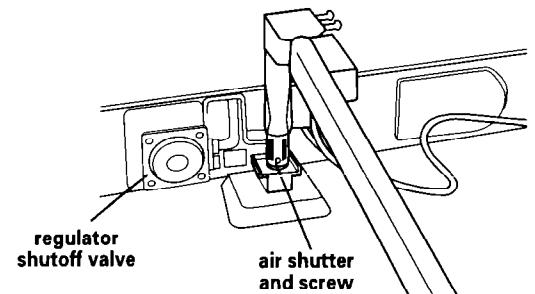

#### If oven flame needs adjusting:

Locate the air shutter next to the pressure regulator. Loosen screw and adjust the air shutter until the proper flame appears. Tighten screw.

**18.** Turn the control knob to "OFF" or press the "OFF/CANCEL" pad.

### Check operation of broil burner

**19.** Broil burner and oven burner are the same burner. Follow the instructions for your type of oven controls.

#### If your range has an oven temperature control knob:

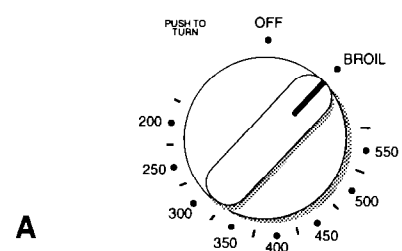

A

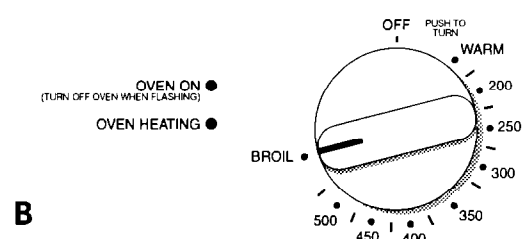

B

Push in and turn the oven selector control knob to "BROIL." **The broil burner should light in 50-60 seconds; this delay is normal.** The oven valve requires a certain time before it will open and allow gas to flow.

## E Check operation (cont.)

If your oven has this type of electronic control pads (with and without timer):

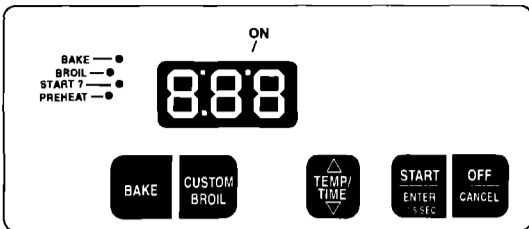

A

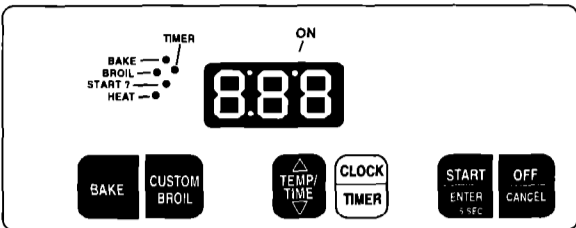

B

1. Press the "CUSTOM BROIL" pad.
  - "525" or "HI" will appear in the display.
  - The "BROIL" indicator will light.
  - The "START?" indicator will begin to flash after 5 seconds.
2. Press the "START/ENTER" pad.
  - "HEAT" (console B only) and "ON" indicators will light.
  - **The oven burner should light in 50-60 seconds; this delay is normal.** The oven valve requires a certain time before it will open and allow gas to flow.

If your oven has this type of electronic control pads:

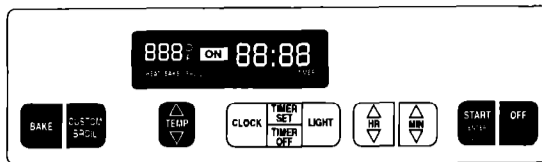

C

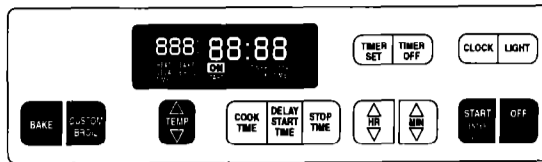

D

1. Press the "CUSTOM BROIL" pad.
  - "HI" will appear in the display.
  - The "BROIL" indicator will light.
  - The "START?" indicator will begin to flash after 5 seconds.
2. Press the "START/ENTER" pad.
  - "HEAT" and "ON" indicators will light.
  - **The oven burner should light in 50-60 seconds; this delay is normal.** The oven valve requires a certain time before it will open and allow gas to flow.

**20.** Check that the broil burner is operating.

**21.** Close the broiler door. Turn the oven control knob to "OFF" or press the "OFF/CANCEL" pad.

You have just finished installing your new range. To get the most efficient use from your range, read your Use & Care Guide. Keep Installation Instructions and Guide close to range for easy reference. The instructions will make installing the range in another home as easy as the first installation.

## Gas conversions

Gas conversions (from Natural gas to L.P. gas; or from L.P. gas to Natural gas) must be done by a qualified installer.

### WARNING



**Fire Hazard**  
Shut off gas supply line valve.  
Make all conversions before turning gas supply valve back on.  
Failure to follow these instructions could result in explosion, fire or other injury.

## L.P. gas conversion

1. Complete installation sections A-C (Pages 3-4) before converting cooktop to L.P. gas. Check that main gas supply line has been shut off and the power supply cord is disconnected.

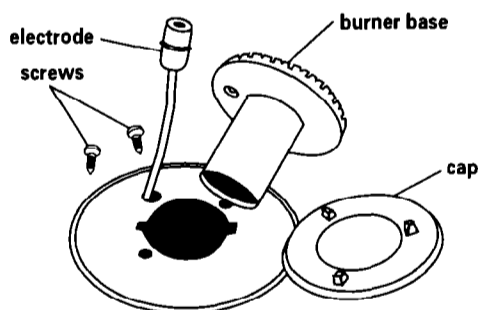

2. Remove burner grates, caps and screws holding burner bases to cooktop. Lift burners off cooktop.

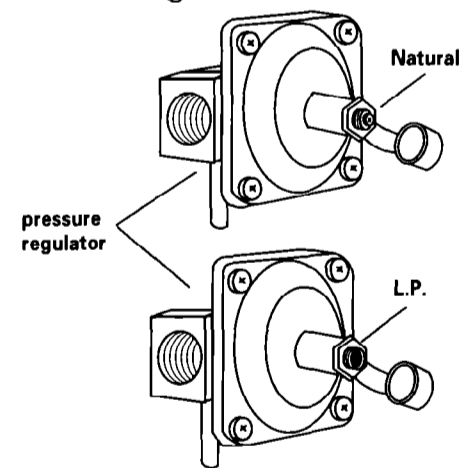
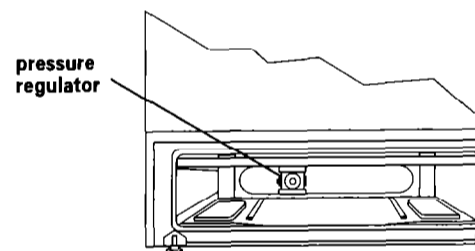

Nat. gas



L.P. gas

**DO NOT REMOVE THE PRESSURE REGULATOR.**

3. Open broiler door to locate pressure regulator.

**Pressure regulator:** Open plastic cover. Turn cap marked "N" on front of pressure regulator counterclockwise with a wrench to remove. **Do Not disturb or remove the spring beneath the cap.** Remove plastic cover, Turn the cap over and reinstall plastic cover on top of cap. Install cap on regulator so that the letters "L.P." are visible. Close plastic cover over cap.

**4. Cooktop burners:** Pull range out from countertop front about 4 inches. There are two clips, one on each side, located underneath the cooktop 2-3/8 inches back from the front of range. Carefully slide a putty knife in between the cooktop and the oven part of range. While gently lifting the cooktop, push in on the putty knife to release the clip. Repeat on other side.

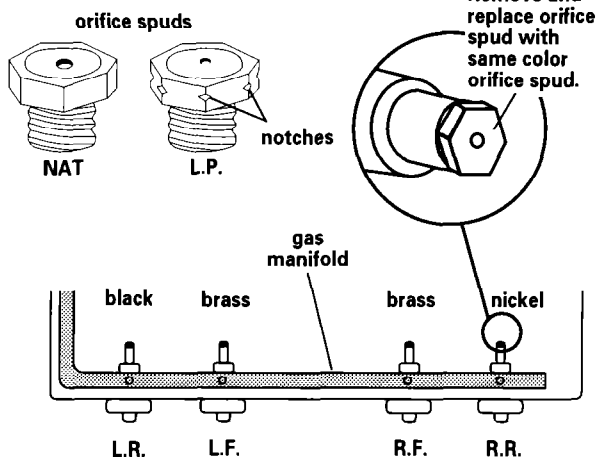

## Natural gas conversion

**1.** Complete installation sections A-C (Pages 3-4) before converting cooktop to natural gas. **Check that main gas supply line has been shut off and the power supply cord is disconnected.**

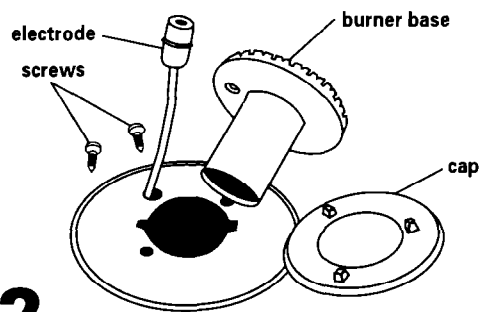

**2.** Remove burner grates, caps and screws holding burner bases to cooktop.

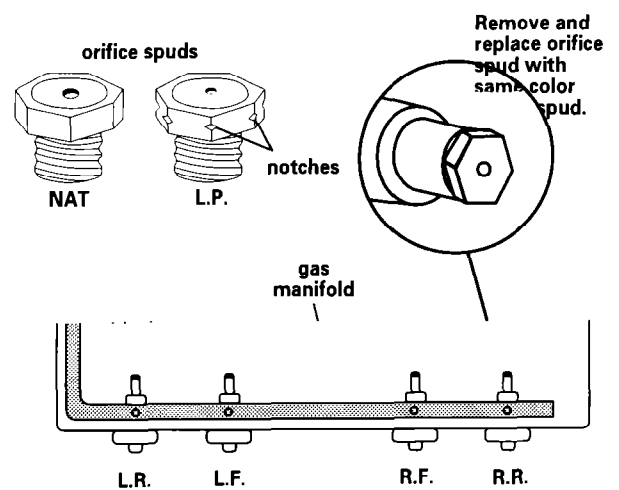
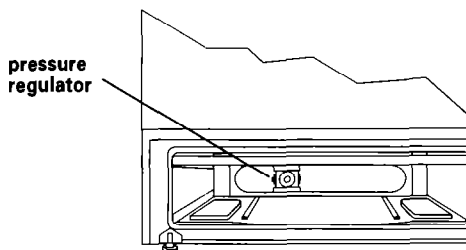

**5. Cooktop burners:** Prop open cooktop maintop. Remove the venturi plates. Locate Natural gas orifice spuds in literature package. Orifice spuds are color coded. Remove one L.P. gas orifice spud at a time using a 3/8" combination wrench. Install the same color Natural gas orifice spud to replace the L.P. gas orifice spud.

Place L.P. gas orifice spuds in plastic parts bag for future use and keep with literature package. Reinstall venturi plates. Lower maintop to operating position and reinstall burner bases, screws, caps and burner grates.

**5.** Prop open cooktop maintop. Remove the venturi plates. Locate L.P. gas orifice spuds in a literature package included with the range. Orifice spuds are color coded. Remove one Natural gas orifice spud at a time using a 3/8" combination wrench. Install the same color L.P. gas orifice spud to replace the Natural gas orifice spud.

Place Natural gas orifice spuds in plastic parts bag for future use and keep with literature package. Reinstall venturi plates. Lower maintop to operating position. Reinstall burner bases, screws, caps and burner grates.

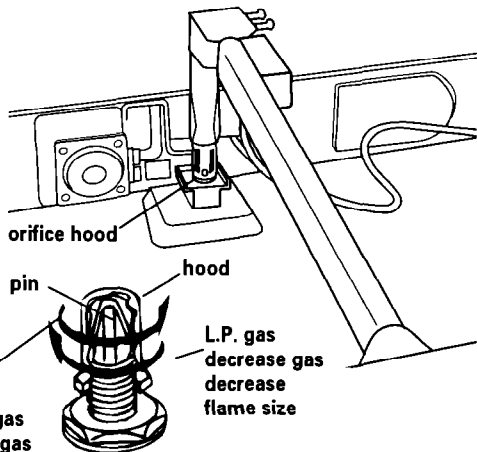

**6. Oven burner:** Use 1/2" combination wrench to turn the orifice hood down snug onto pin (approximately 2 to 2-1/2 turns). **DO NOT OVERTIGHTEN.** The burner flame cannot be properly adjusted if this conversion is not made.

**7.** Complete installation sections D through E, Pages 4-6. Check for proper flame. The small inner cone should have a very distinct blue flame 1/4" to 1/2" long. The outer cone is not as distinct as the inner cone. L.P. gas flames have a slightly yellow tip. If the flame is noisy or blowing, it is getting too much air. If the flame is soft and lazy, it is not getting enough air.

**8.** Carefully move range into final operating position. Check that rear leveling leg is engaged in anti-tip bracket.

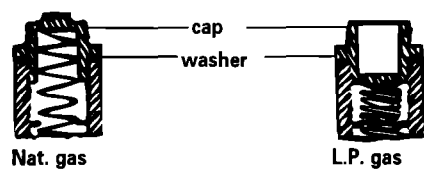
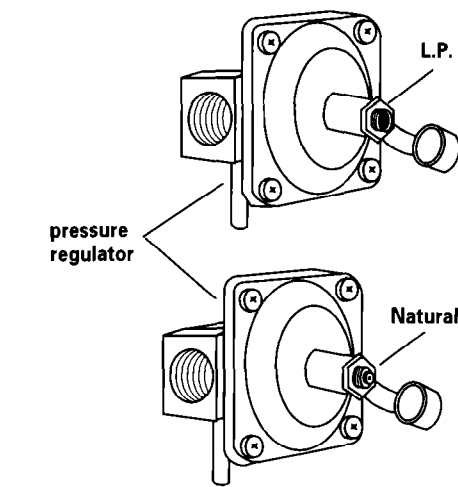
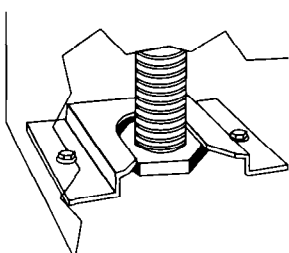

**DO NOT REMOVE THE PRESSURE REGULATOR.**

**3.** Open broiler door to locate pressure regulator.

**Pressure regulator:** Open plastic cover. Turn cap marked "L.P." on front of pressure regulator counterclockwise with a wrench to remove. **Do Not disturb or remove the spring beneath the cap.** Remove plastic cover, Turn the cap over and reinstall plastic cover on top of cap. Install cap on regulator so that the letter "N" is visible. Close plastic cover over cap.

**4. Cooktop burners:**

Pull range out from countertop front about 4 inches. There are two clips, one on each side, located underneath the cooktop 2-3/8 inches back from the front of range. Carefully slide a putty knife in between the cooktop and the oven part of range. While gently lifting the cooktop, push in on the putty knife to release the clip. Repeat on other side.

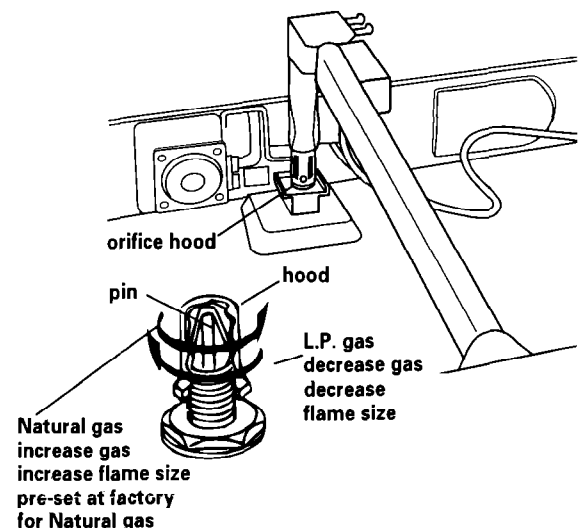
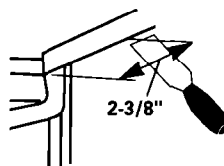

**6. Oven burner:** Use 1/2" combination wrench to loosen the orifice hood away from pin (approximately 2 to 2-1/2 turns). The burner flame cannot be properly adjusted if this conversion is not made.

**7.** Complete installation sections D through E, Pages 4-6. Check for proper flame. Natural gas flames do not have yellow tips.

**8.** Carefully move range into final operating position. Check that rear leveling leg is engaged in anti-tip bracket.

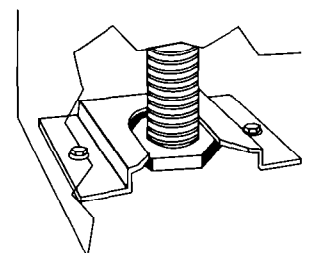



## If range does not operate:

- ✓ Check that the circuit breaker is not tripped or the house fuse blown.
- ✓ Check that the power supply cord is plugged into the wall receptacle.
- ✓ Check that gas line is turned on.
- ✓ See Use and Care Guide for troubleshooting list.

## If you need assistance:

If you have questions about operating, cleaning or maintaining your range:

- ✓ Refer to Use and Care Guide.
- ✓ Call the Consumer Assistance Center. Check your Use and Care Guide for a toll-free number to call or call the dealer from whom you purchased this range. The dealer is listed in the Yellow Pages of your phone directory under "Appliances — Household — Major — Service and Repair."

## If you need service:

Maintain the quality built into your range by calling an authorized service company.

To obtain the name and number of an authorized service company:

- ✓ Contact the dealer from whom you purchased your range; or
- ✓ Look in the Yellow Pages of your telephone directory under "Appliances — Household — Major — Service and Repair;" or
- ✓ Call the Consumer Assistance Center. The toll-free number is listed in your Use and Care Guide.

When you call, you will need:

- ✓ The range model number.
- ✓ The range serial number.

Both numbers are listed on the model/serial rating plate located on the frame behind the broiler door.

## Moving the range:

**⚠ WARNING**



**Injury Hazard**

- **Because of the weight and size of this range, two or more people are required to move it.**
- **All ranges can tip.**
- **Do Not step, lean or sit on the range drawer or door.**
- **The anti-tip device packed with range must be installed. See Installation Instructions.**

**Failure to follow these instructions could result in injury.**

**When moving range, slide range onto cardboard or hardboard to prevent damaging the floor covering.**

If removing the range is necessary for cleaning or maintenance:

1. Shut off the gas supply to the range.
2. Disconnect gas and electrical supplies. If necessary, pull the range out, away from the wall, just far enough to disconnect the gas and electric supply lines.
3. Remove range to complete cleaning or maintenance.
4. Move range back into operating position. Look underneath range (a flashlight may be needed) to check that leg is engaged in anti-tip bracket. If leg is not properly engaged, remove and reposition bracket to insure that leg fits properly in bracket.
5. Check that range is level
6. Reconnect gas line to range and check for leaks.
7. Plug power supply cord into outlet.