

CAUTION: DISCONNECT ELECTRIC CURRENT BEFORE SERVICING. LABEL ALL WIRES PRIOR TO DISCONNECTION WHEN SERVICING CONTROLS. WIRING ERRORS CAN CAUSE IMPROPER AND DANGEROUS OPERATION. VERIFY PROPER OPERATION AFTER SERVICING.

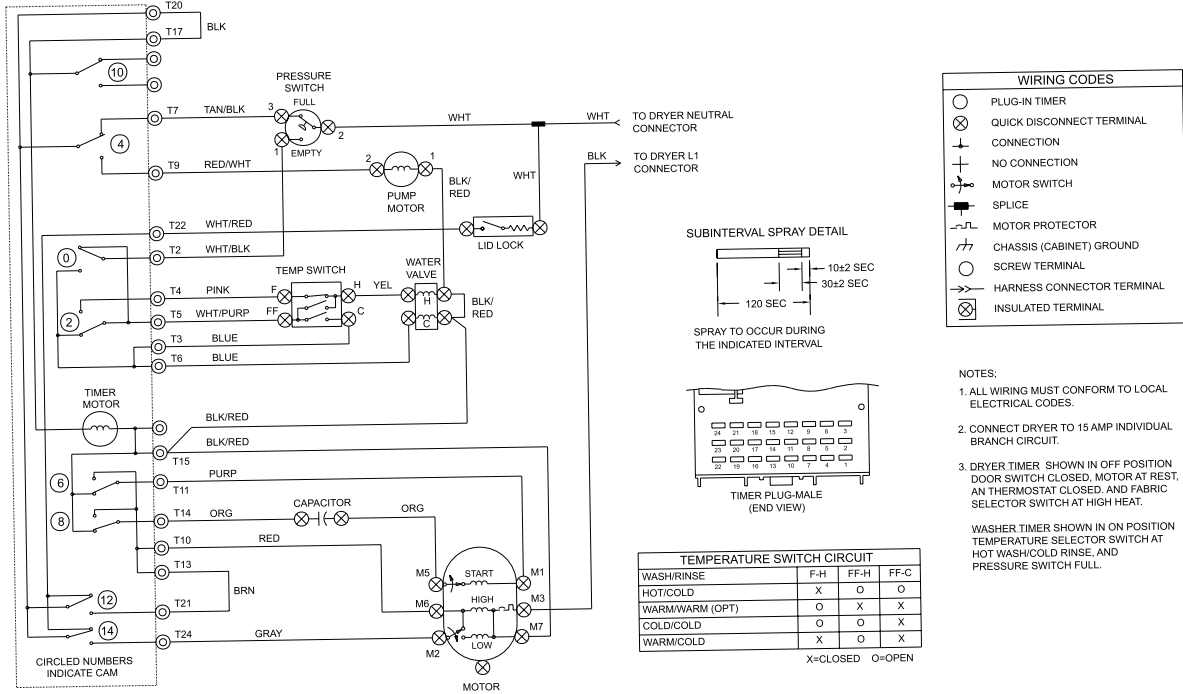
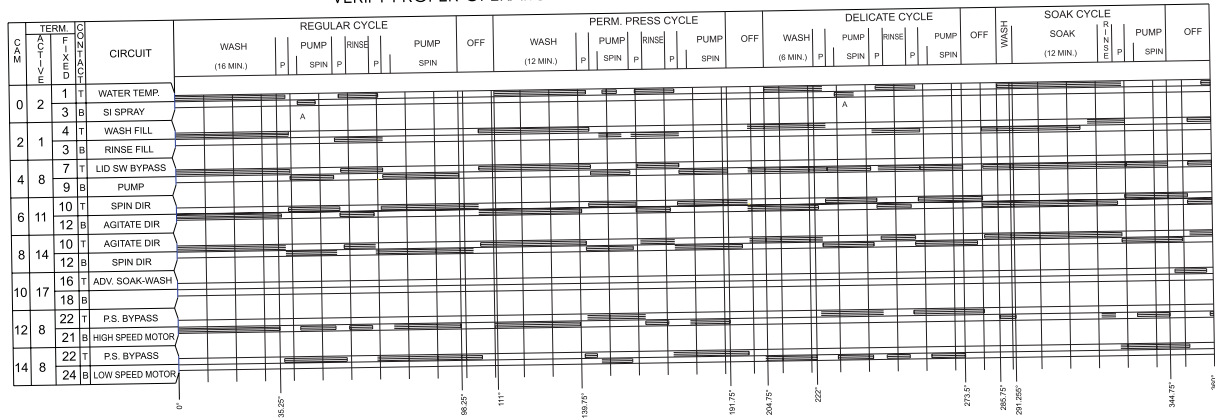

**WIRING CODES**

- PLUG-IN TIMER
- ⊗ QUICK DISCONNECT TERMINAL
- ⊕ CONNECTION
- ⊖ NO CONNECTION
- ⊗ MOTOR SWITCH
- ⊕ SPlice
- ⊗ MOTOR PROTECTOR
- ⊕ CHASSIS (CABINET) GROUND
- SCREW TERMINAL
- ⊗ HARNESS CONNECTOR TERMINAL
- ⊕ INSULATED TERMINAL

- NOTES:**
- ALL WIRING MUST CONFORM TO LOCAL ELECTRICAL CODES.
  - CONNECT DRYER TO 15 AMP INDIVIDUAL BRANCH CIRCUIT.
  - DRYER TIMER SHOWN IN OFF POSITION, DOOR SWITCH CLOSED, MOTOR AT REST, AN THERMOSTAT CLOSED, AND FABRIC SELECTOR SWITCH AT HIGH HEAT.
- WASHER TIMER SHOWN IN ON POSITION, TEMPERATURE SELECTOR SWITCH AT HOT WASH/COLD RINSE, AND PRESSURE SWITCH FULL.

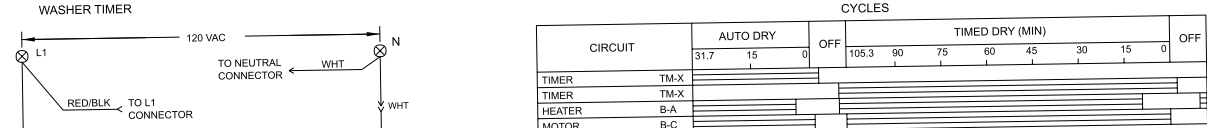

BAR CHART ABOVE REPRESENTS ONE COMPLETE REVOLUTION OF TIMER SHAFT. SHADED PORTION OF BAR CHART INDICATES THE PROPORTIONAL TIMES THAT INTERNAL TIMER CONTACTS ARE CLOSED.

