

SERVICE DATA SHEET - Electric Range with ES 1000 Electronic Oven Control

NOTICE - This service data sheet is intended for use by persons having electrical and mechanical training and a level of knowledge of these subjects generally considered acceptable in the appliance repair trade. The manufacturer cannot be responsible, nor assume any liability for injury or damage of any kind arising from the use of this data sheet.

Safe servicing practices

To avoid the possibility of personal injury and/or property damage, it is important that safe servicing practices be observed. The following are examples, but without limitation, of such practices.

- Before servicing or moving an appliance remove power cord from electrical outlet, trip circuit breaker to OFF, or remove fuse.
- Never interfere with the proper installation of any safety device.
- GROUNDING:** The standard color coding for safety ground wires is **GREEN** or **GREEN WITH YELLOW STRIPES**. Ground leads are not to be used as current carrying conductors. **It is extremely important that the service technician reestablish all safety grounds prior to completion of service. Failure to do so will create a potential safety hazard.**
- Prior to returning the product to service, ensure that:
 - All electric connections are correct and secure.

- All electrical leads are properly dressed and secured away from sharp edges, high-temperature components, and moving parts.
- All uninsulated electrical terminals, connectors, heaters, etc. are adequately spaced away from all metal parts and panels.
- All safety grounds (both internal and external) are correctly and securely reassembled.

Oven Calibration

Set the electronic oven control for normal baking at 350°F. Obtain an average oven temperature after a minimum of 5 cycles. Press **cancel** keypad to end Bake mode.

Temperature Adjustment

- While in a non-cooking mode, press and hold the **bake** key for 6 seconds.
- The current calibration offset (temperature adjustment) should appear in the temperature display.
- Use the number keys (0-9) to enter the desired amount of adjustment (up to 35°F).
- Press the **self clean** key to change the sign of the adjustment to a (-) if necessary. A positive adjustment will not display a sign.
- Once the desired adjustment (-35° to 35°F) has been entered, press the **start** key to accept the change or the **cancel** key to reject the change.

NOTE: Changing calibration affects all Baking modes. The adjustments made will not change the self-cleaning temperature.

Electronic oven control (EOC) & jumper connection locations

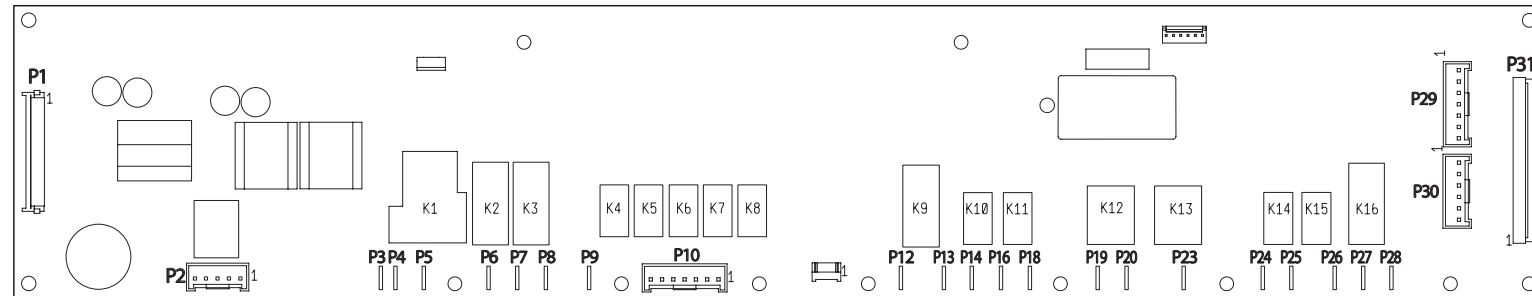

EOC jumper connections

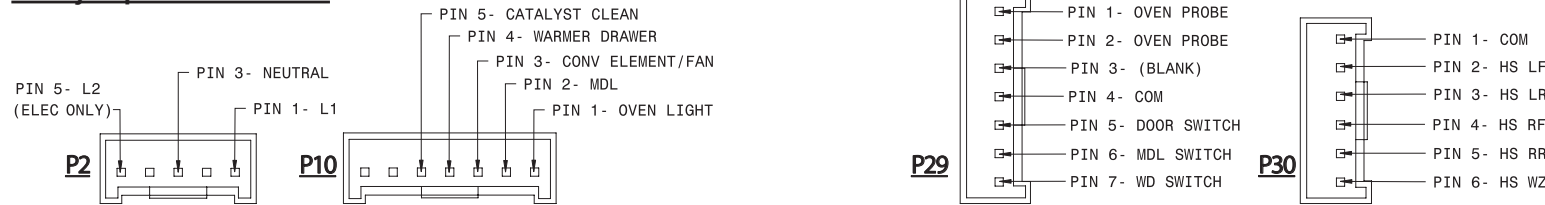

RTD SCALE	
Temperature °F (°C)	Resistance (ohms)
32 ± 1.9 (0 ± 1.0)	1000 ± 4.0
75 ± 2.5 (24 ± 1.3)	1091 ± 5.3
250 ± 4.4 (121 ± 2.4)	1453 ± 8.9
350 ± 5.4 (177 ± 3.0)	1654 ± 10.8
450 ± 6.9 (232 ± 3.8)	1852 ± 13.5
550 ± 8.2 (288 ± 4.5)	2047 ± 15.8
650 ± 9.6 (343 ± 5.3)	2237 ± 18.5
900 ± 13.6 (482 ± 7.5)	2697 ± 24.4
Probe circuit to case ground	Open circuit/infinite resistance

IMPORTANT
DO NOT REMOVE THIS BAG
OR DESTROY THE CONTENTS
WIRING DIAGRAMS AND SERVICE
INFORMATION ENCLOSED
REPLACE CONTENTS IN BAG

p/n 316904449 REV C (1405)

Abbreviations and Terminology	
EOC - Electronic Oven Control	RTD - Resistance Temperature Device (temp probe or sensor)
VSC - Variable Speed Control	MDL - Motor Door Lock
PS - Power Supply board (PS1, PS2, etc)	TCO - Thermal Cut Out (also Thermo Disc or Thermal Limiter)

	Circuit Analysis Matrix								Door Switch Contacts COM-NO
	EOC Relays - ES1005 (Electric Oven)								
	L1 to Bake	L1 to Broil	L1 to MDL	L1 to Conv Bake Fan	L1 to Conv Element	L2 in to L2 Out	L1 to Warming Drawer	L1 to Oven Lamps	
Bake/ Time Bake	X-	X*		X+	X+	X			
Conv Bake	X-	X*		X	X	X			
Broil		X				X			
Clean	X-	X*				X			
Unlocked									
Locking			X						
Locked									
Unlocking			X						
Door Open								X	O
Door Closed								O	X
Oven Lamps ON								X	
Warming Drawer							X-		

Note: X=Check listed circuits O=Circuit Contacts Open *=Alternates with Bake element +=During Preheat -=Cycles as needed.

Electric Oven Control Fault Description		
Fault Code	Likely Failure Condition/Cause	Suggested Corrective Action
F10	Runaway temperature. Oven heats when no cook cycle is programmed.	If Oven is cold: 1. If fault code is present with cold oven test oven temperature sensor probe circuit resistance. Use RTD scale found in the tech sheet. 2. Replace probe or repair wiring connections if defective. 3. If temperature sensor probe circuit is good but fault code remains when oven is cold, replace the EOC. If Oven is overheating: 1. If oven is severely overheating/heating when no cook cycle is programmed test oven temperature sensor probe circuit resistance using the RTD scale found in the service tech sheet. Also verify that the temperature sensor probe is properly installed in the oven cavity. 2. Disconnect power from the range, wait 30 seconds and reapply power. If oven continues to heat when the power is reapplied, replace the EOC. NOTE: Severe overheating may require the entire oven to be replaced should damage be extensive.
F11	Shorted keypad or selector switch.	1. Reset power supply to range - Disconnect power, wait 30 seconds and reapply power. 2. Check/reseat ribbon harness connections between touch panel and EOC. 3. Test keyboard circuits using test matrix. Replace touch panel if defective. 4. If keyboard circuits check good, replace the EOC.
F12	Internal Software error in EOC.	1. Disconnect power, wait 30 seconds and reapply power. If fault returns upon power-up, replace EOC.
F13		
F14	Keyboard tail failure.	1. Check/reseat ribbon harness connections between keyboard touch panel and EOC. 2. Test keyboard circuits using test matrix (below). Replace touch panel if defective. 3. If keyboard circuits check good, replace EOC.
F15	EOC Internal hardware error or failure.	1. Disconnect power, wait 30 seconds and reapply power. If fault returns upon power-up, replace EOC.
F19		
F30	Open probe connection	Check resistance at room temperature & compare to RTD Sensor resistance chart. If resistance is correct replace the EOC. If resistance does not match the RTD chart replace RTD Sensor Probe. Check Sensor wiring harness between EOC & Sensor Probe connector.
F31	Shorted probe connection	Check resistance at room temperature, if less than 500 ohms, replace RTD Sensor Probe. Check for shorted Sensor Probe harness between EOC & Probe connector. If resistance is correct, replace the EOC.
F42	EOC internal software configuration error.	Usually this failure code would only appear if the EOC has been replaced with an incorrect version. Verify that the correct replacement part number is being used.
F60	EOC oven temperature. Higher than normal temperature detected on the EOC board	1. Verify proper assembly of blackguard panel. Check for damaged or loose panels, brackets, end caps, etc. 2. Check for blocked ventilation slots in control panel rear cover. 3. Inspect oven vent for proper assembly and air flow. 4. Verify operation of cooling fan (if present).
F62	Internal signal voltage error. Display communication error.	Disconnect power, wait 30 seconds and reapply power. If fault returns upon power-up, replace EOC.
F63		
F64	Time Base failure - The EOC cannot determine if connected to 50 or 60Hz power supply.	Confirm that range is connected to proper power source (50Hz or 60Hz). Generators or other portable power supplies and solar grids, etc. may not provide proper power supply. If power source is correct, replace the EOC.
F65	Keyboard short circuit or internal EOC failure.	1. Test keyboard circuits using test matrix. Replace touch panel if defective. 2. If keyboard circuits check good replace the EOC
F66	EOC internal power supply failure.	Disconnect power, wait 30 seconds and reapply power. If fault returns upon power-up, replace EOC.
F68	High voltage condition. L1 or L2 may be crossed with Neutral on incoming PS.	1. Verify proper incoming line voltage and polarity of L1, L2 and Neutral power supply connections at range terminal block. 2. If power supply voltage and polarity are correct, replace EOC.
F69		
F90	Door lock motor or latch circuit failure.	If lock motor runs: 1. Test continuity of wiring between EOC and lock switch on lock motor assy. Repair if needed. 2. Advance motor until cam depresses the plunger on lock motor switch. Test continuity of switch contacts. If switch is open, replace lock motor assembly. 3. If motor runs and switch contacts and wiring harness test good, replace the EOC. If lock motor does not run: 1. Test continuity of lock motor windings. Replace lock motor assembly if windings are open. 2. Test lock motor operation by using a test cord to apply voltage. If motor does not operate replace lock motor assy. 3. If motor runs with test cord check continuity of wire harness to lock motor terminals. If harness is good replace the EOC.
F91		
F92		
F93		
F94		
F95		

Keypad Test Matrix

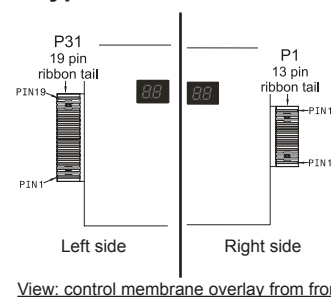

View: control membrane overlay from front

CONNECTOR - PIN #	P31 - 1	P31 - 2	P31 - 3	P31 - 4	P31 - 5	P31 - 6	P31 - 13	P1 - 1	P1 - 2	P1 - 6	P1 - 7
P31 - 7	CLOCK	CONV BAKE	1	3	2	ADD 1 MINUTE	-	-	-	-	-
P31 - 8	WARM & HOLD	PREHEAT	4	6	5	RECIPE RECALL	-	-	-	-	-
P31 - 9	SLOW COOK	BROIL	7	9	8	COOK TIME	-	COOKTOP LOCKOUT	AIR GUARD	-	-
P31 - 10	WMR ON/OFF	BAKE	START	0	CONV CONVERT	DELAY START	-	WZONE ON/OFF	WZONE SELECT	-	-
P31 - 11	STOP/ CLEAR	LIGHT	CLEAN	CONV ROAST	WMR SELECT	TIMER SET/OFF	(CONNECT)	LEFT BURNER SIZE	RIGHT BURNER SIZE	-	-
P31 - 12	(CONNECT)	-	-	-	-	-	-	-	-	-	-
P1 - 3	SURFACE LF OFF	SURFACE LF LOW	SURFACE LF MED	SURFACE LF HI	SURFACE LR OFF	SURFACE LR LOW	-	SURFACE LR MED	SURFACE LR HI	(CONNECT)	-
P1 - 4	SURFACE RF OFF	SURFACE RF LOW	SURFACE RF MED	SURFACE RF HI	SURFACE RR OFF	SURFACE RR LOW	-	SURFACE RR MED	SURFACE RR HI	-	(CONNECT)
P1 - 5	-	-	-	-	(CONNECT)	-	-	-	-	-	-

To test keypad function check for continuity between indicated pin locations while pressing keypad. Example: To test the Bake keypad use pin #2 & pin #10 on connector P31. To test cooktop keypad use pin 1 on connector P1 & pin 9 on connector P31.

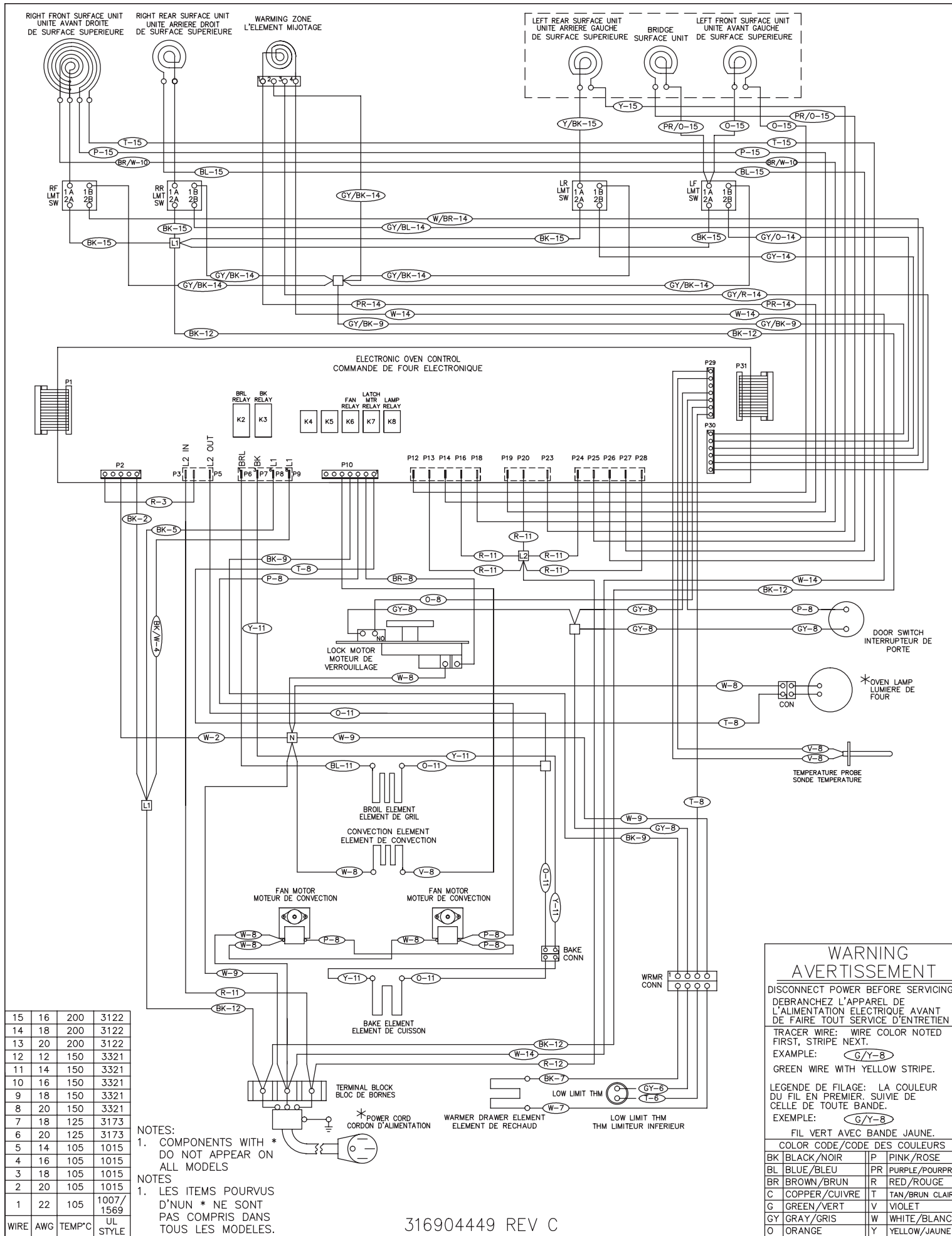

15	16	200	3122
14	18	200	3122
13	20	200	3122
12	12	150	3321
11	14	150	3321
10	16	150	3321
9	18	150	3321
8	20	150	3321
7	18	125	3173
6	20	125	3173
5	14	105	1015
4	16	105	1015
3	18	105	1015
2	20	105	1015
1	22	105	1007/1569
WIRE	AWG	TEMP°C	UL STYLE

316904449 REV C

**WARNING
AVERTISSEMENT**

DISCONNECT POWER BEFORE SERVICING
DEBRANCHEZ L'APPAREIL DE L'ALIMENTATION ELECTRIQUE AVANT DE FAIRE TOUT SERVICE D'ENTRETIEN

TRACER WIRE: WIRE COLOR NOTED FIRST, STRIPE NEXT.
EXAMPLE: **G/Y-B**
GREEN WIRE WITH YELLOW STRIPE.

LEGENDE DE FILAGE: LA COULEUR DU FIL EN PREMIER, SUIVIE DE CELLE DE TOUTE BANDE.
EXAMPLE: **G/Y-B**
FIL VERT AVEC BANDE JAUNE.

BK	BLACK/NOIR	P	PINK/ROSE
BL	BLUE/BLEU	PR	PURPLE/POURPRE
BR	BROWN/BRUN	R	RED/ROUGE
C	COPPER/CUIVRE	T	TAN/BRUN CLAIR
G	GREEN/VERT	V	VIOLET
GY	GRAY/GRIS	W	WHITE/BLANC
O	ORANGE	Y	YELLOW/JAUNE

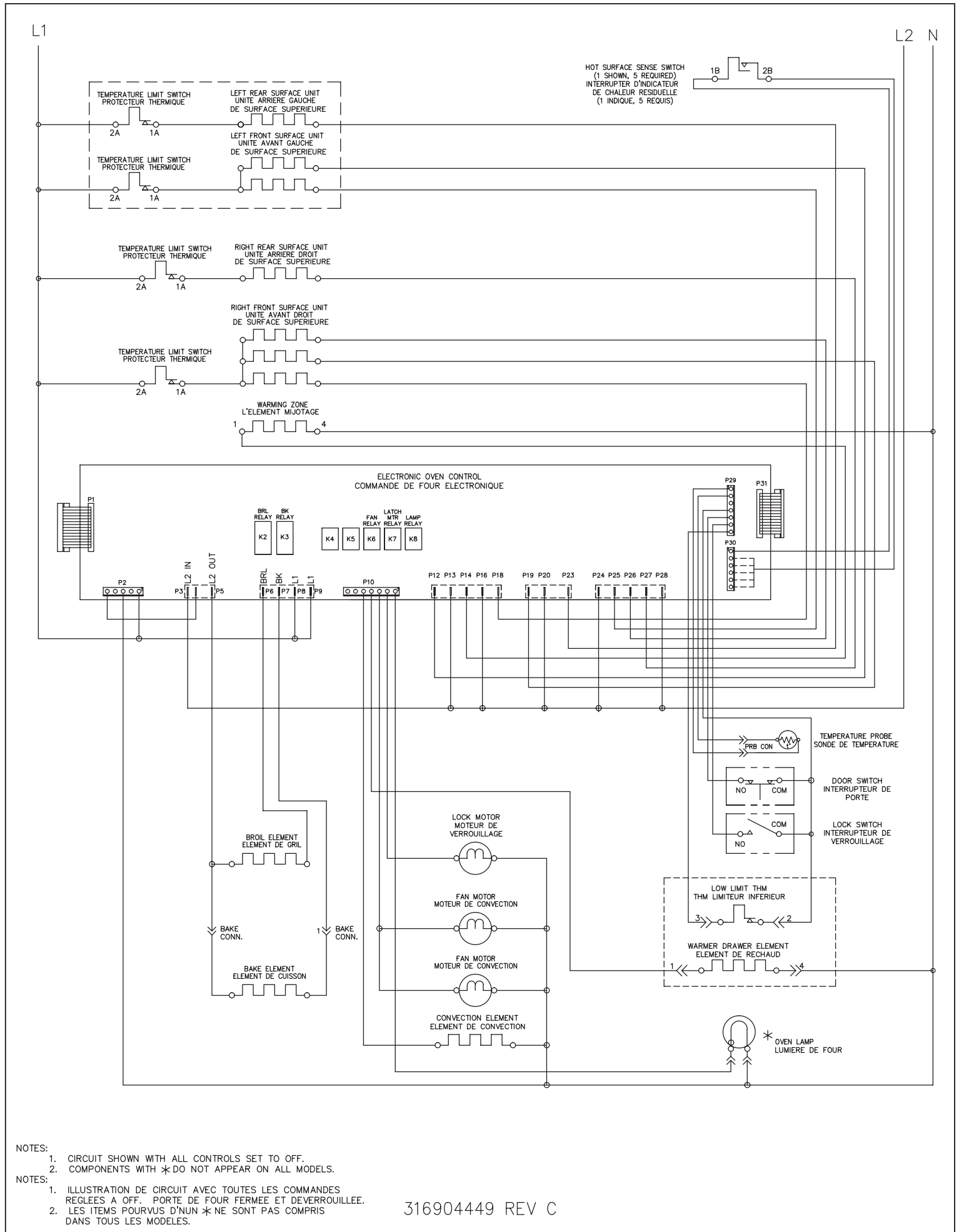

316904449 REV C