

LEGEND/LEYENDA/LEGENDE

C.F. - CENTER REAR/POSTERIOR CENTRAL/ARRIERE CENTRE
R.F. - RIGHT FRONT/FRENTE DERECHO/AVANT DROIT
R.R. - RIGHT REAR/POSTERIOR DERECHO/ARRIERE DROIT
L.F. - LEFT FRONT/FRENTE IZQUIERDO/AVANT GAUCHE
L.R. - LEFT REAR/POSTERIOR IZQUIERDO/ARRIERE GAUCHE
LIM. - ELEMENT LIMITOR/ELEMENTO LIMITADOR/LIMITEUR ELEMENT
ELM. - ELEMENT/ELEMENTO/ELEMENT
H.S. - HOT SURFACE/SUPERFICIE CALIENTE/SURFACE CHAUDE
T.B. - TERMINAL BLOCK/BLOQUE DE TERMINALES/BLOC DE CONNECTION
THM. - THERMAL CIRCUIT BREAKER/INTERRUPTOR TERMICO/PROTECTEUR THERMIQUE
FN - FAN/VENTILADOR/VENTILATEUR
B.X. - ARMORED CABLE/TUBO FLEXIBLE/CABLE ARME

COLOR CODE/CODIGOS DE COLOR/CODE DE COULEUR

G. - GREEN/VERDE/VERT
W. - WHITE/BLANCO/BLANC
R. - RED/ROJO/ROUGE
O. - ORANGE/NARANJA/ORANGE
Y. - YELLOW/AMARILLO/JAUNE
BR. - BROWN/CAFE/BRUN
BL. - BLUE/AZUL/BLEU
BK. - BLACK/NEGRO/NOIR
PK. - PINK/ROSA/ROSE
T. - TAN/CAFE CLARO/BEIGE

WIRE ALAMBRE FIL	GAUGE MEDIDA CALIBRE	TEMP. °C	CSA	UL
1	18	125	CL1251	3173
2	16	125	CL1251	3173
3	14	125	CL1251	3173
4	12	125	CL1251	3173
5	18	150	EXL-150	3321
6	16	150	EXL-150	3321
7	14	150	EXL-150	3321
8	12	150	EXL-150	3321
9	10	150	EXL-150	3321
10	18	200	SEW-1	3122
11	16	200	SEW-1	3122
21	22	125	CL-1252	3266
22	22	150		10109
32	8	125	CL-1251	3173
33	10	125	CL-1251	3173
34	16	200		3512
35	18	200		3512

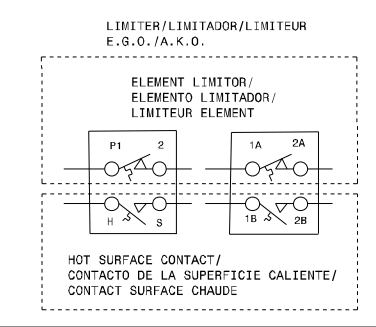

CAUTION: DISCONNECT POWER BEFORE SERVICING UNIT.
ATENCIÓN: CORTAR LA CORRIENTE ANTES DE REALIZAR EL MANTENIMIENTO DEL ELECTRODOMESTICO.
ATTENTION: COUPEZ L'ALIMENTATION AVANT D'EFFECTUER LA REPARATION.

318046831 REV:F