

OVEN CIRCUIT

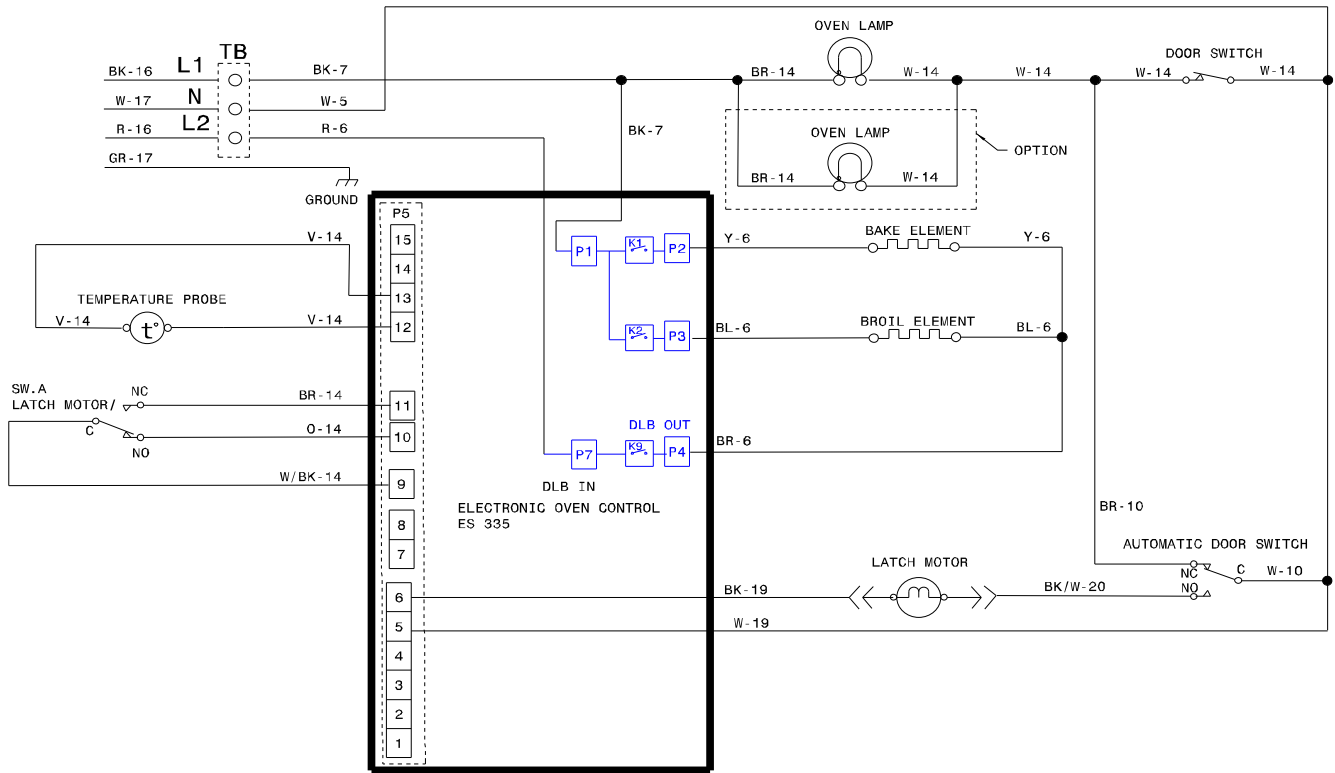

SURFACE - ELEMENT - CIRCUIT COIL

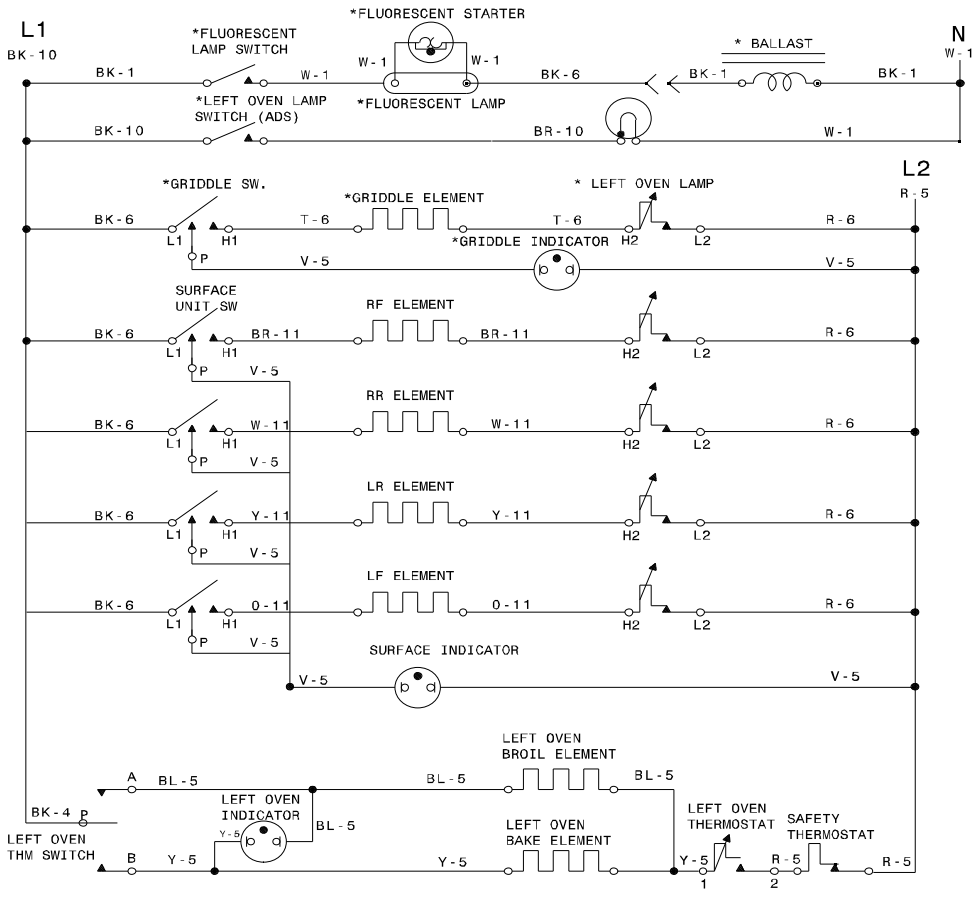

COLORS

BK. - BLACK
G. - GREEN
W. - WHITE
R. - RED
O. - ORANGE
Y. - YELLOW
BR. - BROWN
BL. - BLUE
V. VIOLET

ELEMENT LIMITER

LIMITER/
E. G. O. / A. K. O. CERAMASPEED/EIKA

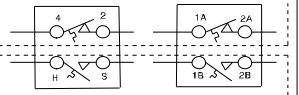

CODE	GAUGE	TEMP. °C	CSA	UL
1	18	125	CL1251	3173
2	16	125	CL1251	3173
3	14	125	CL1251	3173
4	12	125	CL1251	3173
5	18	150	EXL-150	3321
6	16	150	EXL-150	3321
7	14	150	EXL-150	3321
8	12	150	EXL-150	3321
9	10	150	EXL-150	3321
10	18	200	SEW-1	3122
11	16	200	SEW-1	3122
12	12	250		3252
13	16	250		3252
14	20	150	EXL-150	3321
15	8	150	EXL-150	3321
16	8	60		
17	10	60		
18	10	200	SEW-1	3122
19	20	125	CL1251	3173
20	20	200	SEW-1	3122

CAUTION: DISCONNECT POWER BEFORE SERVICING UNIT.
 LABEL ALL WIRES PRIOR TO DISCONNECTION WHEN SERVICING CONTROLS.
 WIRINGS ERRORS CAN CAUSE IMPROPER AND DANGEROUS OPERATION.
 VERIFY PROPER OPERATION AFTER SERVICING.

318045339 REV. B