



GAS RANGE
Use & Care Guide

COCINA (ESTUFA) DE GAS
Guía para el Uso y Cuidado

Models, Modelos **362.7242***, **7342***

* = color number, número de color

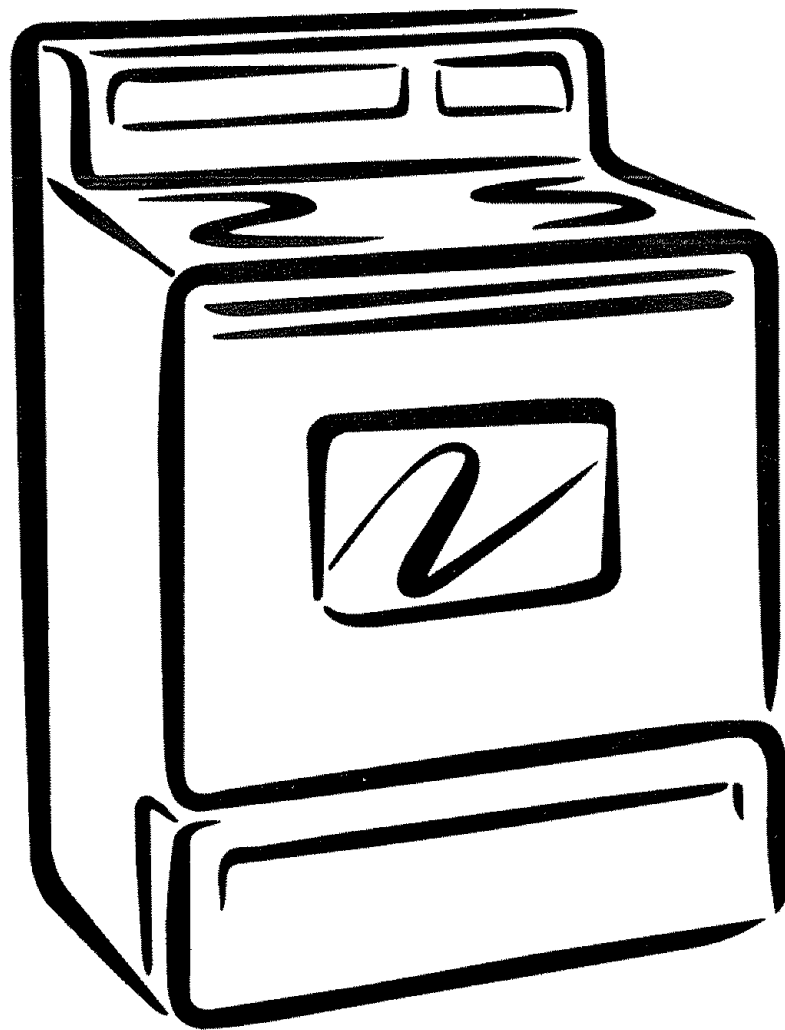

ENGLISH

ESPAÑOL

TABLE OF CONTENTS

Safety Instructions

Anti-Tip Device	2, 3, 29, 36
Important Safety Instructions	2-5, 28

Operation

Baking	13, 14
Broiling/Broiling Guide	18, 19
Clock	11
Features of Your Range	6, 7
Griddle	10
Roasting, Roasting Guide	16, 17
Surface Cooking	8-10

Care & Maintenance

Before You Call for Service	37
Care and Cleaning	20-25
Consumer Services	80
Master Protection Agreements	38

Care & Maintenance (cont.)

Repair Services	80
Thermostat Adjustment	15
Warranty	38

Installation Instructions

Air Adjustment	35
Anti-Tip Device	29, 36
Connect the Range to Gas	30, 31
Dimensions & Clearances	27
Electrical Connections	31, 32
For Your Safety	26, 28, 29
LP	36

Serviceback cover

En Español

Instrucciones en español	39
--------------------------	----

PRODUCT RECORD

For your convenience and future reference, please write down your model and serial numbers in the space provided. The model number and serial number of your gas range can be found on a plate fastened to the front frame behind the broiler compartment.

MODEL NUMBER:

SERIAL NUMBER:

IMPORTANT SAFETY INSTRUCTIONS



▲ WARNING

- ALL RANGES CAN TIP
- INJURY TO PERSONS COULD RESULT
- INSTALL ANTI-TIP DEVICES PACKED WITH RANGE
- SEE INSTALLATION INSTRUCTIONS

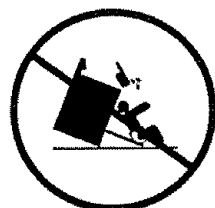

▲ WARNING: If the information in this manual is not followed exactly, a fire or explosion may result causing property damage, personal injury or death.

— Do not store or use gasoline or other flammable vapors and liquids in the vicinity of this or any other appliance.

— WHAT TO DO IF YOU SMELL GAS

- Do not try to light any appliance.
- Do not touch any electrical switch; do not use any phone in your building.
- Immediately call your gas supplier from a neighbor's phone. Follow the gas supplier's instructions.
- If you cannot reach your gas supplier, call the fire department.

— Installation and service must be performed by a qualified installer, service agency or the gas supplier.



IMPORTANT SAFETY INSTRUCTIONS

Read all instructions before using this appliance.

IMPORTANT SAFETY NOTICE

- The California Safe Drinking Water and Toxic Enforcement Act requires the Governor of California to publish a list of substances known to the state to cause cancer, birth defects or other reproductive harm, and requires businesses to warn customers of potential exposure to such substances.

Gas appliances cause minor exposure to four of these substances, namely benzene, carbon monoxide, formaldehyde and soot, caused primarily by the incomplete combustion of natural gas or LP fuels. Properly adjusted burners, indicated by a bluish rather than a yellow flame, will minimize incomplete combustion. Exposure to these substances can be minimized further by venting with an open window or using a ventilation fan or hood.

When You Get Your Range

- Have the installer show you the location of the range gas shut-off valve and how to shut it off if necessary.
- Have your range installed and properly grounded by a qualified installer in accordance with the Installation Instructions. Any adjustment and service should be performed only by qualified gas range installers or service technicians.
- Plug your range into a 120-volt grounded outlet only. Do not remove the round grounding prong from the plug. If in doubt about the grounding of the home electrical system, it is your personal responsibility and obligation to have an ungrounded outlet replaced with a properly grounded, three-prong outlet in accordance with the National Electrical Code. Do not use an extension cord with this appliance.
- Do not attempt to repair or replace any part of your range unless it is specifically recommended in this manual. All other servicing should be referred to a qualified technician.
- Be sure all packing materials are removed from the range before operating it to prevent fire or smoke damage, should the packing material ignite.
- Locate the range out of kitchen traffic path and out of drafty locations to prevent poor air circulation.

- After prolonged use of a range, high floor temperatures may result and many floor coverings will not withstand this kind of use. Never install the range over vinyl tile or linoleum that cannot withstand such type of use. Never install it directly over interior kitchen carpeting.
- Be sure your range is correctly adjusted by a qualified installer for the type of gas (natural or LP) that is to be used. Your range can be converted for use with either type of gas. See the Installation Instructions.

⚠ WARNING: These adjustments must be made by a qualified service technician in accordance with the manufacturer's instructions and all codes and requirements of the authority having jurisdiction. Failure to follow these instructions could result in serious injury or property damage. The qualified agency performing this work assumes responsibility for the conversion.

⚠ WARNING



All ranges can tip and injury could result. To prevent accidental tipping of the range, attach it to the wall and floor by installing the Anti-Tip device supplied.

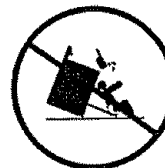

If the Anti-Tip device supplied with the range does not fit this application, use the universal Anti-Tip device WB2X7909. Call 1-800-4-MY-HOME®.

To check if the device is installed and engaged properly, open the broiler compartment and inspect the rear leveling leg. Make sure it fits securely in the slot.

If you pull the range out from the wall for any reason, make sure the device is properly engaged when you push the range back against the wall. If it is not, there is a possible risk of the range tipping over and causing injury if you or a child stand, sit or lean on an open door. Please refer to the Anti-Tip device information in this manual. Failure to take this precaution could result in tipping of the range and injury.

Using Your Range

- Do not leave children alone or unattended where a range is hot or in operation. They could be seriously burned.
- Large scratches or impacts to glass doors can lead to broken or shattered glass.

• CAUTION: ITEMS OF INTEREST TO CHILDREN SHOULD NOT BE STORED IN CABINETS ABOVE A RANGE OR ON THE BACKSPASH OF A RANGE—CHILDREN CLIMBING ON THE RANGE TO REACH ITEMS COULD BE SERIOUSLY INJURED.

IMPORTANT SAFETY INSTRUCTIONS

- **Do not allow anyone to climb, stand or hang on the door, broiler compartment or cooktop.** They could damage the range and even tip it over, causing severe personal injury.
 - **Let the burner grates and other surfaces cool before touching them or leaving them where children can reach them.**
 - **Never wear loose fitting or hanging garments while using the appliance.** Be careful when reaching for items stored in cabinets over the cooktop. Flammable material could be ignited if brought in contact with flames or hot oven surfaces and may cause severe burns.
 - **Do not use water on grease fires. Never pick up a flaming pan.** Turn the controls off. Smother a flaming pan on a surface unit by covering the pan completely with a well-fitting lid, cookie sheet or flat tray. Use a multi-purpose dry chemical or foam-type fire extinguisher.
 - Flaming grease outside a pan can be put out by covering it with baking soda or, if available, by using a multi-purpose dry chemical or foam-type fire extinguisher.
 - Flame in the oven can be smothered completely by closing the oven door and turning the oven off or by using a multi-purpose dry chemical or foam-type fire extinguisher.
 - **Do not store flammable materials in an oven, a range broiler or near a cooktop.**
 - **Do not store or use combustible materials, gasoline or other flammable vapors and liquids in the vicinity of this or any other appliance.**
 - **Do not let cooking grease or other flammable materials accumulate in or near the range.**
 - **Cook meat and poultry thoroughly**—meat to at least an INTERNAL temperature of 160°F and poultry to at least an INTERNAL temperature of 180°F. Cooking to these temperatures usually protects against foodborne illness.
 - **For your safety, never use your appliance for warming or heating the room.**
 - **Use only dry pot holders**—moist or damp pot holders on hot surfaces may result in burns from steam.
 - **Do not let pot holders come near open flames when lifting cookware.** Do not use a towel or other bulky cloth in place of a pot holder.
 - **To minimize the possibility of burns,** ignition of flammable materials and spillage, turn cookware handles toward the side or back of the range without letting them extend over adjacent burners.
 - **Always turn the surface burners to OFF before removing cookware or the griddle.**
 - **Carefully watch foods being fried at a high flame setting.**
 - **Never block the vents (air openings) of the range.** They provide the air inlet and outlet that are necessary for the range to operate properly with correct combustion. Air openings are located at the rear of the cooktop, at the top and bottom of the oven door, and at the bottom of the range under the broiler compartment.
- Do not use a wok if the wok has a round metal ring that is placed over the burner grate to support the wok.** This ring acts as a heat trap, which may damage the burner grate and burner head. Also, it may cause the burner to work improperly. This may cause a carbon monoxide level above that allowed by standards, resulting in a health hazard.
- **Foods for frying should be as dry as possible.** Frost on frozen foods or moisture on fresh foods can cause hot fat to bubble up and over the sides of the pan.
 - **Use the least possible amount of fat for effective shallow or deep fat frying.** Filling the pan too full of fat can cause spillovers when food is added.
 - **If a combination of oils or fats will be used in frying,** stir together before heating or as fats melt slowly.
 - **Always heat fat slowly and watch as it heats.**
 - **Use a deep-fat thermometer whenever possible** to prevent overheating fat beyond the smoking point.
 - **Never try to move a pan of hot fat, especially a deep fat fryer.** Wait until the fat is cool.
 - **Use proper pan size.** Avoid pans that are unstable or easily tipped. Select cookware having flat bottoms large enough to properly contain food and avoid boilovers and spillovers and large enough to cover burner grates. This will both save cleaning time and prevent hazardous accumulations of food, since heavy spattering or spillovers left on the range can ignite. Use pans with handles that can be easily grasped and will remain cool.
 - **Do not lift the cooktop.** Lifting the cooktop can lead to damage and improper operation of the range.

Surface Cooking

- **Always use the LITE position when igniting the top burners and make sure the burners have ignited.**
- **Never leave the surface burners unattended at high flame settings.** Boilovers cause smoking and greasy spillovers that may catch on fire.
- **Adjust the top burner flame size so it does not extend beyond the edge of the cookware.** Excessive flame is hazardous.

IMPORTANT SAFETY INSTRUCTIONS

- When using glass cookware, make sure it is designed for top-of-range cooking.
- Keep all plastics away from the top burners.

- Do not leave plastic items on the cooktop—they may melt if left too close to the vent.

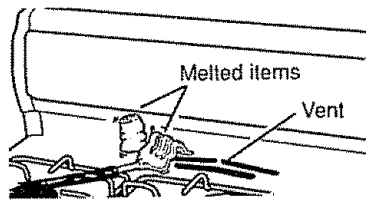

Vent appearance and location vary.

- Do not leave any items on the cooktop. The hot air from the vent may ignite flammable items and will increase pressure in closed containers, which may cause them to burst.
- To avoid the possibility of a burn, always be certain that the controls for all burners are at the OFF position and all grates are cool before attempting to remove them.
- When flaming foods are under the hood, turn the fan OFF. The fan, if operating, may spread the flames.
- If the range is located near a window, do not hang long curtains that could blow over the top burners and create a fire hazard.
- If you smell gas, turn off the gas to the range and call a qualified service technician. Never use an open flame to locate a leak.
- Never leave the kitchen while using the griddle.
- Do not use aluminum foil to line the griddle. Misuse could result in a fire hazard.

Baking, Broiling and Roasting

- Do not use the oven for a storage area. Items stored in the oven can ignite.
- Keep the oven free from grease buildup.
- Place the oven shelves in the desired position while the oven is cool.
- Stand away from the range when opening the door of a hot oven. The hot air and steam that escape can cause burns to hands, face and eyes.
- Pulling out the shelf to the shelf-stop is a convenience in lifting heavy foods. It is also a precaution against burns that could result from touching hot surfaces of the door or oven walls. The lowest position is not designed to slide.
- Do not heat unopened food containers. Pressure could build up and the container could burst, causing an injury.

- Do not use aluminum foil anywhere in the oven except as described in this manual. Misuse could result in a fire hazard or damage to the range.
- Never use aluminum foil to line the oven bottom. Improper use of foil could start a fire and result in high carbon monoxide.
- When using cooking or roasting bags in the oven, follow the manufacturer's directions.
- Use only glass cookware that is recommended for use in gas ovens.
- Always remove broiler pan from the range as soon as you finish broiling. Grease left in the pan can catch on fire if oven is used without removing the grease from the broiler pan.
- When broiling, if meat is too close to the flame, the fat may ignite. Trim excess fat to prevent excessive flare-ups.
- Make sure the broiler pan is in place correctly to reduce the possibility of grease fires.
- If you should have a grease fire in the broiler pan, turn the oven off and keep the broiler compartment and oven door closed to contain fire until it burns out.
- For safety and proper cooking performance, always bake and broil with the oven door closed.

Cleaning Your Range

- Clean only parts listed in this Use and Care Guide.
- Keep the range clean and free of accumulations of grease or spillovers, which may ignite.
- Do not lift the cooktop. Lifting the cooktop can lead to damage and improper operation of the range.

SAVE THESE INSTRUCTIONS

FEATURES OF YOUR RANGE

NOTE: Not all models have all features. Appearance of features varies.

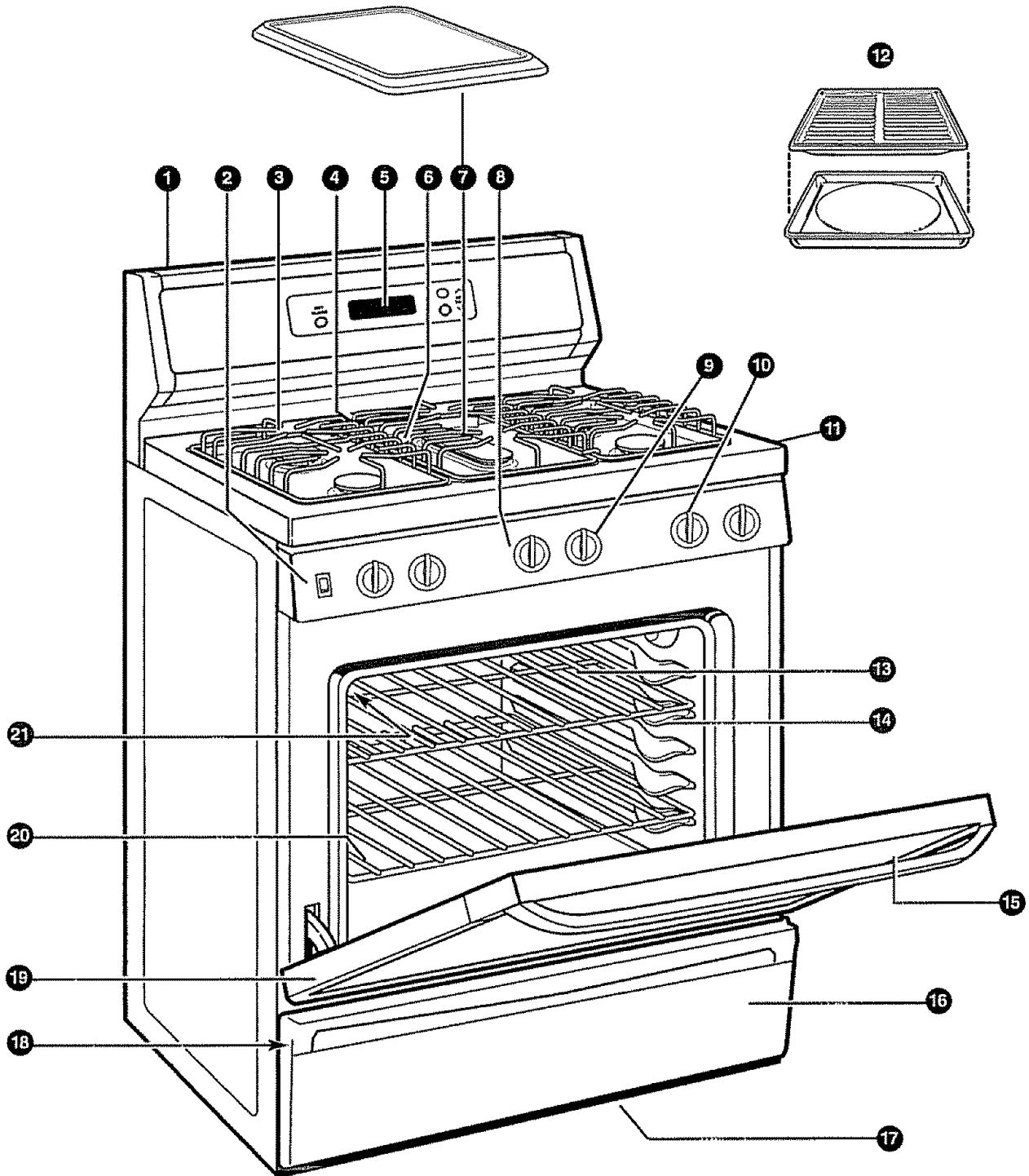

FEATURES OF YOUR RANGE

Feature Index (Not all models have all features. Appearance of features varies.)	See page
1 Backguard	—
2 Oven Light On/Off Switch	11
3 Side Surface Burners and Grates	3–5, 8, 9, 21, 22
4 Oven Vent (located on cooktop)	4, 5, 12, 23
5 Clock	11
6 Center Surface Burner Use when cooking with large oval pots/pans, round pots/pans 10" or greater in diameter or with the griddle.	3–5, 8, 21, 22
7 Griddle and Center Grate When cooking, the center grate must always be in place. To use the griddle, it must be locked onto the center grate only.	10, 20–22
8 Center/Griddle Surface Burner Control Knob	8, 10, 23
9 Oven Control	11, 13, 15–19, 23
10 Side Surface Burner Control Knobs	8, 23
11 Cooktop	4, 5, 22
12 Broiler Pan and Grid	5, 16, 18, 19, 24
13 Oven Shelves with Stop-Locks	5, 12–14, 16, 18, 24
14 Oven Shelf Supports (shelf positions for cooking are suggested in the Baking, Roasting and Broiling sections)	5, 12–14, 16 18, 19
15 Air Vent in Oven Door (located at top of the oven door)	4, 23
16 Broiler Compartment	4, 18, 19, 24
17 Air Intake	4, 23
18 Model and Serial Numbers (located on front frame of range, behind broiler compartment)	2
19 Lift-Off Oven Door	18, 19, 25
20 Oven Bottom	24, 25
21 Oven Interior Light	11, 23

USING THE COOKTOP

Surface Burner Controls

Knobs that turn the surface burners on and off are marked as to which burners they control. The two knobs on the left control the left front and left rear burners. The two knobs on the right control the right front and right rear burners. The center left knob controls the center oval burner.

Before Lighting a Burner

- Make sure all burners and caps are in place.
- Make sure all the grates (and the center griddle, if it is going to be used) are in place on the range before using any burner.

- The center oval burner is the largest in size and is for large oval pots/pans, round pots/pans 10" or greater in diameter or with the griddle.
- The side burners are all the same size and power.

To Light a Surface Burner

Make sure all surface burners are placed in their respective positions.

Push the control knob in and turn it to LITE. You will hear a little "clicking" noise—the sound of the electric spark igniting the burner.

Turn the knob to adjust the flame size. If the knob stays at LITE, it will continue to click.

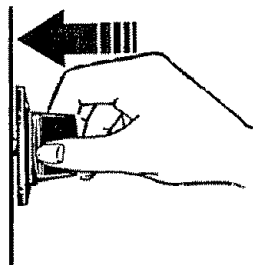

When one burner is turned to LITE, all the burners spark. Do not attempt to disassemble or clean around any burner while another burner is on. An electric shock may result, which could cause you to knock over hot cookware.

In case of a power failure, you can light the surface burners on your range with a match. Hold a lighted match to the burner, then turn the knob to the LITE position. Use extreme caution when lighting burners this way.

Surface burners in use when an electrical power failure occurs will continue to operate normally.

After Lighting a Burner

- After the burner ignites, turn the knob to adjust the flame.
- Check to be sure the burner you turned on is the one you want to use.
- Do not operate a burner for an extended period of time without cookware on the grate. The finish on the grate may chip without cookware to absorb the heat.
- Be sure the burners and grates are cool before you place your hand, a pot holder, cleaning cloths or other materials on them.

How to Select Flame Size

Watch the flame, not the knob, as you reduce heat.

When fast heating is desired, the flame size on a gas burner should match the cookware you are using.

Use only large oval pots/pans, round pots/pans 10" or greater in diameter or the griddle on the center burner.

FOR SAFE HANDLING OF COOKWARE NEVER LET THE FLAME EXTEND UP THE SIDES OF THE COOKWARE.

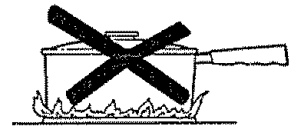

Any flame larger than the bottom of the cookware will not result in faster heating of the cookware and could be hazardous.

USING THE COOKTOP (continued)

Top-of-Range Cookware

Aluminum: Medium-weight cookware is recommended because it heats quickly and evenly. Most foods brown evenly in an aluminum skillet. Use saucepans with tight-fitting lids when cooking with minimum amounts of water.

Cast-Iron: If heated slowly, most skillets will give satisfactory results.

Enamelware: Under some conditions, the enamel of some cookware may melt. Follow cookware manufacturer's recommendations for cooking methods.

Glass: There are two types of glass cookware—those for oven use only and those for top-of-range cooking (saucepans, coffee and teapots). Glass conducts heat very slowly.

Heatproof Glass Ceramic: Can be used for either surface or oven cooking. It conducts heat very slowly and cools very slowly. Check cookware manufacturer's directions to be sure it can be used on gas ranges.

Stainless Steel: This metal alone has poor heating properties and is usually combined with copper, aluminum or other metals for improved heat distribution. Combination metal skillets usually work satisfactorily if they are used with medium heat as the manufacturer recommends.

Wok

We recommend that you use a 14-inch or smaller flat-bottomed wok. Make sure the wok bottom sits flat on the grate. Only a flat-bottomed wok should be used. They are available at your local retail store.



Do not use a flat-bottomed wok on a support ring.

Placing the ring over the burner grate may cause the burner to work improperly, resulting in carbon monoxide levels above allowable standards. This could be dangerous to your health.

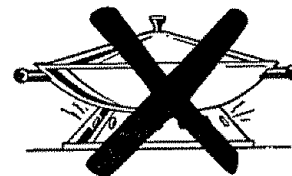

Stove Top Grills

Do not use stove top grills on your gas burners. If you use the stove top grill on the gas burner, it will cause incomplete combustion and can result in exposure to carbon monoxide levels above allowable standards. This can be hazardous to your health.

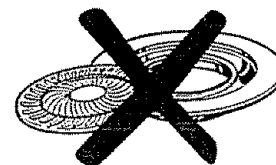

Griddle

Use only the griddle shipped with your range. It is specifically designed to operate with the center surface burner of your range. See the griddle information in this Use & Care Guide for proper use.

USING THE COOKTOP (continued)

Griddle

Your non-stick coated griddle provides an extra-large cooking surface for meats, pancakes or other food usually prepared in a frying pan or skillet.



NOTE: Your griddle will discolor over time as it becomes seasoned with use.

How to Insert the Griddle

CAUTION: Place and remove the griddle only when all grates and griddle are cool and all surface units are turned OFF.

The griddle can only be used with the center burner and must be locked into place on the center grate.

Place the "U" locks on the underside of the griddle over the center fingers of the center grate.

Move the griddle back-and-forth to make sure it is locked in place.

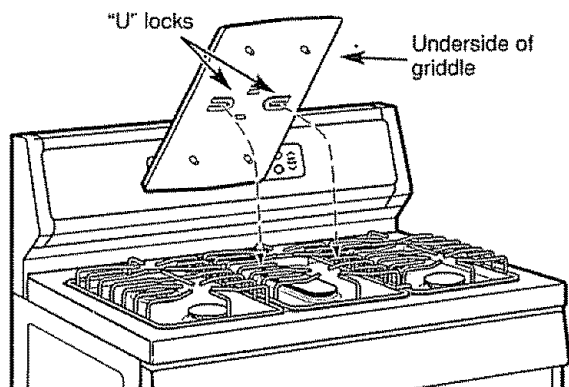

Place the "U" locks onto the center fingers on the center grate.

Using the Griddle

Most griddled foods require cooking on a preheated surface. Preheat griddle according to the guide below, then switch to the desired cook setting.

Type of Food	Preheat Conditions	Maximum Quantity Recommended
Warming Tortillas	none	7 stacked
Pancakes	High for 3 minutes	6
Hamburgers	Medium for 5 minutes	4 – flattened out
Fried Eggs	Medium for 5 minutes	4
Bacon	High for 5 minutes	4
Breakfast Sausage Links	None—no oil	13
Hot Sandwiches (such as Grilled Cheese)	High for 6 minutes then Medium for 4 minutes	4

IMPORTANT NOTES:

- Avoid cooking extremely greasy foods and be careful of grease spill-over while cooking.
- Do not use oil on the griddle for extended lengths of time. Permanent staining and/or craze lines on the surface could result.
- Do not cook milk products (such as french toast) on the griddle. Permanent staining and/or craze lines on the surface could result.
- Never place or store any items on the griddle, even when it is not in use. The griddle can become heated when using the surrounding burners.
- **Do not overheat the griddle.** Leaving the griddle burner on at HI for an extended amount of time without food can damage the non-stick coating.

USING THE OVEN

Before Using Your Oven Oven Shelves

To avoid possible burns, place the shelves in the desired position before you turn the oven on.

The shelves have stop-locks so, when placed correctly on the shelf supports (A through E), they will stop before coming completely out; they also will not tilt.

When placing and removing cookware, pull the shelf out to the bump on the shelf support.

To remove a shelf, pull it toward you, tilt the front end up and pull it out.

To replace, place the end of the shelf (stop-locks) on the support, tilt up the front and push the shelf in.

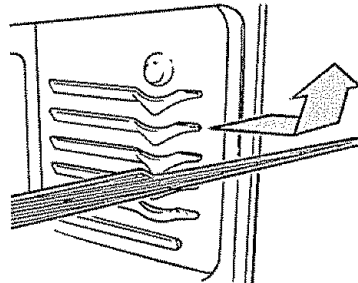
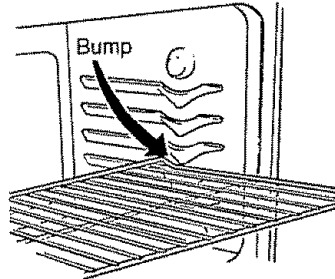

NOTE: The shelf is not designed to slide out at the special low (R) shelf position.

Power Outage

CAUTION: Do not make any attempt to operate the electric ignition oven during an electrical power failure. The oven or broiler cannot be lit during a power failure. Gas will not flow unless the glow bar is hot.

If the oven is in use when a power failure occurs, the oven burner shuts off and cannot be re-lit until power is restored. This is because the flow of gas is automatically stopped and will not resume when power is restored until the glow bar has reached operating temperature.

To Set the Clock

NOTE: When you first plug in the range or after a power failure, the entire Clock display will light up.

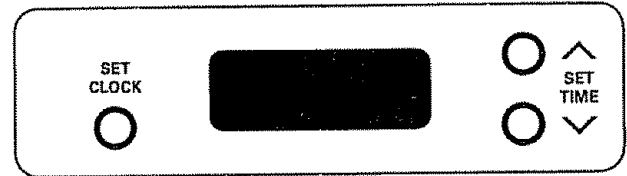

1. Press the SET CLOCK button.



2. Press and hold the + or – button and the time of day will change 10 minutes at a time. To change the time by single minutes, give the buttons short taps.

3. Press the SET CLOCK button to start the clock.

Oven Control

Your oven is controlled by a single OVEN CONTROL knob.

It will normally take 30–90 seconds before the flame comes on. After the oven reaches the selected temperature, the oven burner repeatedly cycles—off completely, then on with a full flame—to maintain the selected temperature.

Oven Moisture

As your oven heats up, the temperature change of the air in the oven may cause water droplets to form on the door glass. These droplets are harmless and will evaporate as the oven continues to heat up.

Oven Light

Use the switch on the lower control panel to turn the light on or off.

USING THE OVEN (continued)

Shelf Positions

The oven has five shelf supports for baking and roasting as shown in this illustration—A (bottom), B, C, D and E (top). It also has a special low shelf position (R) for roasting extra large items, such as a large turkey—the shelf is not designed to slide out at this position. The shelf positions for cooking are suggested in the Baking and Roasting sections.

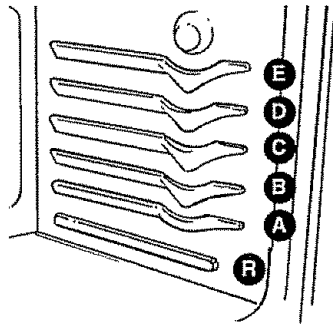

Oven Vents

The oven is vented through duct openings at the rear of the range. Do not block these openings when cooking in the oven—it is important that the flow of hot air from the oven and fresh air to the oven burners be uninterrupted.

- **Avoid touching the vent openings and nearby surfaces during oven or broiler operation.** They may become hot.

- **Do not leave plastic or flammable items on the cooktop—** they may melt or ignite if left too close to the vent.

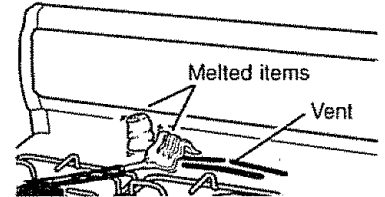

Vent appearance and location vary.

- **Handles of pots and pans on the cooktop may become hot if left too close to the vent.**
- **Metal items will become very hot if they are left on the cooktop and could cause burns.**
- **Do not leave closed containers on the cooktop.** The pressure in closed containers may increase, which may cause them to burst.

USING THE OVEN (continued)

Baking

Your oven temperature is controlled using the latest technology in oven control systems. It is recommended that you operate the oven for a number of weeks to become familiar with your new oven's performance. If you think an adjustment is necessary, see the Adjust the Oven Thermostat section.

NOTE: Your oven is not designed for open-door cooking.

How to Set Your Range for Baking

To avoid possible burns, place the shelves in the correct position before you turn the oven on.

1. Close the oven door. Turn the OVEN TEMP knob to the desired temperature.
2. Check the food for doneness at the minimum time on the recipe. Cook longer if necessary.
3. Turn the OVEN TEMP knob to OFF and then remove food.

Oven Shelves

Arrange the oven shelf or shelves in the desired locations while the oven is cool. The correct shelf position depends on the kind of food and the browning desired. As a general rule, place most foods in the middle of the oven, on either shelf position B or C. See the following chart for suggested shelf positions.

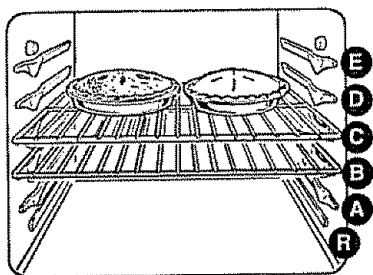

Type of Food	Shelf Position
Angel food cake	B
Biscuits or muffins	B or C
Cookies or cupcakes	B or C
Brownies	B or C
Layer cakes	C
Bundt or pound cakes	B
Pies or pie shells	B or C
Frozen pies	A (on cookie sheet)
Casseroles	B or C
Roasting	B or R

Preheating

Preheat the oven if the recipe calls for it. Preheat means bringing the oven up to the specified temperature before putting the food in the oven. To preheat, set the oven at the correct temperature—selecting a higher temperature does not shorten preheat time.

Preheating is necessary for good results when baking cakes, cookies, pastry and breads. For most casseroles and roasts, preheating is not necessary. Preheat 10 minutes. After the oven is preheated place the food in the oven as quickly as possible to prevent heat from escaping.

Baking Pans

Use the proper baking pan. The type of finish on the pan determines the amount of browning that will occur.

- Dark, rough or dull pans absorb heat resulting in a browner, crisper crust. Use this type for pies.
- Shiny, bright and smooth pans reflect heat, resulting in a lighter, more delicate browning. Cakes and cookies require this type of pan.
- Glass baking dishes also absorb heat. When baking in glass baking dishes, the temperature may need to be reduced by 25°F (13°C).
- If you are using dark non-stick pans, you may find that you need to reduce the oven temperature 25°F (13°C) to prevent over-browning.

Pan Placement

For even cooking and proper browning, there must be enough room for air circulation in the oven. Baking results will be better if baking pans are centered as much as possible rather than being placed to the front or to the back of the oven.

Pans should not touch each other or the walls of the oven. Allow 1- to 1½-inch (2.5- to 4-cm) space between pans as well as from the back of the oven, the door and the sides. If you need to use two shelves, stagger the pans so one is not directly above the other.

Baking

(continued)

Aluminum Foil

Never cover the oven bottom with aluminum foil.

Never entirely cover a shelf with aluminum foil.

This will disturb the heat circulation and result in poor baking. Aluminum foil may also be used to catch a spillover. To do so, place a small sheet of foil on a lower shelf several inches below the food.

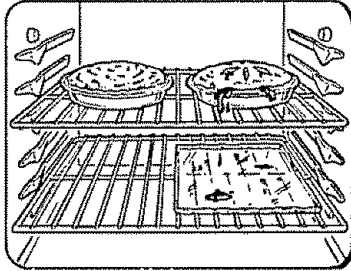

Don't Peek

Set the timer for the estimated cooking time and do not open the door to look at your food. Most recipes provide minimum and maximum baking times such as "bake 30–40 minutes."

DO NOT open the door to check until the minimum time. Opening the oven door frequently during cooking allows heat to escape and makes baking times longer. Your baking results may also be affected.

Adjust the Oven Thermostat— Do It Yourself!

You may feel that your new oven cooks differently than the one it replaced. We recommend that you use your new oven for a few weeks to become more familiar with it, following the times given in your recipes as a guide.

If you think your new oven is cooking too hot or too cold, you can adjust the thermostat yourself. If you think it is too hot, adjust the thermostat to make it cooler. If you think it is too cool, adjust the thermostat to make it hotter.

We do not recommend the use of thermometers, such as those found in grocery stores, to check the temperature setting of your new oven. These thermometers may vary 20–40°F (11–22°C).

To Adjust the Thermostat:

Pull the OVEN CONTROL knob off the range and look at the back side.

To make adjustment, loosen (approximately one turn), but do not completely remove, the top screw on the back of the knob. With the back of the knob facing you, hold the outer edge of the knob with one hand and turn the front of the knob with the other hand.

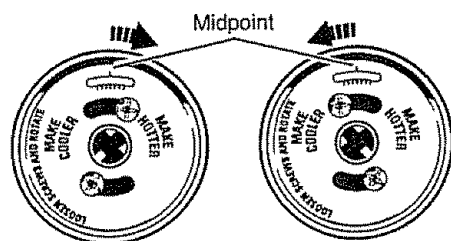

(appearance may vary)

To raise the oven temperature, move the top screw toward the right. You'll hear a click for each notch you move the knob. **To lower the temperature**, move the top screw toward the left. Each click will change the oven temperature approximately 10°F (6°C). Available thermostat setting range is 60°F (33°C). [Plus or minus 30°F (16°C) from the factory set midpoint.]

We suggest that you make the adjustment one click from the original setting and check oven performance before making any additional adjustments.

After the adjustment is made, retighten screws so they are snug, but be careful not to overtighten. Reinstall knob on range and check performance.

The Type of Margarine Will Affect Baking Performance

Most recipes for baking have been developed using high fat products such as butter or margarine (80% fat). If you decrease the fat, the recipe may not give the same results as with a higher fat product.

Recipe failure can result if cakes, pies, pastries, cookies or candies are made with low fat spreads. The lower the fat content of a spread product, the more noticeable these differences become.

Federal standards require products labeled "margarine" to contain at least 80% fat by weight. Low fat spreads, on the other hand, contain less fat and more water. The high moisture content of these spreads affects the texture and flavor of baked goods. For best results with your old favorite recipes, use margarine, butter or stick spreads containing at least 70% vegetable oil.

Roasting

Roasting is cooking by dry heat. Tender meat or poultry can be roasted uncovered in your oven. Roasting temperatures, which should be low and steady, keep spattering to a minimum.

The oven has a special low shelf position (R) just above the oven bottom. Use it when extra cooking space is needed, for example, when roasting a large turkey. The shelf is not designed to slide out at this position.

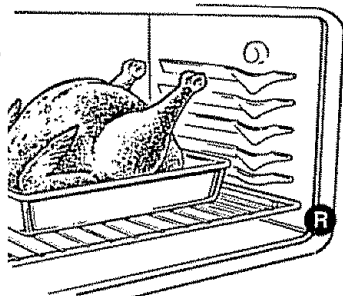

Roasting is really a baking procedure used for meats. Therefore, the oven controls are set for Baking. (You may hear a slight clicking sound indicating the oven is working properly.)

Most meats continue to cook slightly while standing after being removed from the oven. Recommended standing time for roasts is 10 to 20 minutes. This allows the roasts to firm up and makes them easier to carve. The internal temperature will rise about 5° to 10°F (3° to 6°C). If you wish to compensate for the temperature rise, remove the roast from the oven when its internal temperature is 5° to 10°F (3° to 6°C) less than the temperature shown in the Roasting Guide.

Remember that food will continue to cook in the hot oven, even after it has been turned off, and should be removed when the desired internal temperature has been reached.

1. Position oven shelf at position B for small size roast (3 to 5 lbs. [1.3 to 2.3 kg]) and at position R for larger roasts.

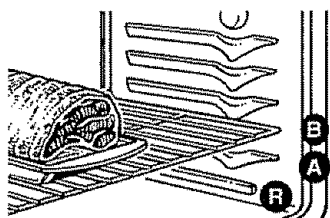

2. Check the weight of the meat. Place the meat fat-side-up or the poultry breast-side-up on roasting grid in a shallow pan. The melting fat will baste the meat. Select a pan as close to the size of the meat as possible. (The broiler pan with grid is a good pan for this.)

3. Turn the OVEN TEMP knob to the desired temperature (you may hear a slight clicking sound, indicating the oven is working properly). See the Roasting Guide for temperatures and approximate cooking times.
4. When roasting is finished, turn the OVEN TEMP knob to OFF and then remove the food from the oven.

Dual Shelf Cooking

This allows more than one food to be cooked at the same time. For example: While roasting a 20-lb. (10 kg) turkey on shelf position R, a second shelf (if so equipped) may be added on position D so that an additional food such as scalloped potatoes can be cooked at the same time. Foods cooked with the turkey should be added toward the end of the time allowed for the turkey. For example, potatoes which cook for 1 hour should be added to the oven 1 hour before the end of cooking time for the turkey.

Use of Aluminum Foil

Never cover the oven bottom with aluminum foil.

Never entirely cover a shelf with aluminum foil. This will disturb the heat circulation and result in poor baking.

Aluminum foil may also be used to catch a spillover. To do so, place a small sheet of foil on a lower shelf several inches below the food.

Frozen Roasts

Frozen roasts of beef, pork, lamb, etc., can be started without thawing, but allow 15 to 25 minutes per pound (450 grams) additional time (15 minutes per pound for roasts under 5 pounds [2.3 kg], more time for larger roasts).

Make sure poultry is thawed before roasting. Unthawed poultry often does not cook evenly. Some commercially frozen poultry can be cooked successfully without thawing. Follow the directions given on the package label.

USING THE OVEN (continued)

Roasting Guide

Type	Oven Temperature	Doneness	Approximate Roasting Time in Minutes per Pound		Internal Temperature
Meat			3 to 5 lbs. (1.4 to 2.3 kg)	6 to 8 lbs. (2.7 to 3.6 kg)	
Tender cuts; rib, high quality sirloin tip, rump or top round*	325°F (163°C)	Rare: Medium: Well Done:	24–35 35–39 39–45	18–25 25–31 31–33	140–150°F (60–66°C)† 150–160°F (66–71°C) 170–185°F (77–85°C)
Lamb leg or bone-in shoulder*	325°F (163°C)	Rare: Medium: Well Done:	21–25 25–30 30–35	20–23 24–28 28–33	140–150°F (60–66°C)† 150–160°F (66–71°C) 170–185°F (77–85°C)
Veal shoulder, leg or loin*	325°F (163°C)	Well Done:	35–45	30–40	170–180°F (77–82°C)
Pork loin, rib or shoulder*	325°F (163°C)	Well Done:	35–45	30–40	170–180°F (77–82°C)
Ham, precooked	325°F (163°C)	To Warm:	18–23 minutes per pound (450 grams) any weight		115–125°F (46–52°C)
Poultry			3 to 5 lbs. (1.4 to 2.3 kg)	Over 5 lbs. (2.3 kg)	
Chicken or Duck Chicken pieces	325°F (163°C) 350°F (177°C)	Well Done: Well Done:	35–40 35–40	30–35	185–190°F (85–88°C) 185–190°F (85–88°C)
Turkey	325°F (163°C)	Well Done:	10 to 15 lbs. (4.5 to 6.8 kg) 16–22	Over 15 lbs. (6.8 kg) 12–19	In thigh: 185–190°F (85–88°C)

* For boneless rolled roasts over 6" (15 cm) thick, add 5 to 10 minutes per pound (450 grams) to times given above.

† The U.S. Department of Agriculture says, "Rare beef is popular, but you should know that cooking it to only 140°F (60°C) means some food poisoning organisms may survive." (Source: Safe Food Book. Your Kitchen Guide. USDA Rev. June 1985.)

USING THE OVEN (continued)

Broiling

Broiling is cooking food by direct heat from above the food. Your range has a convenient broiler compartment below the oven for broiling. It also has a specially designed broiler pan and grid that allows the dripping fat to drain away from the high heat of the gas flame.

It is recommended that meat be cooked to at least an INTERNAL temperature of 160°F (71°C) and poultry to at least an INTERNAL temperature of 180°F (82°C). Cooking to these temperatures usually protects against foodborne illness.

Distance from the heat source may be changed by positioning the broiler pan and grid on one of the three shelf positions in the broiler compartment—A (bottom of broiler compartment), B (middle) and C (top).

Most fish and tender cuts of meat can be broiled. Follow these directions to keep spattering and smoking to a minimum.

The oven door and broiler compartment door must be closed during broiling.

Turn most foods once during cooking (the exception is thin fillets of fish; oil one side, place that side down on the broiler grid and cook without turning until done). Time the food for about one-half the total cooking time, turn the food, then continue to cook to the preferred doneness.

How to Broil

1. The broiler compartment does not need to be preheated for broiling.
2. If the meat has fat or gristle around the edge, cut vertical slashes through both about 2" (5 cm) apart, but do not cut into meat. If desired the fat may be trimmed, leaving a layer about 1/8" (3 mm) thick.
3. Arrange the food on the grid and position the broiler pan on the appropriate shelf in the broiler compartment. Placing the food closer to flame sears the exterior and increases the surface browning of food, but also increases spattering and the possibility of fats and meat juices igniting.
4. Close the broiler compartment and turn the OVEN TEMP knob to BROIL.
5. When broiling is finished, turn the OVEN TEMP knob to OFF. Remove the broiler pan from the broiler compartment and serve the food immediately. Do not leave a soiled broiler pan and grid inside the range.

Use of Aluminum Foil

You can use aluminum foil to line your broiler pan and broiler grid. However, you must mold the foil tightly to the grid and cut slits in it just like the grid.

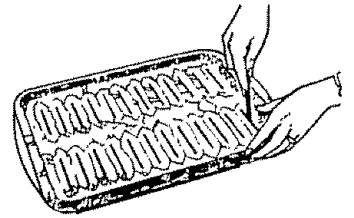

Without the slits, the foil will prevent fat and meat juices from draining to the broiler pan. The juices could become hot enough to catch on fire. If you do not cut the slits, you are frying, not broiling.

Cut slits in the foil just like the grid.

Never cover the oven bottom with aluminum foil.

USING THE OVEN (continued)

Broiling Guide

The oven door and broiler compartment must be closed during broiling.

- Always use the broiler pan and grid that comes with your range. It is designed to minimize smoking and spattering by trapping juices in the shielded lower part of the pan.
- For steaks and chops, slash fat evenly around the outside edges of the meat. To slash, cut crosswise through the outer fat surface just to the edge of the meat. Use tongs to turn the meat over to prevent piercing the meat and losing juices.

- If desired, marinate meats or chicken before broiling. Or brush with barbecue sauce last 5 to 10 minutes only.
- When arranging the food on the pan, do not let fatty edges hang over the sides because dripping fat could soil the oven.
- The broiler compartment does not need to be preheated. However, for very thin foods, or to increase browning, preheat if desired.
- Frozen steaks can be broiled by positioning the broiler pan and grid at next lowest shelf position and increasing cooking time given in this guide 1½ times per side.

The size, weight, thickness, starting temperature and your preference of doneness will affect broiling times. This guide is based on meats at refrigerator temperature.

†The U.S. Department of Agriculture says "Rare beef is popular, but you should know that cooking it to only 140°F (60°C) means some food poisoning organisms may survive." (Source: *Safe Food Book, Your Kitchen Guide*, USDA Rev. June 1985)

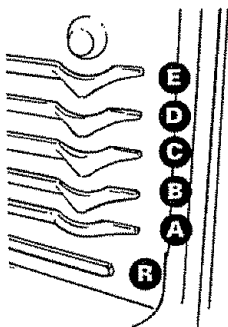

The oven has 5 shelf positions.

Food	Quantity and/or Thickness	Shelf* Position	1st Side Minutes	2nd Side Minutes	Comments	
Bacon	½ lb (227 g) (about 8 thin slices)	C	4	3	Arrange in single layer.	
Ground Beef Well Done	1 lb (450 g) (4 patties) ½"–¾" (13–19 mm) thick	C	10	7–10	Space evenly Up to 8 patties take about same time.	
Beef Steaks	1" (2.5 cm) thick (1–1½ lbs (450 g–680 g))	Rare†	9	7	Steaks less than 1" (2.5 cm) thick cook through before browning Pan frying is recommended	
		Medium	12	5–6		
		Well Done	13	8–9		
Rare† Medium Well Done	1½" (3.8 cm) thick (2–2½ lbs (907 g–1.13 kg))	C	10	6–7	Slash fat	
		C	12–15	10–12		
		B	25	16–18		
Chicken	1 whole (2–2½ lbs. [907 g–1.13 kg]), split lengthwise Bone-in, 4 bone-in breasts	B	30–35	15	Reduce times about 5 to 10 minutes per side for cut-up chicken Brush each side with melted butter. Broil with skin side down first.	
		B	25–30	10–15		
Bakery Products Bread (Toast) or Toaster Pastries English Muffins	2–4 slices 1 pkg. (2) 2, split	C	2–3	1/2–1	Space evenly. Place English muffins cut-side-up and brush with butter, if desired.	
		C	3–5			
Lobster Tails	2–4 (6–8 oz [170 g–227 g] ea)	A	13–16	Do not turn over.	Cut through back of shell and spread open Brush with melted butter before broiling and after half of broiling time.	
Fish	1 lb (450 g) fillets ¼"–½" (6–13 mm) thick	C	5	5	Handle and turn very carefully Brush with lemon butter before and during broiling, if desired Preheat broiler to increase browning.	
Ham Slices Precooked	1" (2.5 cm) thick 1/2" (13 mm) thick	B	8	8	Increase times 5 to 10 minutes per side for 1½" (3.8 cm) thick or home cured.	
		B	6	6		
Pork Chops Well Done	2 (1½" [13 mm] thick) 2 (1" [2.5 cm] thick), about 1 lb. (450 g)	B	10	4–5	Slash fat	
		B	13	9–12		
Lamb Chops Medium Well Done	2 (1" [2.5 cm] thick), about 10–12 oz (284–340 g)	B	8	4–7	Slash fat	
		B	10	10		
	Medium Well Done	2 (1½" [3.8 cm] thick), about 1 lb. (450 g)	B	10		4–6
			B	17		12–14
Wieners, similar precooked sausages, bratwurst	1 lb (450 g) pkg (10)	C	6	1–2	If desired, split sausages in half length-wise; cut into 5–6" (13–15 cm) pieces.	

*See illustration for description of shelf positions.

CARE AND CLEANING

Proper care and cleaning are important so your range will give you efficient and satisfactory service. Follow these directions carefully in caring for it to help assure safe and proper maintenance.

BE SURE ELECTRICAL POWER IS DISCONNECTED BEFORE CLEANING ANY PART OF YOUR RANGE.

Griddle

NOTE: The griddle is to be used on the center burner grate only.

Thoroughly clean the griddle of grease and food particles, using a square-edged spatula, while it is still hot.

Wipe the griddle with a dry, heavy, coarse cloth to remove any remaining residue and food particles.

Wash with hot soapy water, rinse and dry.

Once the griddle has cooled, rub the surface lightly with vegetable oil. Do not use corn oil or cooking sprays as they get sticky.

If the griddle is cleaned with anything other than a dry, heavy, coarse cloth, it will need to be reseasoned.

Never flood the hot griddle with cold water. This could cause the griddle to crack or warp.

As the griddle is used and seasoned, it may change color over time.

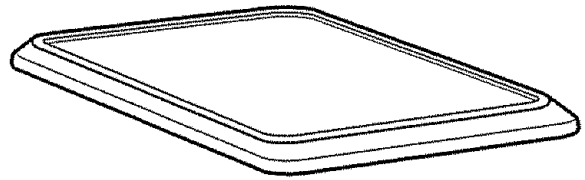

Griddle Precautions:

- If something has spilled under the griddle, it should be cleaned up as soon as possible to prevent "baked on" food soil.
- Do not allow grease to accumulate under the griddle as it can be a fire hazard. Clean under the griddle as soon as it is cool. Clean with hot soapy water.

CARE AND CLEANING

BE SURE ELECTRICAL POWER IS DISCONNECTED BEFORE CLEANING ANY PART OF YOUR RANGE.

Burner Assemblies

CAUTION: DO NOT OPERATE THE COOKTOP WITHOUT ALL BURNER PARTS AND GRATES IN PLACE.

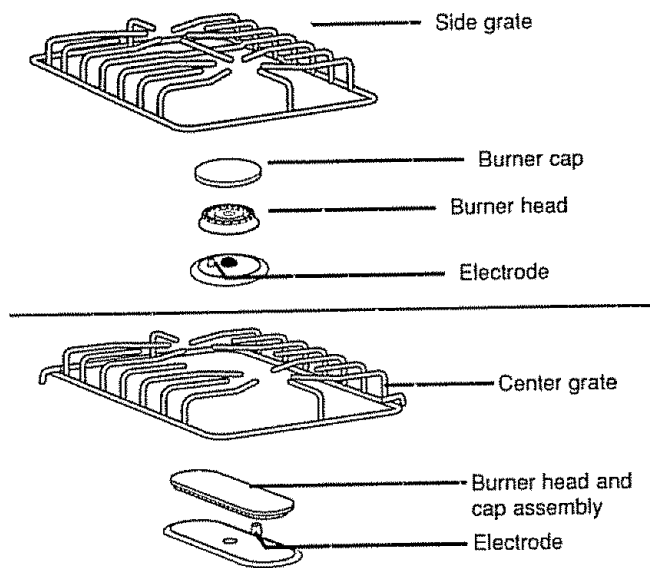

Turn all controls OFF before removing the burner parts.

The burner grates, caps and burner heads can be lifted off, making them easy to clean.

Lift off burner parts for cleaning when they are cool.

CAUTION:

The electrode of the spark igniter is exposed when the burner head is removed. When one burner is turned to LITE, all the burners spark. Do not attempt to disassemble or clean around any burner while another burner is on. An electric shock may result, which could cause you to knock over hot cookware.

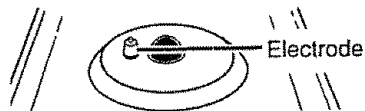

Burner Heads

For proper ignition, make sure the small hole in the section that fits over the electrode is kept open. A sewing needle or bare wire works well to unclog it.

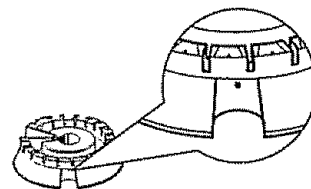

The slits in the burner heads of your range must be kept clean at all times for an even, unhampered flame.

You should clean the surface burners routinely, especially after bad spills, which could clog these openings.

To remove burned-on food, soak the burner heads in a solution of mild liquid detergent and hot water for 20–30 minutes. For more stubborn stains, use a toothbrush.

Before putting the burner head back, shake out excess water and then dry it thoroughly by setting it in a warm oven for 30 minutes.

Replace the burner heads and caps. Make sure that the heads and caps are replaced in the correct location. There is one oval (center) head and cap assembly and four medium (side) heads and caps.

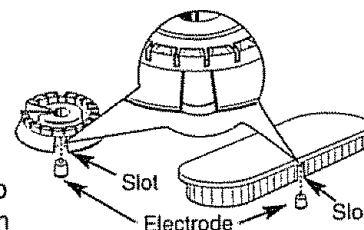

After cleaning, make sure the slot in the burner head is positioned over the electrode.

NOTE: Do not use steel wool or scouring powders to clean the burners.

CARE AND CLEANING (continued)

Burner Caps

Lift off when cool. Wash burner caps in hot, soapy water and rinse with clean water. You may scour with a plastic scouring pad to remove burned-on food particles.

Dry caps in a warm oven or with a cloth—don't reassemble them wet. Replace the caps back onto the burner heads.

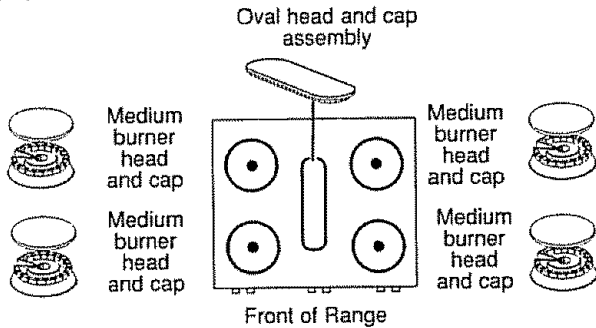

Burner Grates

Lift out when cool. First remove the center grate and then the side grates. Grates should be washed regularly and, of course, after spillovers. Wash them in hot, soapy water and rinse with clean water. After cleaning, dry them thoroughly by putting them in a warm oven for a few minutes. Don't put the grates back on the range while they are wet. When replacing the grates, be sure they're positioned securely over the burners.

To replace the grates:

1. Place the side grates in position on the cooktop.
2. Place the center grate on the cooktop making sure the locking feet hook over the side grates.

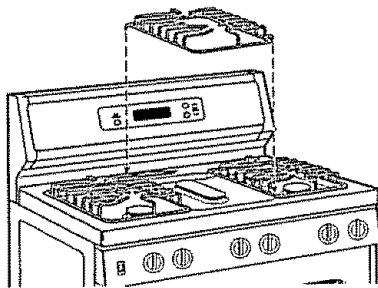

To get rid of burned-on food, place the grates in a covered container. Add 1/4 cup ammonia and let them soak several hours or overnight. Wash, rinse well and dry.

Although they are durable, the grates will gradually lose their shine, regardless of the best care you can give them. This is due to their continual exposure to high temperatures.

Do not operate a burner for an extended period of time without cookware on the grate. The finish on the grate may chip without cookware to absorb the heat.

Cooktop Surface

To avoid damaging the porcelain enamel surface of the cooktop and to prevent it from becoming dull, clean up spills right away. Foods with a lot of acid (tomatoes, sauerkraut, fruit juices, etc.) or foods with high sugar content could cause a dull spot if allowed to sit.

When the surface has cooled, wash and rinse. For other spills such as fat splatterings, etc., wash with soap and water once the surface has cooled. Then rinse and polish with a dry cloth.

Do not lift the cooktop. Lifting the cooktop can lead to damage and improper operation of the range.

Do not store flammable materials in an oven or near the cooktop. Do not store or use combustible materials, gasoline or other flammable vapors and liquids in the vicinity of this or any other appliance.

CARE AND CLEANING (continued)

Lower Control Panel (Front Manifold Panel) and Knobs

It's a good idea to wipe the control panel after each use of the oven. Use a damp cloth to clean or rinse.

For cleaning, use mild soap and water or a 50/50 solution of vinegar and water. For rinsing, use clean water. Polish dry with a soft cloth.

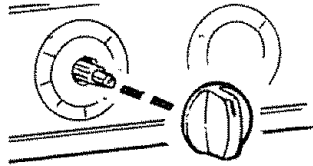

Do not use abrasive cleansers, strong liquid cleaners, plastic scouring pads or oven cleaners on the control panel—they will damage the finish. Do not bend control knobs by pulling them up or down or by hanging a towel or other such loads on them. This can damage the gas valve shaft.

The control knobs may be removed for easier cleaning. To remove knob, pull it straight off the stem. If knob is difficult to remove, place a towel or dishcloth between the knob and control panel and pull gently. Wash the knobs in soap and water, or in a vinegar and hot water solution.

Metal parts can be cleaned with soap and water. Do not use steel wool, abrasives, ammonia, acids or commercial oven cleaners. Dry with a soft cloth.

Oven Air Vents

Never block the vents (air openings) of the range. They provide the air inlet and outlet that are necessary for the range to operate properly with correct combustion. Air openings are located at the rear of the cooktop, at the top and bottom of the oven door, and at the bottom of the range, under the broiler compartment.

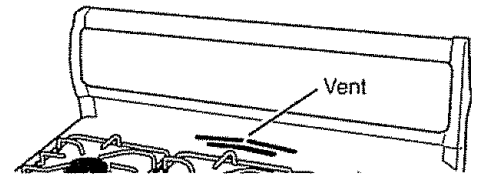

Vent appearance and location vary.

Oven Light Bulb

CAUTION: Disconnect electrical power to the oven at the main circuit breaker or fuse box before attempting to replace the oven light bulb. Do not touch a hot light bulb with wet hands or a wet cloth. Wait until the bulb has cooled and use a dry cloth.

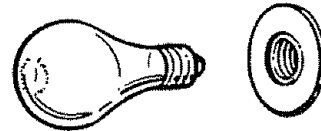

The light bulb is located in the upper left corner of the oven. Replace the bulb with a 40 watt appliance bulb only.

CARE AND CLEANING (continued)

Broiler Compartment

When the broiler compartment is cool, remove the grid and pan. Clean the broiler compartment with hot soapy water. Rinse thoroughly with a damp cloth and dry.

Broiler Pan and Grid

After broiling, remove the broiler pan from the broiler compartment. Remove the grid from the pan. Carefully pour out grease from the pan into a proper container. Wash and rinse the broiler pan and grid in hot water with a soap-filled or plastic scouring pad.

If food has burned on, sprinkle the grid with detergent while hot and cover with wet paper towels or a dishcloth, being careful not to touch the hot surfaces with your fingers. Soaking the pan and grid will also remove burned-on foods from them.

The broiler pan and grid may be cleaned with a commercial oven cleaner.

Both the broiler pan and grid can also be cleaned in a dishwasher.

Do not store a soiled broiler pan and grid anywhere in the range.

CAUTION: Do not clean the broiler pan or grid in a self-cleaning oven.

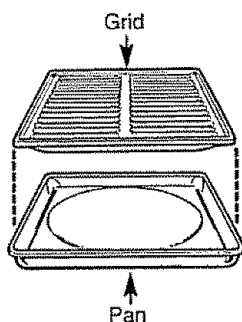

Oven Shelves

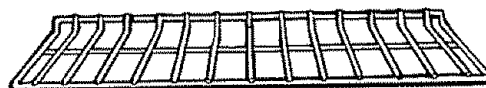

Clean the shelves with an abrasive cleanser or scouring pad. After cleaning, rinse the shelves with clean water and dry with a clean cloth.

Oven Bottom

The oven bottom has a porcelain enamel finish. To make cleaning easier, protect the oven bottom from excessive spillovers by placing a cookie sheet on the shelf below the shelf you are cooking on. You can use aluminum foil if you do not cover the whole shelf. This is particularly important when baking a fruit pie or other foods with a high acid content. Hot fruit fillings or other foods that are highly acidic (such as tomatoes, sauerkraut and sauces with vinegar or lemon juice) may cause pitting and damage to the porcelain enamel surface and should be wiped up immediately.

If a spillover does occur on the oven bottom, allow the oven to cool first. Remove the oven bottom for easier clean-up.

To remove the oven bottom:

1. Remove the knurled screws holding down the rear of the oven bottom.
2. Grasp the oven bottom at the finger slots on each side.
3. Lift the rear of the oven bottom enough to clear the lip of the range frame, push it back, and then pull it up and out.

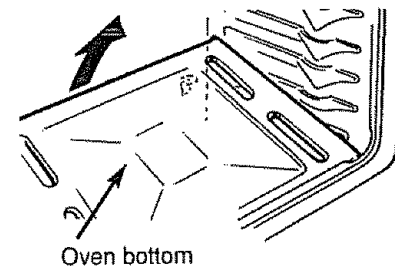

Make sure the oven bottom is in place before you turn the oven on for any reason.

Frequent wipings with mild soap and water (particularly after cooking meat) will prolong the time between major cleanings. Rinse thoroughly. Soap left on the oven bottom can cause stains.

For heavy soil, use an abrasive cleaner or a soap-filled scouring pad. A commercial oven cleaner may also be used, following the package directions.

CARE AND CLEANING

Porcelain Oven Interior

With proper care, the porcelain enamel interior will retain its attractive finish for many years.

Soap and water will normally do the job. Heavy spattering or spillovers may require cleaning with a mild abrasive cleanser. Soap-filled scouring pads may also be used. Do not allow food spills with a high sugar or acid content (such as tomatoes, sauerkraut, fruit juices or pie filling) to remain on the surface. They may cause dull spots even after cleaning.

Household ammonia may make the cleaning job easier. Place ½ cup (125 ml) ammonia in a shallow glass pan and leave in a cold oven overnight. The ammonia fumes will help loosen the burned-on grease and food.

When necessary, you may use a commercial oven cleaner. Follow the package directions.

Cautions about using spray-on oven cleaners:

- Be careful where the oven cleaner is sprayed.
- Do not spray oven cleaner on the electrical controls and switches because it could cause a short circuit and result in sparking or fire.
- Do not allow a film from the cleaner to remain on the temperature sensing bulb—it could cause the oven to heat improperly. (The bulb is located at the rear of the oven.) Carefully wipe the bulb clean after each oven cleaning, being careful not to move the bulb as a change in its position could affect how the oven bakes.
- Do not spray any oven cleaner on the outside of the oven door, handles or any exterior surface of the oven, cabinets or painted surfaces. Oven cleaner can damage these surfaces.

Lift-Off Oven Door

The oven door is removable but it is heavy. You may need help removing and replacing the door.

To remove the door, open it a few inches to the special stop position that will hold the door open. Grasp firmly on each side and lift the door straight up and off the hinges.

NOTE: Be careful not to place hands between the hinge and the oven door frame as the hinge could snap back and pinch fingers.

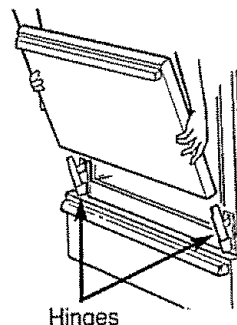

To replace the door, make sure the hinges are in the special stop position. Position the slots in the bottom of the door squarely over the hinges. Then lower the door slowly and evenly over both hinges at the same time. If hinges snap back against the oven frame, pull them back out.

To Clean the Door:

Do not allow excess water to run into any holes or slots in the door.

Inside of door:

- Allow to cool before cleaning. For light soil, wipe frequently with mild soap and water (especially after cooking meat). This will prolong the time between major cleanings. Rinse thoroughly.

NOTE: Soap left on the oven door causes additional stains when the oven is reheated.

- For heavy soil, you can use an oven cleaner and follow label instructions. Rinse well.

See "Cautions about using spray-on oven cleaners" below.

Outside of door:

- Use soap and water to thoroughly clean the top, sides and front of the oven door. Rinse well. You may also use a glass cleaner to clean the glass on the outside of the door.
- Spillage of marinades, fruit juices, tomato sauces and basting materials containing acids may cause discoloration and should be wiped up immediately. When surface is cool, clean and rinse.
- **Do not use oven cleaners, cleansing powders or harsh abrasives such as steel wool pads on the outside of the door.**

INSTALLATION INSTRUCTIONS

In the Commonwealth of Massachusetts:

- This product must be installed by a licensed plumber or gas fitter.
- When using ball-type gas shut-off valves, they shall be the T-handle type.
- A flexible gas connector, when used, must not exceed 3 feet.

FOR YOUR SAFETY

If you smell gas:

1. Open windows.
2. Don't touch electrical switches.
3. Extinguish any open flame.
4. Immediately call your gas supplier.

FOR YOUR SAFETY

Do not store or use combustible materials, gasoline or other flammable vapors and liquids in the vicinity of this or any other appliance.

BEFORE YOU BEGIN

Read these instructions completely and carefully.

IMPORTANT: Save these instructions for the local electrical inspector's use.

INSTALLER: Leave these instructions with the appliance after installation is completed.

CONSUMER: Keep this Use and Care Manual and the Installation Instructions for future use.

SERVICER: The electrical diagram is in an envelope attached to the back of the range.

This appliance must be properly grounded.

▲ WARNING

Improper installation, adjustment, alteration, service or maintenance can cause injury or property damage. Refer to this manual. For assistance or additional information, consult a qualified installer, service agency, manufacturer (dealer) or the gas supplier.

Never reuse old flexible connectors. The use of old flexible connectors can cause gas leaks and personal injury. Always use NEW flexible connectors when installing a gas appliance.

CAUTION:

Do not attempt to operate the oven of this range during a power failure.

IMPORTANT:

Remove all packing material and literature from oven before connecting gas and electrical supply to range.

INSTALLATION INSTRUCTIONS

DIMENSIONS

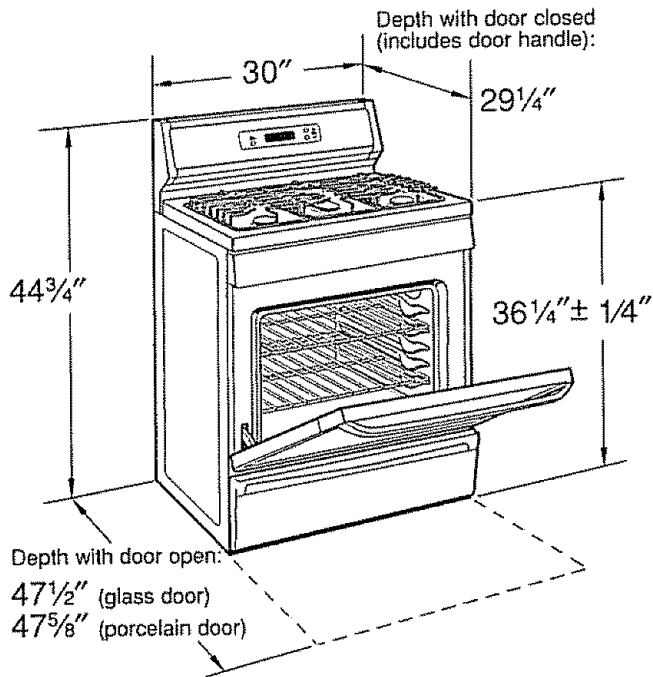

CLEARANCES

Provide adequate clearances between the range and adjacent combustible surfaces.

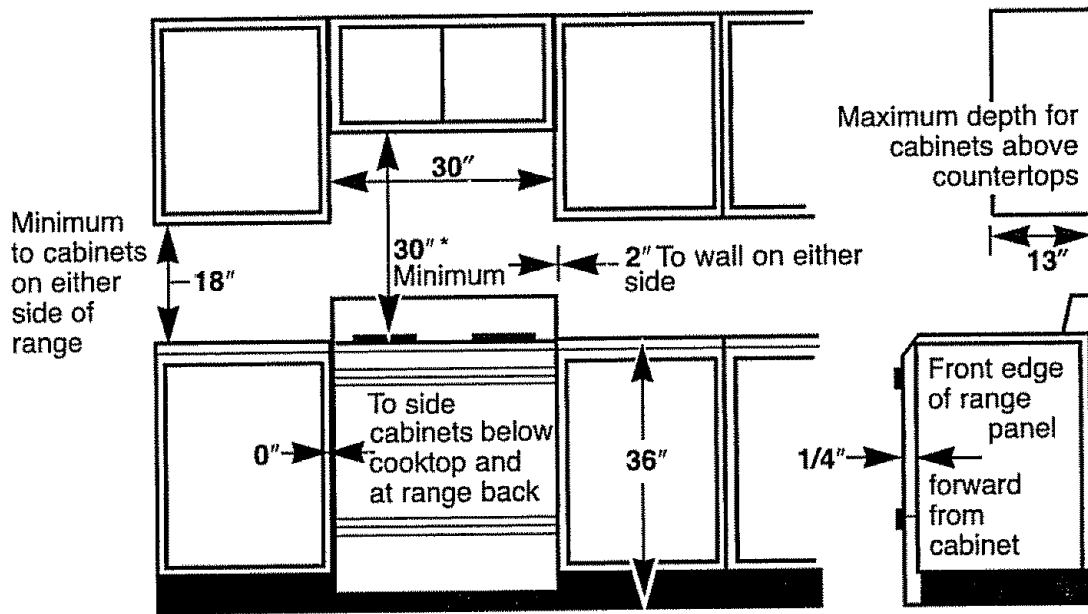

Front View

Side View

*Clearance between the cooking surface and protected cabinets MUST NEVER BE LESS THAN 24" (61 cm).

IMPORTANT SAFETY INSTRUCTIONS

- Installation of this range must conform with local codes, or in the absence of local codes, with the National Fuel Gas Code, ANSI Z223.1/NFPA.54, latest edition.

This range has been design-certified by CSA International according to ANSI Z21.1, latest edition and Canadian Gas Association according to CAN/CGA-1.1 latest edition. As with any appliance using gas and generating heat, there are certain safety precautions you should follow. You will find these precautions in the Important Safety Instructions section in the front of this manual. Read them carefully.

- Have your range installed by a qualified installer.
- Your range must be electrically grounded in accordance with local codes or, in the absence of local codes, in accordance with the National Electrical Code (ANSI/NFPA 70, latest edition). See Electrical Connections in this section.
- Before installing your range on linoleum or any other synthetic floor covering, make sure the floor covering can withstand 180°F (82°C) without shrinking, warping or discoloring. Do not install the range over carpeting unless a sheet of ¼" (6 mm) thick plywood or similar insulator is placed between the range and carpeting.
- Make sure the wall coverings around the range can withstand heat generated by the range up to 200°F (93°C).
- Avoid placing cabinets above the range. To reduce the hazard caused by reaching into the cabinets over the open flames of operating burners, install a ventilation hood over the range that projects forward at least 5" (12.7 cm) beyond the front of the cabinets.
- The ventilating hood must be constructed of sheet metal not less than 0.0122" (.31 mm) thick. Install above the cooking top with a clearance of not less than ¼" (6 mm) between the hood and the underside of the metal cabinet or combustible material. The hood must be at least as wide as the appliance and centered over the appliance. Clearance between the cooking surface and the ventilation hood surface **MUST NEVER BE LESS THAN 24" (61 cm)**.

EXCEPTION: Installation of a listed microwave oven or cooking appliance over the cooktop shall conform to the installation instructions packed with that appliance.

- If cabinets are placed above the range, allow a minimum clearance of 30" (76.2 cm) between the cooking surface and the bottom of unprotected cabinets.
- If a 30" (76.2 cm) clearance between cooking surface and overhead metal cabinets or combustible material cannot be maintained, protect the underside of the cabinets above the cooking top with not less than ¼" (6 mm) insulating millboard covered with sheet metal not less than 0.0122" (.31 mm) thick.
- Clearance between the cooking surface and protected cabinets **MUST NEVER BE LESS THAN 24" (61 cm)**.
- The vertical distance from the plane of the cooking surface to the bottom of adjacent overhead cabinets extending closer than 1" (2.5 cm) to the plane of the range sides must not be less than 18" (45.7 cm). (See the Dimensions and Clearances illustration in this section.)
- **CAUTION:** Items of interest to children should not be stored in cabinets above a range or on the backsplash of a range—children climbing on the range to reach items could be seriously injured.

▲ WARNING

- All ranges can tip and injury could result. To prevent accidental tipping of the range, attach an approved Anti-Tip device to the wall and floor. (See Installing the Anti-Tip Device in this section.)



To check if the device is installed and engaged properly, open the broiler compartment and inspect the rear leveling leg. Make sure it fits securely in the slot.



If you pull the range out from the wall for any reason, make sure the Anti-Tip device is engaged when you push the range back against the wall.

- For your safety, never use your range for warming or heating the room. Your oven and cooktop are not designed to heat your kitchen. Top burners should not be operated without cookware on the grate. Such abuse could result in fire and damage to your range and will void your warranty.
- Do not store or use combustible materials, gasoline or other flammable vapors and liquids in the vicinity of this or any other appliance. Explosions or fires could result.
- Do not use oven for a storage area. Items stored in the oven can ignite.
- Do not let cooking grease or other flammable materials accumulate in or near the range.

GENERAL

- See the Dimensions and Clearances illustration in this section for all rough-in and spacing dimensions. These dimensions must be met for safe use of your range. The location of the electrical outlet and pipe opening (see Gas Pipe and Electric Outlet Locations) may be adjusted to meet specific requirements.
- The range may be placed with 0" (0 cm) clearance (flush) at the back wall and at the side walls of the range.

LOCATION

Do not locate the range where it may be subject to strong drafts. Any openings in the floor or wall behind the range should be sealed. Make sure the openings around the base of the range that supply fresh air for combustion and ventilation are not obstructed by carpeting or woodwork.

PROTECT YOUR FLOOR

Your range, like many other household items, is heavy and can settle into soft floor coverings such as cushioned vinyl or carpeting. Use care when moving the range on this type of flooring. It is recommended that the following simple and inexpensive instructions be followed to protect your floor.

The range should be installed on a sheet of plywood (or similar material). When the floor covering ends at the front of the range, the area that the range will rest on should be built up with plywood to the same level or higher than the floor covering. This will allow the range to be moved for cleaning or servicing. See the IMPORTANT SAFETY INSTRUCTIONS on the previous page.

MODEL AND SERIAL NUMBER LOCATION

You'll find the model and serial numbers on a label on the front frame of the range, behind the broiler compartment.

TOOLS YOU WILL NEED

- Phillips and flat-blade screwdrivers
- Pencil and ruler
- Two pipe wrenches (one for backup)
- Open-end or adjustable wrench
- Drill, awl or nail
- Level

ADDITIONAL MATERIALS YOU MAY NEED

- Gas line shut-off valve
- Pipe joint sealant or UL-approved pipe thread tape with Teflon* that resists action of natural and LP gases
- Flexible metal appliance connector (1/2" inner diameter [I.D.]). A 5-foot (1.5 m) length is recommended for ease of installation but other lengths are acceptable. Never use an old connector when installing a new range.
- Flare union adapter for connection to gas supply line (3/4" or 1/2" NPT x 1/2" I.D.)
- Flare union adapter for connection to pressure regulator on range (1/2" NPT x 1/2" I.D.)
- Liquid leak detector or soapy water.
- Lag bolt or 1/2" outer diameter (O.D.) sleeve anchor (for Anti-Tip bracket mounted on concrete floors only).

*Teflon: Registered trademark of DuPont

INSTALLATION INSTRUCTIONS (continued)

PREPARATION

- Remove all tape and packaging.
- Take the accessory pack out of the oven.
- Check to be sure that no range parts have come loose during shipping.

STEP 1

Provide Adequate Gas Supply

Your range is designed to operate at a pressure of 4" (10.2 cm) of water column on natural gas or, if designed for LP gas (propane or butane), 10" (25.4 cm) of water column. Make sure you are supplying your range with the type of gas for which it is designed. This range is convertible for use on natural or propane gas. If you decide to use this range on LP gas, conversion must be made by a qualified LP installer before attempting to operate the range on that gas.

For proper operation, the pressure of natural gas supplied to the regulator must be between 4" (10.2 cm) and 13" (33 cm) of water column. For LP gas, the pressure supplied must be between 10" (25.4 cm) and 13" (33 cm) of water column.

When checking for proper operation of the regulator, the inlet pressure must be at least 1" (2.5 cm) greater than the operating (manifold) pressure as given above. The pressure regulator located at the inlet of the range manifold must remain in the supply line regardless of whether natural or LP gas is being used.

A flexible metal appliance connector used to connect the range to the gas supply line should have an I.D. of 1/2" and be 5 feet (1.5 m) in length for ease of installation. In Canada, flexible connectors must be single wall metal connectors no longer than 6 feet (1.8 m) in length.

STEP 2

Connect the Range to Gas

Shut off the main gas supply valve before disconnecting the old range and leave it off until new hook-up has been completed. Don't forget to relight the pilot on other gas appliances when you turn the gas back on.

Because hard piping restricts movement of the range, the use of a CSA International-certified flexible metal appliance connector is recommended unless local codes require a hard-piped connection. Never use an old connector when installing a new range. If the hard piping method is used, you must carefully align the pipe; the range cannot be moved after the connection is made.

To prevent gas leaks, use pipe joint compound or wrap Teflon* pipe thread tape around all male (external) pipe threads.

*Teflon: Registered trademark of DuPont

Gas Pipe and Electric Outlet Locations

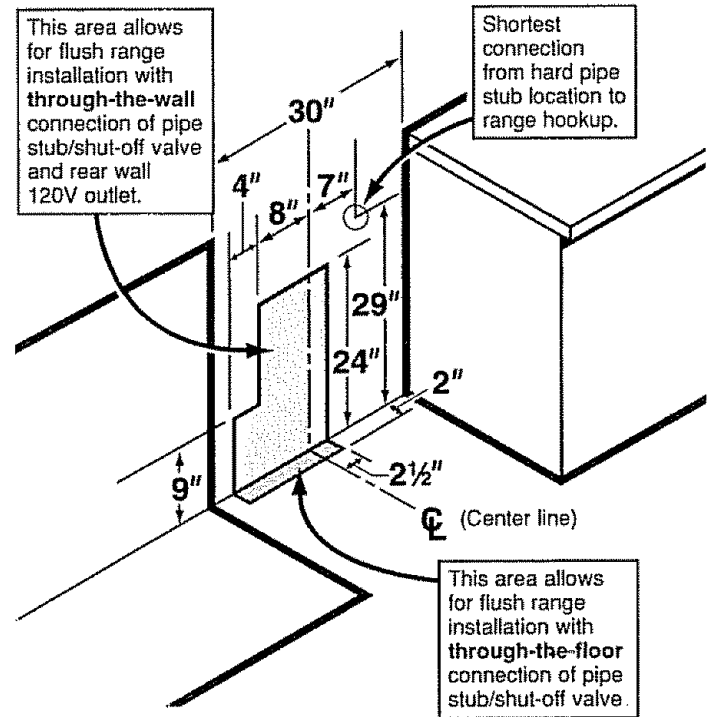

Flexible Connector and Rigid Pipe Hookups

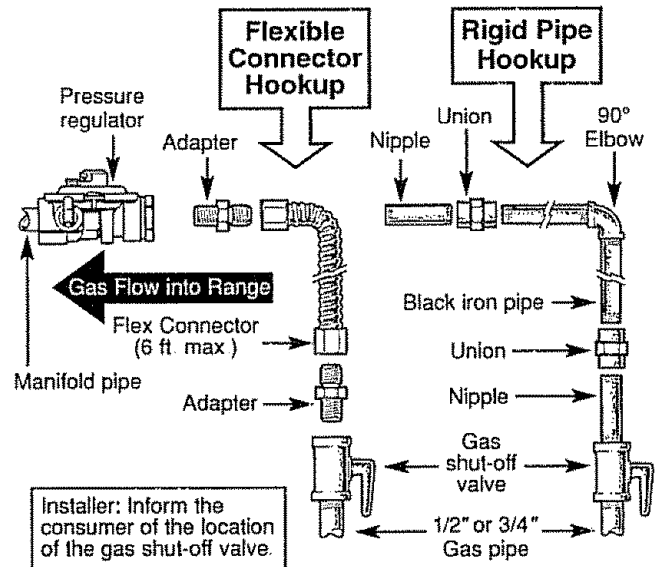

- If the Anti-Tip device supplied with the range does not fit this application, use the universal Anti-Tip device WB2X7909. Call 1-800-4-MY-HOME®.

INSTALLATION INSTRUCTIONS (continued)

1. Install a manual gas line shut-off valve in the gas line in an easily accessed location outside of the range. Make sure everyone operating the range knows where and how to shut off the gas supply to the range.
2. Install male 1/2" flare union adapter to the 1/2" NPT internal thread at inlet of pressure regulator. Use a back-up wrench on the regulator fitting to avoid damage.
3. Install male 1/2" or 3/4" flare union adapter to the NPT internal thread of the manual shut-off valve, taking care to back up the shut-off valve to keep it from turning.
4. Connect flexible metal appliance connector to the adapter on the range. Position range to permit connection at the shut-off valve.
5. When all connections have been made, make sure all range controls are in the OFF position and turn on the main gas supply valve. Use a liquid leak detector at all joints and connections to check for leaks in the system.

CAUTION: DO NOT USE A FLAME TO CHECK FOR GAS LEAKS.

When using test pressures greater than 1/2 psig to pressure test the gas supply system of the residence, disconnect the range and individual shut-off valve from the gas supply piping. When using test pressures of 1/2 psig or less to test the gas supply system, simply isolate the range from the gas supply system by closing the individual shut-off valve.

STEP 3 Electrical Connections

Electrical Requirements

120-volt, 60 Hertz, properly grounded branch circuit protected by a 15-amp or 20-amp circuit breaker or time delay fuse.

Extension Cord Cautions

Because of potential safety hazards associated with certain conditions, we strongly recommend against the use of an extension cord. However, if you still elect to use an extension cord, it is absolutely necessary that it be a UL-listed, 3-wire grounding-type appliance extension cord and that the current carrying rating of the cord in amperes be equivalent to, or greater than, the branch circuit rating.

Grounding—IMPORTANT (Please read carefully)

FOR PERSONAL SAFETY, THIS APPLIANCE MUST BE PROPERLY GROUNDED.

The power cord of this appliance is equipped with a three-prong (grounding) plug which mates with a standard three-prong grounding wall receptacle to minimize the possibility of electric shock hazard from this appliance.

PREFERRED METHOD

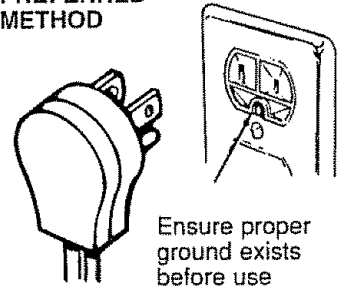

The customer should have the wall receptacle and circuit checked by a qualified electrician to make sure the receptacle is properly grounded.

Where a standard two-prong wall receptacle is encountered, it is the personal responsibility and obligation of the customer to have it replaced with a properly grounded three-prong wall receptacle.

DO NOT, UNDER ANY CIRCUMSTANCES, CUT OR REMOVE THE THIRD (GROUND) PRONG FROM THE POWER CORD.

Ground Fault Circuit Interrupters

Ground Fault Circuit Interrupters (GFCI's) are devices that sense leakage of current in a circuit and automatically switch off power when a threshold leakage level is detected. These devices must be manually reset by the consumer.

Although the National Electrical Code requires the use of GFCI's in kitchen receptacles installed to serve countertop appliances, GFCI's are not required or recommended in a receptacle serving a gas range.

Performance of the range will not be affected if operated on a GFCI-protected circuit, but occasional nuisance tripping of the GFCI breaker is possible. If the breaker trips, power to the range will switch off.

INSTALLATION INSTRUCTIONS (continued)

A: Usage Situations where Appliance Power Cord will be Disconnected Infrequently.

TEMPORARY METHOD

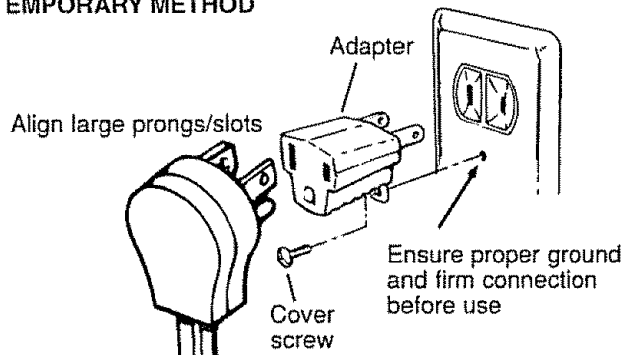

An adapter may be used only on a 15-amp circuit. Do not use an adapter on a 20-amp circuit. Where local codes permit, a **TEMPORARY CONNECTION** may be made to a properly grounded two-prong wall receptacle by the use of a UL-listed adapter, available at most hardware stores. The larger slot in the adapter must be aligned with the larger slot in the wall receptacle to provide proper polarity in the connection of the power cord.

CAUTION: Attaching the adapter ground terminal to the wall receptacle cover screw does not ground the appliance unless the cover screw is metal, and not insulated, and the wall receptacle is grounded through the house wiring. The customer should have the circuit checked by a qualified electrician to make sure the receptacle is properly grounded.

When disconnecting the power cord from the adapter, always hold the adapter with one hand. If this is not done, the adapter ground terminal is very likely to break with repeated use. Should this happen, **DO NOT USE** the appliance until a proper ground has again been established.

B: Usage Situations where Appliance Power Cord will Be Disconnected Frequently.

Do not use an adapter plug in these situations because disconnecting of the power cord places undue strain on the adapter and leads to eventual failure of the adapter ground terminal. The customer should have the two-prong wall receptacle replaced with a three-prong (grounding) receptacle by a qualified electrician before using the appliance.

The installation of appliances designed for mobile home installation must conform with the Manufactured Home Construction and Safety Standard, Title 24 CFR, Part 3280 (formerly the Federal Standard for Mobile Home Construction and Safety, Title 24, HUD, Part 280) or, when such standard is not applicable, the Standard for Manufactured Home Installations, latest edition (Manufactured Home Sites, Communities and Set-Ups), ANSI A225.1, latest edition, or with local codes.

Electric Disconnect Plug

This plug allows you to conveniently disconnect the range from electrical power.

1. Locate disconnect plug on the range back.
2. Pinch sides of connector and pull out of range back.

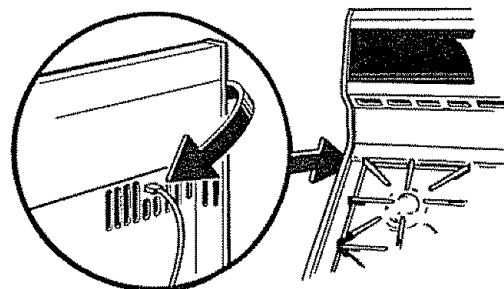

INSTALLATION INSTRUCTIONS (continued)

STEP 4

Seal the Openings

Seal any openings in the wall behind the range and in the floor under the range when hookups are completed.

STEP 5

Assemble the Surface Burners

1. Assemble the side burners as shown.

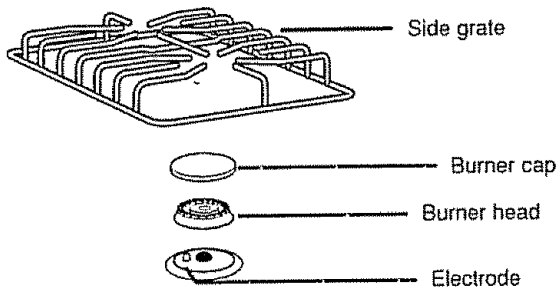

2. Assemble the center burner. Make sure that the locking feet on the center grate hook over the side grates.

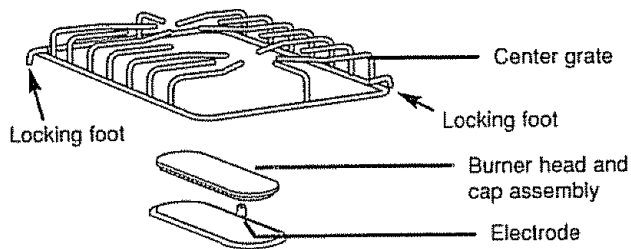

CAUTION: Do not operate the burner without all burner parts in place.

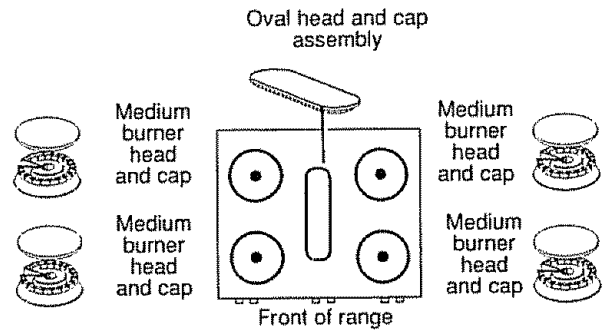

Place the burner heads and caps on the cooktop. Make sure that the heads and caps are placed in the correct locations. There is one oval (center) head and cap assembly and four medium (side) heads and caps.

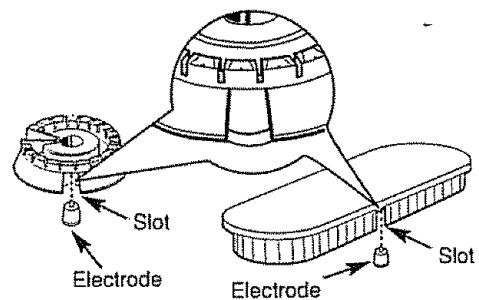

Make sure the slot in the burner head is positioned over the electrode

INSTALLATION INSTRUCTIONS (continued)

STEP 6

Check Ignition of Surface Burners

Operation of all cooktop and oven burners should be checked after all range and gas supply lines have been carefully checked for leaks.

Select a top burner knob and simultaneously push in and turn to LITE position. You will hear a snapping sound indicating proper operation of the spark module. Once the air has been purged from the supply lines, burners should light within 4 seconds. After burner lights, rotate knob out of the LITE position. Try each burner in succession until all burners have been checked.

NOTE: When one burner is turned to LITE, all the burners spark.

Quality of Flames

The combustion quality of burner flames needs to be determined visually.

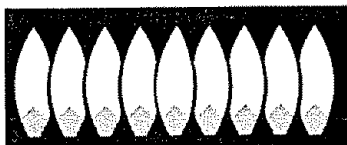

(A) Yellow flames—Call Sears for service

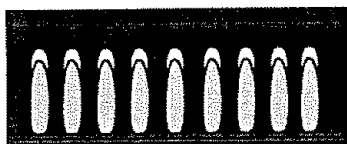

(B) Yellow tips on outer cones—Normal for LP gas

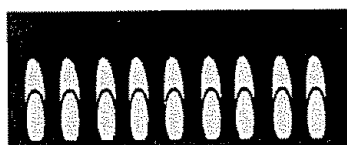

(C) Soft blue flames—Normal for natural gas

If burner flames look like (A), call Sears for service. Normal burner flames should look like (B) or (C), depending on the type of gas you use.

With LP gas, some yellow tipping on outer cones is normal.

STEP 7

Check Ignition of Oven Burner

Your oven is designed to operate quietly and automatically. To operate the oven, turn the OVEN TEMP knob to a setting above 200°F (93°C). After 30–90 seconds, the oven burner will ignite and burn until the set temperature is reached. The oven burner will continue to cycle on and off as necessary to maintain the oven at the temperature indicated by the OVEN TEMP knob.

Electronic ignition models require electrical power to operate. In case of a power outage, the oven burners on these models cannot be lit manually with a match. Gas will not flow unless the glow bar is hot.

If the oven is in use when a power outage occurs, the oven burner will shut off and cannot be re-lit until power is restored.

INSTALLATION INSTRUCTIONS (continued)

STEP 8

Adjusting the Oven Burner/Broiler Burner Air Adjustment Shutter, If Necessary

To determine if the oven/broiler burner flames are burning properly, first remove the oven bottom.

To remove the oven bottom:

1. Remove the knurled screws holding down the rear of the oven bottom.
2. Grasp the oven bottom at the finger slots on each side.
3. Lift the rear of the oven bottom enough to clear the lip of the range frame, push it back, and then pull it up and out.

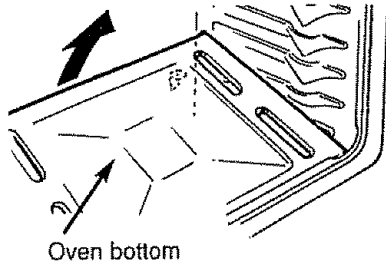

With the oven bottom removed, properly adjusted flames should have approximately 1" (2.5 cm) blue cones and, if range is supplied with natural gas, should burn with no yellow tipping. (With most LP gas, small yellow tips at the end of outer cones are normal.) Flames should not lift off the burner ports. If lifting is observed, gradually reduce air shutter opening until flames are stabilized.

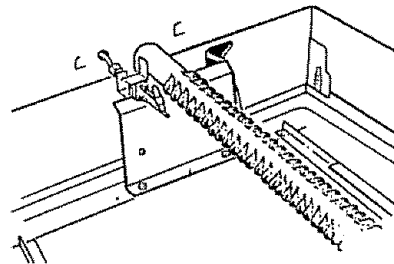

The shutter for the oven burner is near the back wall of the oven and behind the broiler compartment. Open the broiler compartment. See the Care and Cleaning section in this guide.

Remove the metal shield (on some models) at the rear of the cavity. The air adjustment shutter is behind this shield. To adjust the flow of air to the burner, loosen the Phillips-head screw and rotate the shutter to allow more or less air into the burner tube.

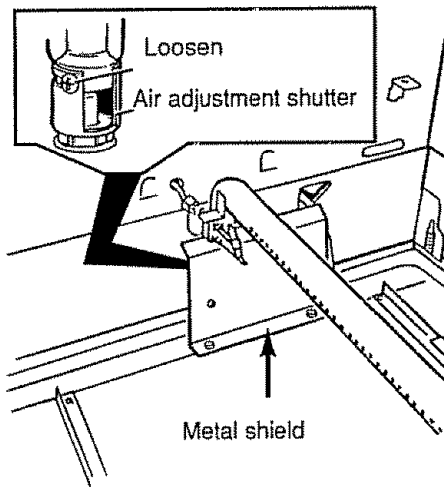

STEP 9

Leveling the Range

1. Install the oven shelves in the oven, then position the range where it will be installed. See the Oven Shelves section.
2. Check for levelness by placing a spirit level or a partially filled cup of water on one of the oven shelves. If using a spirit level, take two readings—with the level placed diagonally first in one direction and then the other.
3. Open the broiler compartment. The front leveling legs can be adjusted from the bottom and the rear legs can be adjusted from the top or the bottom.
4. Use an open-end or adjustable wrench to adjust the leveling legs until the range is level.
5. After the range is level, slide the range away from the wall so that the Anti-Tip device can be installed.

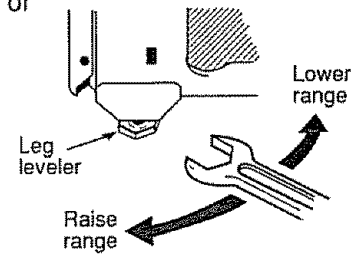
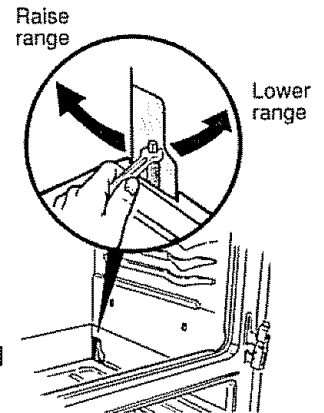

INSTALLATION INSTRUCTIONS (continued)

STEP 10

Installing the Anti-Tip Device

▲ WARNING:

- Range must be secured with an approved Anti-Tip device.
- Unless properly installed, the range could be tipped by you or a child standing, sitting or leaning on an open door.
- After installing the Anti-Tip device, verify that it is properly installed and engaged by opening the broiler compartment and inspecting the rear leveling leg. Make sure it fits securely in the slot.
- This range has been designed to meet all recognized industry tip standards for all normal conditions.
- The installation of the Anti-Tip device must meet all local codes for securing the appliance.
- The use of this device does not preclude tipping of the range when not properly installed.
- If the Anti-Tip device supplied with the range does not fit this application, use the universal Anti-Tip device WB2X7909. Call 1-800-4-MY-HOME®.

These Anti-Tip device installation instructions are for wood or concrete floors and walls. Any other type of construction may require special installation techniques to provide adequate fastening of the Anti-Tip device to the floor and wall.

1. Locate the device against the rear wall and either the right or left cabinet. If the countertop overhangs the cabinet, offset the device from the cabinet by the amount of overhang. If there is no adjacent cabinet, position the edge of the device at the desired location of the range side panel.
2. Use the device as a template and mark 2 hole positions on the wall and 2 hole positions on the floor. Use either the wood or concrete floor set of positions, depending on your floor type.

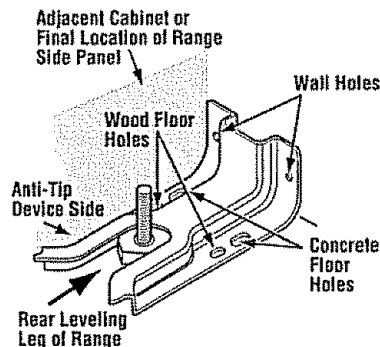

3. For wood construction, drill a 1/8" pilot hole in the center of each of the pre-marked wood floor and wall hole positions (a nail or awl may be used if a drill is not available). Fasten the Anti-Tip device with the 4 screws provided.

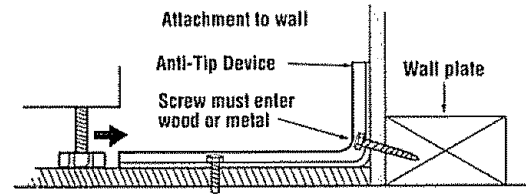

For concrete construction, you will need four 1/4" x 1 1/2" lag bolts and four 1/2" O.D. sleeve anchors (not provided). Drill the recommended size hole for the anchors into the concrete at the center of each pre-marked floor and wall hole position. Install the sleeve anchors into the drilled holes and then install the lag bolts through the device. **Do not overtighten the bolts.**

4. Slide the range against the wall, and check for proper installation by removing the broiler drawer, storage drawer, or kick panel and inspecting the rear leveling leg. Make sure it fits securely into the slot on the Anti-Tip device.

WHEN ALL HOOKUPS ARE COMPLETED:

MAKE SURE ALL OF THE CONTROLS ARE LEFT IN THE OFF POSITION.

MAKE SURE THE FLOW OF COMBUSTION AND VENTILATION AIR TO THE RANGE IS UNOBSTRUCTED.

Converting to LP gas

(or converting back to natural gas from LP)

This range leaves the factory set for use with natural gas. If you want to convert to LP gas, the conversion must be performed by a qualified LP gas installer.

The conversion instructions, sticker and LP orifices can be found attached to the range next to the pressure regulator.

Keep these instructions and the orifices in case you want to convert back to natural gas. Conversion back to natural gas must be performed by a qualified installer.

QUESTIONS? BEFORE YOU CALL FOR SERVICE . . .

PROBLEM	POSSIBLE CAUSE
TOP BURNERS DO NOT LIGHT OR DO NOT BURN EVENLY	<ul style="list-style-type: none"> • Make sure electrical plug is plugged into a live power outlet. • Burner holes on the side or around the top of burner may be clogged. Remove burner heads and burner caps. Clean them with a sewing needle or bare wire. Make sure you do not enlarge the burner holes. Check electrode area for burned-on food or grease.
BURNER FLAMES VERY LARGE OR YELLOW	<ul style="list-style-type: none"> • If range is connected to LP gas, contact the person who installed your range or made the conversion.
CLOCK DOES NOT WORK	<ul style="list-style-type: none"> • Plug on the range is not completely inserted in the electrical outlet. • Range electrical plug must be securely plugged into a live power outlet. Check for blown fuse or tripped circuit breaker.
OVEN LIGHT DOES NOT COME ON	<ul style="list-style-type: none"> • Bulb may be loose or burned out. See the Oven Light Bulb section. • Electrical plug must be plugged into a live power outlet.
OVEN WILL NOT WORK	<ul style="list-style-type: none"> • Plug on the range is not completely inserted in the electrical outlet. • The circuit breaker in your house has been tripped, or a fuse has been blown. • Oven controls not properly set.
OVEN TEMPERATURE TOO HOT OR TOO COLD	<ul style="list-style-type: none"> • The OVEN TEMP knob needs adjustment. See the Adjust the Oven Thermostat—Do It Yourself section.
FOOD DOES NOT ROAST OR BAKE PROPERLY	<ul style="list-style-type: none"> • Oven controls not properly set. See the Baking or Roasting section. • Shelf position is not correct. • Incorrect cookware or cookware of improper size is being used. • Oven thermostat needs adjustment. See the Adjust the Oven Thermostat—Do It Yourself section. • Aluminum foil used improperly in the oven. See the Using the Oven section. • Oven bottom not securely seated in position. See the Care and Cleaning section.
FOOD DOES NOT BROIL PROPERLY	<ul style="list-style-type: none"> • Oven controls not properly set. See the Broiling section. • Oven door and/or broiler compartment not closed. • Food is being cooked on a hot pan. • Cookware is not suited for broiling. • Aluminum foil used on the broiler pan grid has not been fitted properly and slit as recommended. • Oven bottom not securely seated in position. See the Care and Cleaning section.
STRONG ODOR	<ul style="list-style-type: none"> • Improper air/gas ratio in oven. Adjust oven burner air shutter. See the Installation Instructions section. • An odor from the insulation around the oven liner is normal for the first few times oven is used. This is temporary.



FREE-STANDING GAS RANGE WARRANTY

FULL ONE YEAR WARRANTY ON ALL PARTS

If, within one year from the date of installation, any part fails to function properly due to a defect in material or workmanship, Sears will repair or replace it, at our option, free of charge

If this product is subjected to other than private family use, the above warranty is effective for only 90 days

WARRANTY SERVICE IS AVAILABLE BY CALLING SEARS SERVICE AT 1-800-4-MY-HOME®

This warranty gives you specific legal rights, and you may also have other rights which vary from state to state.

Sears Roebuck and Co Dept 817 WA Hoffman Estates, IL 60179

Master Protection Agreements

Congratulations on making a smart purchase. Your new Kenmore® product is designed and manufactured for years of dependable operation. But like all products, it may require preventive maintenance or repair from time to time. That's when having a Master Protection Agreement can save you money and aggravation.

Purchase a Master Protection Agreement now and protect yourself from unexpected hassle and expense.

The Master Protection Agreement also helps extend the life of your new product. Here's what's included in the Agreement:

- ✓ **Expert service** by our 12,000 professional repair specialists
- ✓ **Unlimited service and no charge** for parts and labor on all covered repairs
- ✓ **"No-lemon" guarantee**—replacement of your covered product if four or more product failures occur within twelve months
- ✓ **Product replacement** if your covered product can't be fixed
- ✓ **Annual Preventive Maintenance Check** at your request – no extra charge
- ✓ **Fast help by phone**—phone support from a Sears technician on products requiring in-home repair, plus convenient repair scheduling
- ✓ **Power surge protection** against electrical damage due to power fluctuations
- ✓ **Rental reimbursement** if repair of your covered product takes longer than promised

Once you purchase the Agreement, a simple phone call is all that it takes for you to schedule service. You can call anytime day or night, or schedule a service appointment online.

Sears has over 12,000 professional repair specialists, who have access to over 4.5 million quality parts and accessories. That's the kind of professionalism you can count on to help prolong the life of your new purchase for years to come. Purchase your Master Protection Agreement today!

Some limitations and exclusions apply.

For prices and additional information, call 1-800-827-6655.

Sears Installation Service

For Sears professional installation of home appliances, garage door openers, water heaters, and other major home items, in the U.S.A. call 1-800-4-MY-HOME®.