

TERM.	CIRCUIT	REGULAR				QUICK WASH			EASY CARE			DELICATE & HAND WASH CYCLE		
		HEAVY	WASH	MED	LIGHT	WASH	RINSES & SPINS	FINAL SPIN	WASH	RINSES & SPINS	FINAL SPIN	WASH	RINSES & SPINS	FINAL SPIN
0/0	1 T													
0	2 1 T													
1	23 22 T													
2	5 6 B													
3	23 19 T													
4	5 7 T													
5	23 16 T													
6	11 10 T													
7	23 13 T													
8	14 17 T													
9	23 12 T													
10	17 16 T													
11	23 7 T													
12	20 9 T													
19	24 22 T													

STEP TIME (MIN.)	STEP NO.	1	2	3	4	5	6	7	8	9	10	11	12	13	14	15	16	17	18	19	20	21	22	23	24	25	26	27	28	29	30	31	32	33	34	35	36	37	38	39	40	41	42	43	44	45	46	47	48	49	50
3.0	1	2.0	6.7	6.0	1.0	2.0	3.0	2.5	3.0	1.0	2.0	3.0	2.0	8.12	2.6	6.0	1.0	2.0	2.0	3.0	2.0	8.12	2.6	6.7	6.0	1.0	3.0	1.0	3.0	3.0	3.0	3.0	7.2	3.0	3.0	7.2	2.6	10.0	1.0	3.0	3.0	3.0	2.0	1.0	2.0	5.1	2.6				

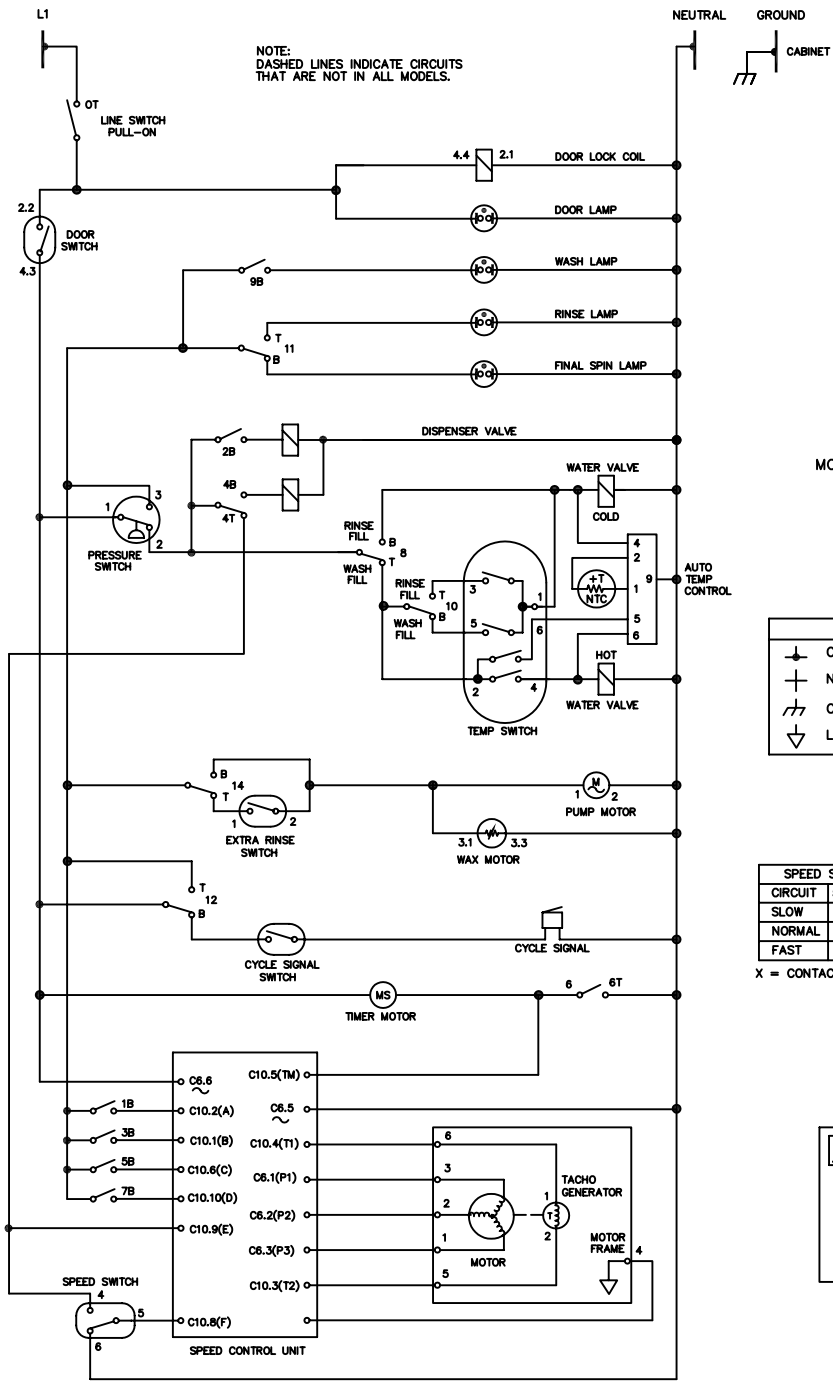

COMPONENT RESISTANCE TABLE		
ELECTRICAL COMPONENT	RESISTANCE Ω @ 77°F (25°C)	
WATER VALVE SOLENOIDS	880 ±10%	
DOOR LOCK SOLENOID	380 ±10%	
TIMER MOTOR	2425 ±6%	
PUMP MOTOR	15 ±7%	
DISPENSER VALVE SOLENOIDS	1100 ±7%	
MOTOR	M1 TO M2	2.6 ±7%
	M2 TO M3	2.6 ±7%
	M1 TO M3	2.6 ±7%
	M5 TO M6	184 ±7%

TEMPERATURE SWITCH				
WASH/RINSE	CIRCUIT			
	1-3	1-5	2-6	2-4
H/C				X
W/C		X		X
C/C		X		X
W/W	X	X		X
REG C/C		X	X	X
REG W/C		X	X	X
REG W/W	X	X	X	X

H=HOT W=WARM C=COLD
REG=REGULATED X=CLOSED



MOTOR PLUG-MALE (END VIEW)

WIRING CODES	
⊕	CONNECTION
+	NO CONNECTION
⏏	CABINET GROUND
⏏	LOCAL GROUND

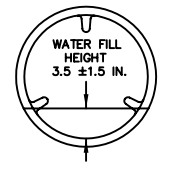

NO LOAD, START POSITION OF PERMANENT PRESS

SPEED SWITCH	
CIRCUIT	5-6 4-5
SLOW	X
NORMAL	X
FAST	

X = CONTACTS CLOSED

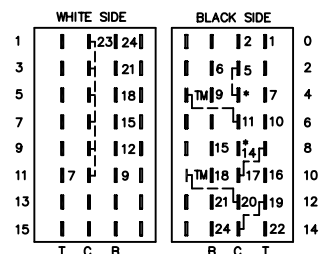

TIMER PLUG-MALE (END VIEW)

WARNING TO REDUCE THE RISK OF ELECTRICAL SHOCK DISCONNECT THIS APPLIANCE FROM THE POWER SUPPLY BEFORE ATTEMPTING ANY USER MAINTENANCE. TURNING THE CONTROLS TO THE OFF POSITION DOES NOT DISCONNECT THIS APPLIANCE FROM THE POWER SUPPLY.



TABLEAU DE RÉSISTANCE DES COMPOSANTS		
COMPOSANT ÉLECTRIQUE	RÉSISTANCE Ω @ 77°F (25°C)	
SOLÉNOÏDE DU ROBINET D'EAU	880 ±10%	
SOLÉNOÏDE DU LOQUET DE PORTE	380 ±10%	
MOTEUR DE MINUTERIE	2425 ±6%	
MOTEUR DE POMPE	15 ±7%	
SOLÉNOÏDE DU ROBINET DISTRIBUTEUR	1100 ±7%	
MOTEUR	M1 VERS M2	2.6 ±7%
	M2 VERS M3	2.6 ±7%
	M1 VERS M3	2.6 ±7%
	M5 VERS M6	184 ±7%

PRISE MÂLE MOTEUR (VUE EXTR)

CODES DE CÂBLAGE	
⊕	CONNEXION
+	AUCUNE CONNEXION
⏏	MISE A LA TERRE DE CARROSSERIE
⏏	MISE A LA TERRE DE LOCAL

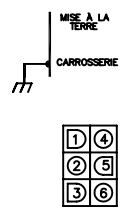
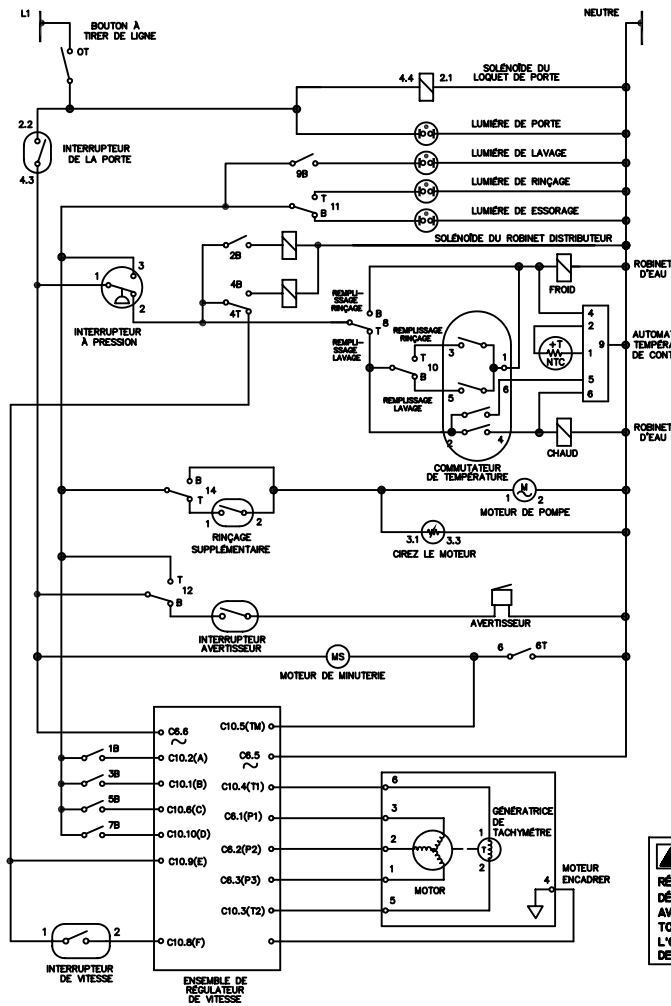
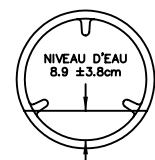

SANS CHARGE, POSITION DE DÉMARRAGE DU CYCLE POUR TISSU À PRESSAGE PERMANENT

COMMUTATEUR DE TEMPÉRATURE	
CIRCUIT	
LAVAGE/RINÇAGE	1-3 1-5 2-6 2-4
C/F	
T/F	X
F/F	X
T/T	X
AUTO F/F	X
AUTO T/F	X
AUTO T/T	X

C=CHAUD T=TIÈDE F=FROID
AUTO=AUTOMATIQUE X=FERMÉS

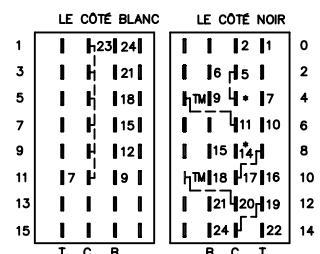

PRISE MÂLE MINUT (VUE EXTR)

AVERTISSEMENT POUR RÉDUIRE LE RISQUE DE CHOC ÉLECTRIQUE, DÉBRANCHER CET APPAREIL DE L'ALIMENTATION AVANT DE PROCÉDER À L'ENTRETIEN. EN TOURNANT LES COMMANDES À LA POSITION ARRÊT, L'ON NE COUPE PAS L'ALIMENTATION ÉLECTRIQUE DE L'APPAREIL.

SCHÉMA DE CÂBLAGE NO. DE PIÈCE 134573700



TABLA DE RESISTENCIA DE LOS COMPONENTES		
COMPONENTE ELÉCTRICO	RESISTENCIA Ω @ 77°F (25°C)	
SOLENOÏDE DE LA VÁLVULA DEL AGUA	880 ±10%	
SOLENOÏDE DE CIERRE DE LA PUERTA	380 ±10%	
MOTOR DE CONTADOR DE TIEMPO	2425 ±6%	
BOMBA DE MOTOR	15 ±7%	
SOLENOÏDE DE LA VÁLVULA DEL DISTRIBUIDOR	1100 ±7%	
MOTOR	M1 A M2	2.6 ±7%
	M2 A M3	2.6 ±7%
	M1 A M3	2.6 ±7%
	M5 A M6	184 ±7%

FICHA DE CONTADOR DE MACHO MOTOR (VISTA DE EXTREMO)

CODIGOS DEL CABLEADO	
⊕	CONNEXION
+	SIN CONNEXION
⏏	PUSTA A TIERRA DE CAJA
⏏	PUSTA A TIERRA DE LOCAL

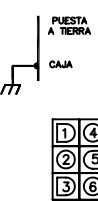
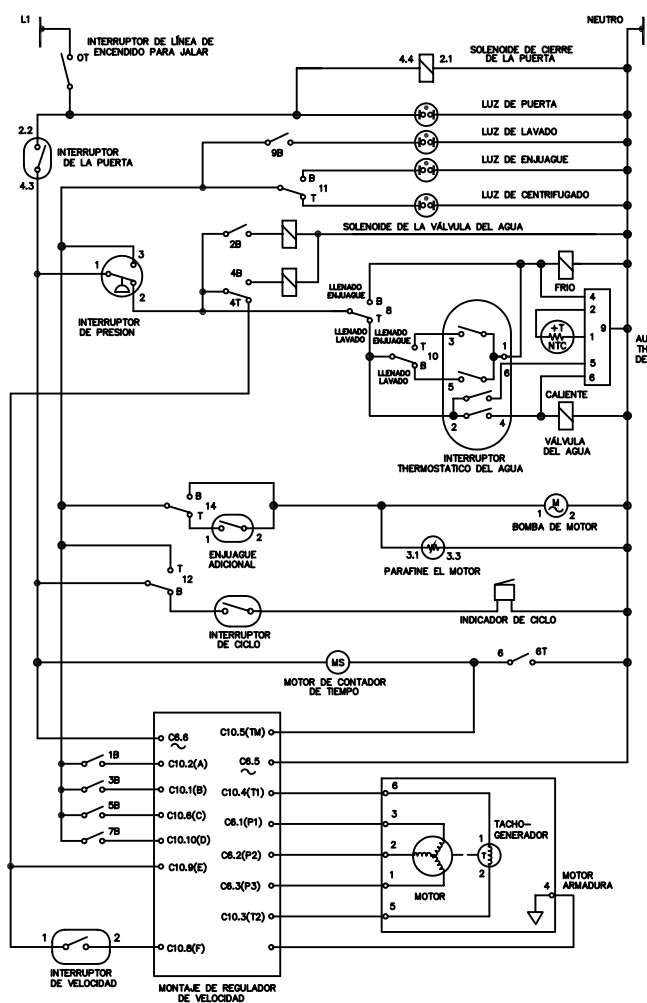

SIN CARGA, POSICIÓN DE ARRANQUE DEL CICLO PARA TALAS DE PLANCHADO PERMANENTE.

INTERRUPTOR TERMOSTÁTICO DEL AGUA	
CIRCUITO	
LAVADO/ENJUAGUE	1-3 1-5 2-6 2-4
C/F	
T/F	X
F/F	X
T/T	X
AUTO F/F	X
AUTO T/F	X
AUTO T/T	X

C=CALIENTE T=TEMPLADO F=FRIO
AUTO=AUTOMÁTICO X=CERRADOS



FICHA DE CONTADOR DE MACHO TIEMPO (VISTA DE EXTREMO)

ADVERTENCIA PARA REDUCIR EL RIESGO DE CHOQUE ELÉCTRICO, DESENCIPLA ESTE APARATO DE LA ALIMENTACIÓN ELÉCTRICA ANTES DE EFECTUAR EL MANTENIMIENTO. AL GIRAR LOS CONTROLES A LA POSICIÓN OFF (APAGADO) NO SE CORTA LA ALIMENTACIÓN ELÉCTRICA AL ARTEFACTO.

DIAGRAMA DE CONEXIONES NO. DE PIEZA 134573700

TECH SHEET - RETAIN FOR SERVICE TECHNICIAN



WARNING Disconnect from Electrical Supply Before Servicing Washer.

WIRING DIAGRAM

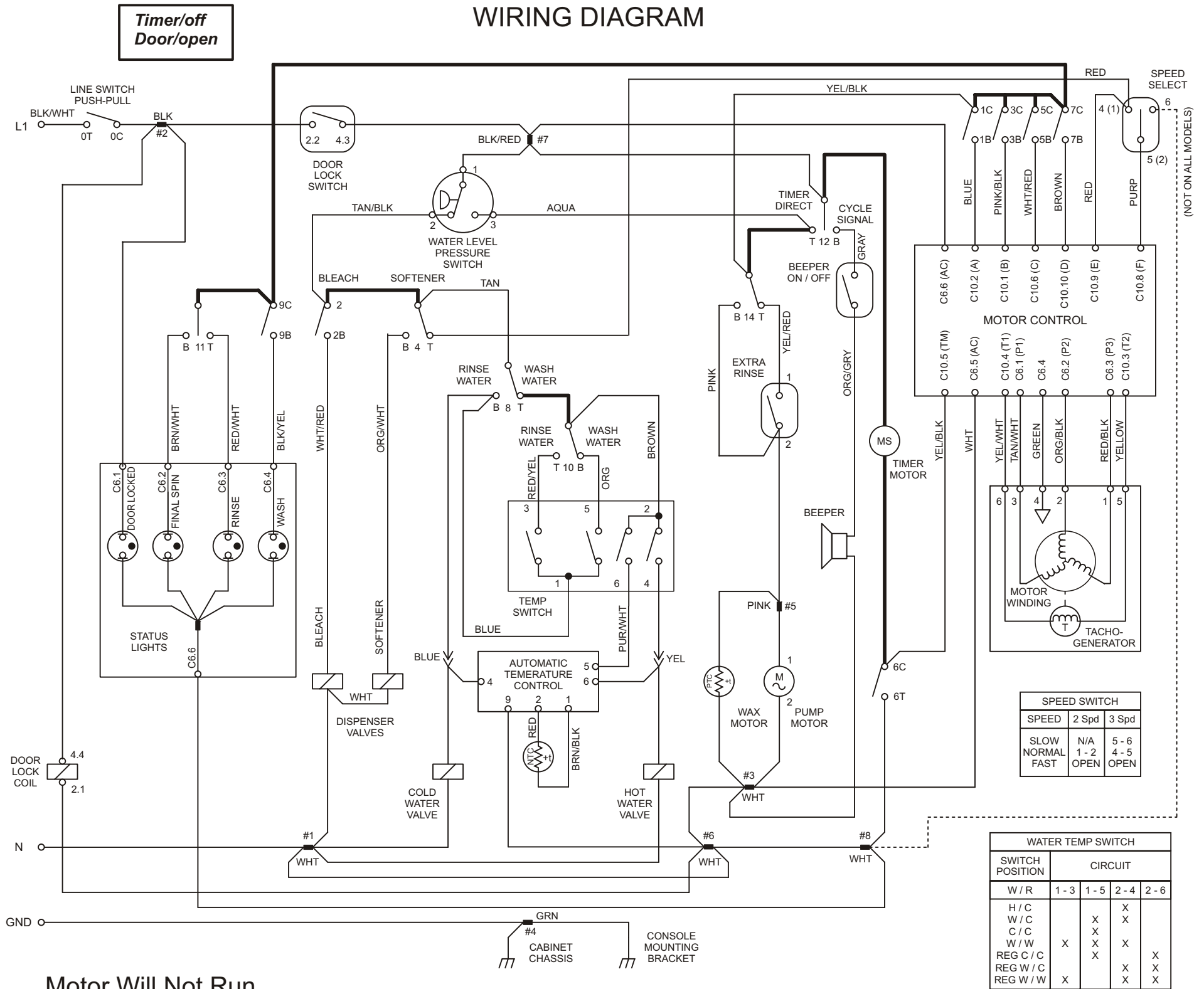

Motor Will Not Run

- CHECK FOR POWER:**
Advance the timer knob to the drain increment. If the drain pump does not run, check household safety circuit. If the drain pump runs go to step 2.
- CHECK FOR MOTOR MOVEMENT:**
Turn the water off to the washer. Remove electrical power from the washer and remove the back panel. Remove the motor drive belt. Reconnect electrical power and set the timer to the start of the Regular wash cycle and pull the knob out. If motor does not rotate, check for a poor connection in the timer line switch or door lock switch. If good, and motor does not run go to step 3.
- MEASURE VOLTAGES:**
Remove the six pin plug from the speed control unit. Measure the voltage between pins 5 and 6 on the harness. If the meter reads 0 check the connection in the timer line switch or door lock. If the meter reads 120 Vac go to step 4.
- Set the timer to the Heavy Wash position of the Regular wash cycle. Remove the ten pin plug from the speed control unit. Measure the voltage between pins 1, 2, 6 and 10 of the ten pin plug to pin 5 of the 6 pin plug on the harness. The voltage at pins 2, 6, and 10 should read 120 Vac and 0 Vac at pin 1. If not, check timer contacts 1C to 1B, 5C to 5B, and 7C to 7B for closed contacts, and 3C to 3B for open contacts. If the voltage readings are correct, go to step 5.
- MEASURE RESISTANCES:**
Check the fuse on the speed control board. If the fuse is open, replace the speed control board. If good, go to step 6.
- Remove the 6 pin plug from the speed control unit. Measure the resistance between pins 1 and 2, 2 and 3, and 3 and 1 of the speed control unit. If the meter reads other than 3 Meg ohms \pm 10%, replace the speed control board.
- Remove electrical power from the washer. With an ohmmeter check the resistance between pins 1 and 2, 2 and 3, and 3 and 1 of the six pin plug on the harness. If the meter reads other than 2.6 ohms \pm 7%, replace the motor.

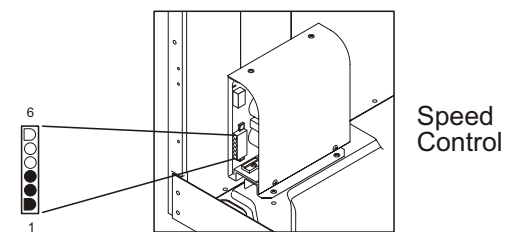

Quick Facts

- The timer motor will not run continuously. The speed control unit controls the timer motor and advances the timer when needed.
- In some tumble modes, the tub may not tumble for the first 16 to 20 seconds after start-up.
- Extremely low water pressure may cause tub rotation to stop until WLC satisfied.

IMPORTANT SAFETY NOTICE

This information is intended for use by technicians possessing adequate background of electrical, electronic and mechanical experience. Any attempt to repair a major appliance may result in personal injury and property damage. The manufacturer or seller cannot be responsible for the interpretation of this information, nor can it assume any liability in connection with its use.

IMPORTANT

If grounding wires, screws or clips used to complete a path to ground are removed for service, they must be returned to their original position and properly fastened. Certain internal parts are intentionally NOT grounded and may present a risk of electric shock only during servicing. Do not contact the following parts while the appliance is energized: pump, drive motor and electronic control boards.

WARNING

This information is intended for use by persons having electrical and mechanical training and a level of knowledge of these subjects generally considered acceptable in the appliance repair trade. The manufacturer or seller can not be responsible, nor assume any liability, for injury or damage of any kind arising from the use of this data.

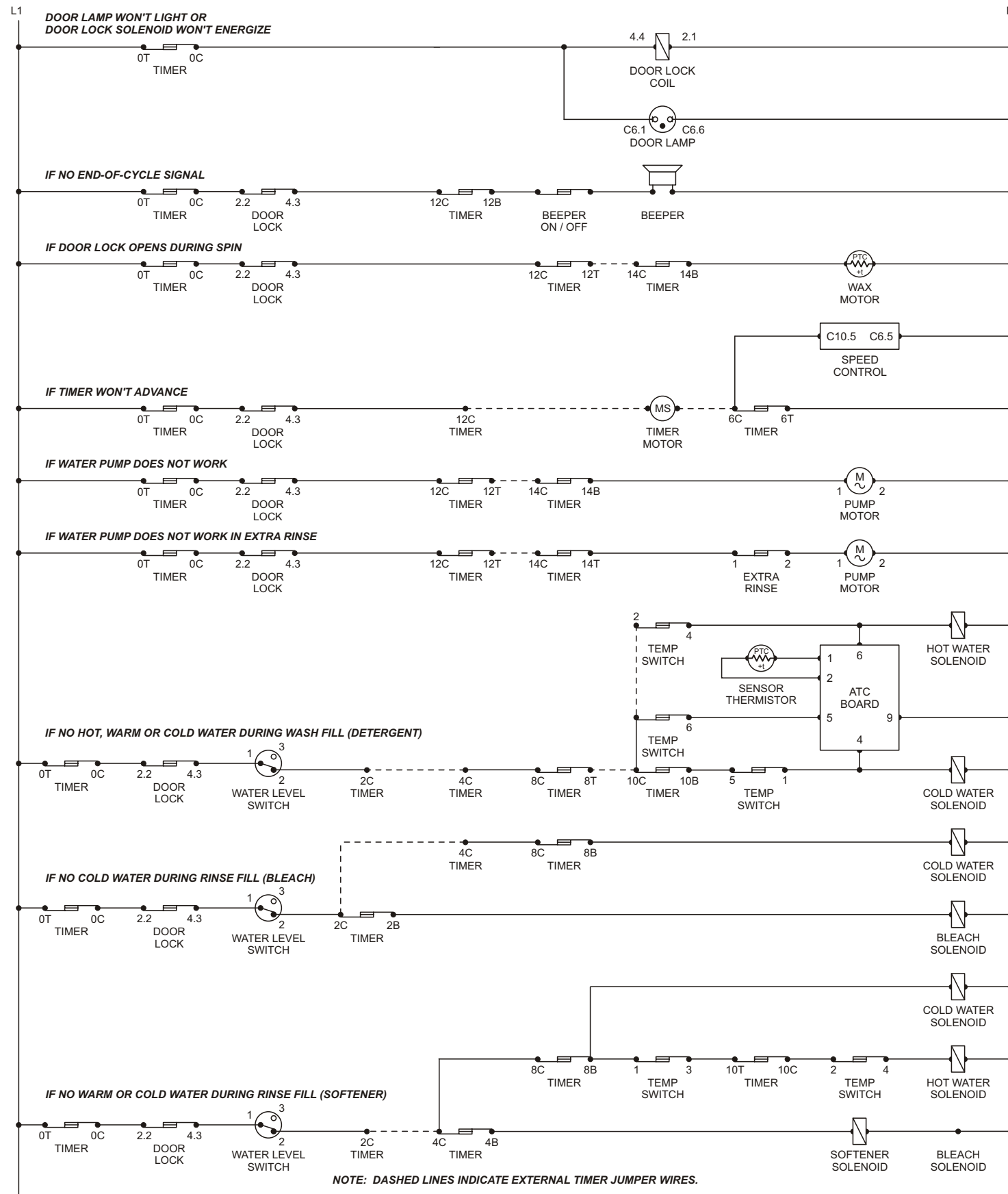

IMPORTANT
 If grounding wires, screws or clips used to complete a path to ground are removed for service, they must be returned to their original position and properly fastened. Certain internal parts are intentionally NOT grounded and may present a risk of electric shock only during servicing. Do not contact the following parts while the appliance is energized: pump, drive motor and electronic control boards.

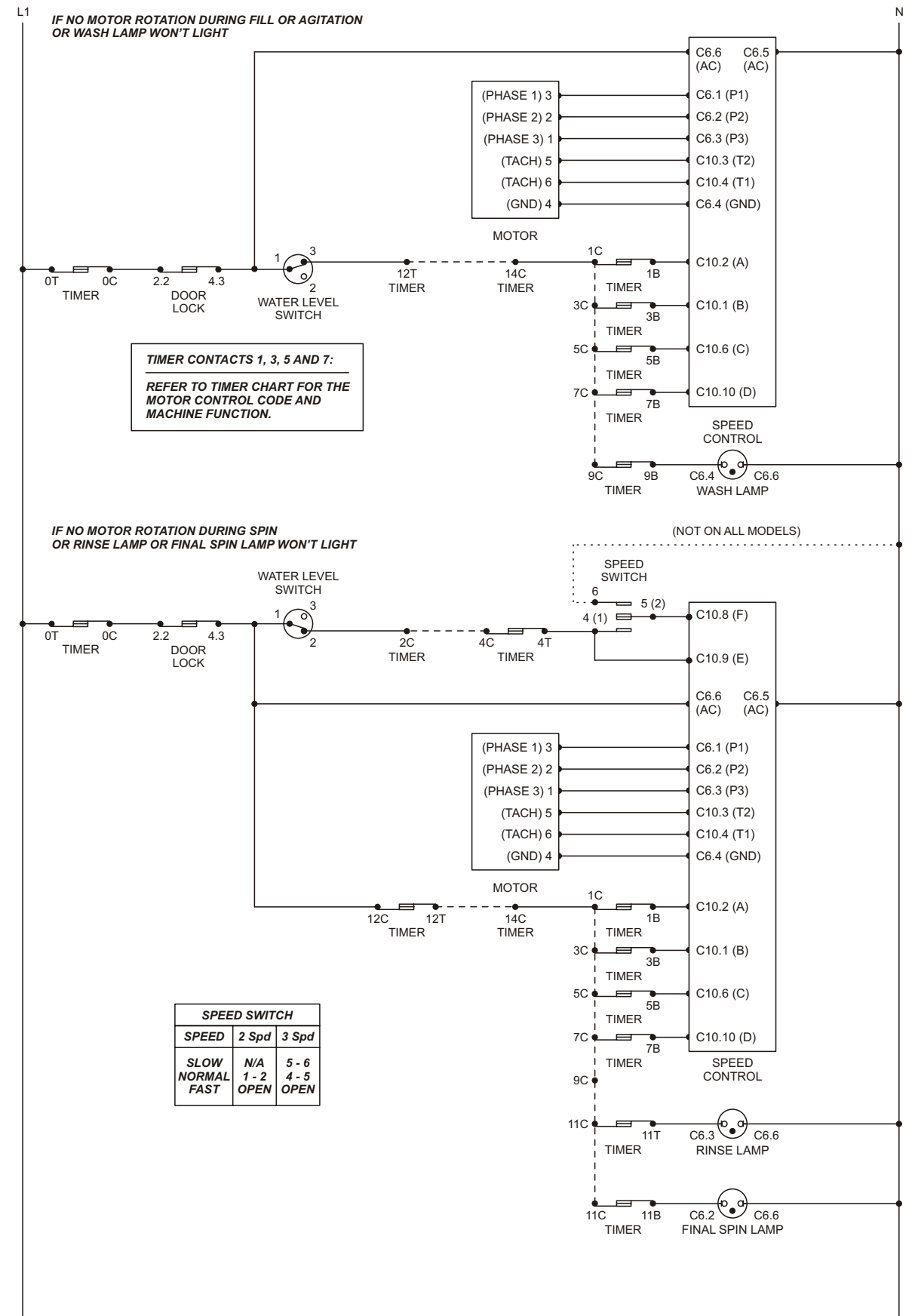

DIAGNOSTIC STRIP CIRCUITS