

ELECTRIC BUILT-IN DOUBLE OVEN

USE AND CARE MANUAL

**Copy Your Model and Serial Numbers
IN THE BOX BELOW**

Model and Serial numbers are on a plate, behind the oven door, on the front frame. If you call for service, or with a question, have this information ready.

Keep this book, your installation guide, your warranty and the sales slip together.

Model No.: _____

Serial No.: _____

Purchase Date: _____

43418358

SAFETY RULES 3,4

HOW TO USE YOUR OVEN 5-7

- Clock and Oven Controls 5,6
- Oven Light 7
- Oven Vent 7
- New Oven Odor 7
- Preheating 7

COOKING HINTS 8-10

- Rack and Pan Arrangement 8
- Using Foil 8
- Broiling Tips 9
- Positioning Broiler Pan 9
- Choosing Oven Cookware 10
- Common Baking Problems and Causes 10

CLEANING AND CARE 11-15

- Oven Cleaning 11,12
- Cleaning Chart 13
- Removable Oven Doors 14
- Removable Oven Racks 15
- Replacing the Oven Light 16
- Removable Oven Control Knob 16
- Adjusting Oven Temperature 17

PREVENTING SERVICE CALLS 18

IMPORTANT INSTRUCTIONS

Read the Safety Rules below and all operating instructions before using this appliance.

Keep this manual for later use.

Be sure your oven is installed and grounded properly.

Never try to fix or replace any part of the oven unless this book tells you to. All other work should be done by a skilled technician.

Never block free airflow through the oven vent. See page 7.

Teach your children not to play with oven knobs or any other part of the range. Never let children sit or stand on the open oven door.

Never leave children alone or unwatched where an oven is in use. Children should never be allowed to sit or stand on the open oven door.

Teach children not to play with oven controls.

Never use your oven for warming or heating a room. Such use can be dangerous and hurt oven parts.

Never heat unopened food containers. Pressure build-up may make container burst and cause injury.

Never wear loose clothing while using your oven. Such clothes could catch fire.

Always use care when opening oven door. Let hot air or steam out before moving food.

Always move oven racks while oven is cool.

Always use dry pot holders when removing pans from the oven. Moist or damp pot holders can cause steam burns. Do not use a towel or other bulky cloth. It may catch fire on the element.

Never try to move a pan of hot fat, especially a deep fat fryer. Wait until the fat has cooled.

Always keep the oven area clear and free from things that will burn, gasoline and other flammable vapors and liquids. Never store things in an oven. These things may catch fire and plastic items may melt and burn.

Never touch oven heating elements or interior surfaces of oven. Heating elements and nearby areas may be hot enough to burn you even though they are dark in color. During and after use, do not let clothing or flammable materials touch heating elements or oven surfaces until they have had time to cool. Other surfaces that may become hot during use are the oven vent duct and the oven door.

When broiling, always take the broiler pan out of the range and clean it when you are finished cooking. If you forget that a broiler pan was left in the range and later turn on the oven, you may start a fire.

Never use aluminum foil to line oven bottoms. Only use foil as shown on page 8 of this book. Improper use of foil could start a fire.

SELF-CLEANING OVEN ONLY

Always take the oven racks, the broiler pan and other pots and pans out of the oven before a self clean cycle.

Never use any kind of oven cleaner or oven liner coating. Do not use any spray cans near your oven. The gas used to make these cans spray can make metal parts rust in areas of high heat.

The door gasket is needed for a good seal so care should be taken not to rub or move the gasket. Clean with hydrogen peroxide. See page 11.

Always follow cleaning instructions on pages 11 and 12 of this book. Never try to clean other things in the oven during a self clean cycle unless this book tells you to.

CLOCK AND OVEN CONTROLS



TO SET THE CLOCK

1. Push the CLOCK button.
2. Turn SET knob to correct time of day. Clock is now set.

Note: To display the time of day during timed baking, push the CLOCK button. This will show the time but will not cancel any oven operation.

TO SET THE TIMER:

1. Push TIMER button.
2. Turn SET knob to desired amount of time. The Timer will immediately begin to count down.
3. When time is up, the end of cycle tone will sound.
4. To cancel the Timer, push and hold TIMER button for three seconds. This will clear the TIMER function. If the "Timer time" was being displayed, the display will go to the time of day. If the "Timer time" was not being displayed, the display will not change.

Note: The Timer is a reminder only and will not operate the oven. You can use the Timer whether or not the oven is being used. The Timer does not interfere with oven operations.

UPPER OVEN

The upper oven is operated through the Electronic Oven Control. You can bake or broil in the upper oven. You can also program bake times into the Electronic Oven Control (see To Use Timed Oven/Delay Start).

TO BAKE:

1. Push BAKE button.
2. Turn SET knob until desired temperature is displayed. The oven begins to heat within two seconds, and the display will show the temperature as it rises (in 5°F steps).
3. The Notification Tone will sound when the oven has stabilized at the selected temperature. The display will show this temperature before the tone.
4. When finished baking, push the OVEN CANCEL button.

Note: To recall what temperature you have selected while the rising temperature is being shown, push and hold the BAKE button. The selected temperature will be shown while you hold the BAKE button and will return to actual oven temperature when you release the BAKE button. You can change the selected temperature at any time by pushing the BAKE button and turning the SET knob.

TO BROIL:

1. Push BROIL button.
2. Turn SET knob until HI or LO Broil is visible in the display (see page 9).
3. When finished broiling, push the OVEN CANCEL button.

TO USE TIMED OVEN/DELAY START

Put the food in the oven and program your Electronic Range Control to turn the oven on and off. Follow instructions below.

CAUTION

Never let food sit for more than 4 hours before cooking starts, when you set your oven for a delay start. Room temperature is ideal for the growth of harmful bacteria. Be sure oven light growth.

Note: To cancel any timed oven operation, push the CANCEL button.

TO START NOW AND STOP LATER:

1. Push COOK TIME button.
2. Set length of baking time with SET knob.
3. Push BAKE button.
4. Set desired temperature with SET button.
5. When COOK TIME is reached, the end of cycle tone will sound and the oven will turn off.

TO START LATER AND STOP LATER:

1. Push COOK TIME button.
2. Set length of baking time with SET knob.
3. Push STOP TIME button.
4. Set time of day when baking should be completed with SET knob.

5. Push BAKE button.
6. Set desired temperature with SET knob.
7. When STOP TIME is reached, the end of cycle tone will sound and the oven will turn off.

Note: You can push the STOP TIME button to find out when the oven will turn off. Push and hold the COOK TIME button to find out when the oven will turn on.

When a function has been entered, you can recall what has been programmed by pushing the corresponding function button. The messages in the display show you which function is currently being displayed. While the function is displayed, you can change it with the SET knob. You can change any programmed function at any time.

Never slide the door lock/unlock handle into the LOCK position while trying to bake or broil. You will not be able to program your oven to bake or broil if the oven door is locked. If you try to lock the door while the oven is on, the oven will turn off immediately.

LOWER OVEN

The lower oven is operated through the Lower Oven control located on the left side of the control panel. You can use the lower oven while the upper oven is being used. You cannot broil in the lower oven.

TO BAKE:

1. Turn Lower Oven Control to desired temperature.
2. When finished turn Lower Oven Control to OFF.

LOWER OVEN SIGNAL LIGHT

The oven signal light will glow when the Lower Oven control is turned on and the oven is heating. When the set temperature is reached, the light will go out and then cycle on and off to show the temperature is being maintained.

TONES

End of Cycle Tone (3 long beeps - one second on, one second off): shows that a timed oven operation has reached STOP TIME or that the Timer has counted down.

Attention Tone (series of short beeps, one quarter second on, one quarter second off, until proper response is given): will sound if oven has only been partially programmed. For example, if you have selected a COOK TIME but no temperature, you will hear the attention tone until you select a temperature or push OVEN CANCEL.

Notification Tone (single, one second beep): shows that the oven has stabilized at the selected temperature.

Keytone (single, one tenth second beep): sounds when any button is pushed.

Failure Tone (series of very rapid beeps, one eighth second on, one quarter second off): display will show F0-F8. Cancel failure tone by pushing the OVEN CANCEL button. If the failure occurred while you were programming the Electric Range Control, push the OVEN CANCEL button and try again. If you still get a failure tone that does not stop after 16 seconds, call for service. If you are unable to cancel the failure tone with the OVEN CANCEL button, unplug the range or disconnect the circuit breaker.

If you prefer that your range not have an audible tone at the end of a cycle or when you push a button (Key Tone), you can eliminate the End of Cycle and Key Tone by pushing and holding the OVEN CANCEL button until you hear a short beep (in approximately two seconds). If you wish to activate the tones again, push and hold the OVEN CANCEL button once more until you hear a short beep. Cancelling or activating the tones should only be done when there is no oven operation programmed. Pushing the OVEN CANCEL button will clear all functions except the clock and Timer.

OVEN LIGHT

The oven light switch is located on the left side of the control panel. See page 16 for more information.

OVEN VENT

When the oven is on, heated air moves through a vent below the control panel.

The vent area could get hot during oven use.

The vent is needed for proper air flow in the oven and good baking results. Do not block this vent. Doing so may cause cooking failure, fire or damage to the oven.

NEW OVEN ODOR

During the first baking and broiling cycles of your new oven, there may be some odor. This is normal and is caused by the heating of new parts and insulation. The odor will go away within a short time. A vent fan or other ventilation will help to clear the way.

PREHEATING

Preheating lets the oven heat evenly before the food is put in. Allow 10 minutes at temperature less than 350°F and about 15 minutes at temperatures of 350°F or more.

With recipes that call for an oven preheated to a certain temperature. It is very important that you follow those instructions. It is not likely that you will get good baking results every time without preheating to the needed temperature unless the recipe says to start in a cold oven.

After the oven is preheated and you are ready to put the food in, try to have everything handy so that you will not have to leave the oven door open for an extended period of time.

Opening the door to check the food during baking makes it impossible for the oven to stay at the temperature you have selected. Try to time your baking and check only when close to being finished.

NOTE: When using cookware made of ovenproof glass or pottery, Teflon coated cookware or dull or darkened pans in the oven, be sure to reduce recipe temperature by 25°F (see Choosing Cookware Chart, page 10).





RACK AND PAN ARRANGEMENT

Put oven rack(s) in place before turning on the oven. Rack positions are numbered 1 to 4, starting at the bottom with number 1. In general, when using only one rack, position No. 2 should be used. When using two racks, positions No. 2 and No. 4 work best.

When using cookie sheets, place them with the long side toward the front of the oven and centered on the rack. When using two cookie sheets at the same time use rack positions No. 2 and 4. The cookies on the lower rack may be done 1-2 minutes before the ones on the higher rack. You may want to switch rack positions when baking is halfway finished.

Pans too close to each other, to oven walls or to the oven bottom block the free movement of air. Improper air movement causes uneven browning and cooking.

Normally there should be 1½ to 2 inches of air space on all sides of each pan in the oven. See tips below.

<p>When using a large flat pan that covers most of the rack, center on one rack.</p>  <p>Sheet Cakes, Cookies, Biscuits</p>	<p>When baking a sponge or angel food cake, center on one rack in the lowest position.</p>  <p>Angel Food or Sponge Cake</p>
<p>The pan or pans using the least amount of rack area should be placed on the lower of the two racks.</p>  <p>Cake Layers, Pies, Casseroles, 3 pans</p>	<p>When using two racks and several pans, stagger them so no pan is directly above another.</p>  <p>Cake Layers, Pies 4 Pans (staggered)</p>

USING FOIL

For Baking

To catch spillovers, cut a piece of foil slightly larger than the pan and turn up the edges. Use two oven racks and put the foil on the lower oven rack below the pan. Do not use aluminum foil directly under a pan on the same oven rack. The foil will not reflect heat away from the pan.



Do not cover the oven bottom or an entire oven rack with foil. The foil can block normal heat flow, cause cooking failures, and damage the oven interior.

For Roasting

For slow browning, place a foil "tent" loosely over the meat. This is especially good on a large turkey. The "tent" lets oven heat circulate under the foil. Sealing the foil will tend to steam the meat.

To reduce spattering, lightly crush foil and put it in the bottom of the pan under the food.

For Broiling



Do not cover the entire broiler grid with foil. Poor drainage of hot fat may cause a broiler fire. If a fire starts, close the oven door and turn controls off. If fire continues, throw baking soda on the fire. Do not put water or flour on the fire. Flour may be explosive.

BROILING TIPS

- **Your oven door should be open to the stop position while broiling (See page 14).** If the door is closed, the food will roast and not broil.
- Use only the broiler pan and grid furnished with your range for broiling. They are designed for proper drainage of fat and liquids and help prevent spatter, smoke or fire.
- **Do not preheat** when broiling. For even broiling on both sides start the food on a cold pan. Allow slightly more than half the cooking time for the first side then turn the food using tongs. If you pierce the meat with a fork, the juices will escape.
- When broiling frozen meats, use one rack position lower than recommended up to 1½ times the suggested broiling time.
- Trim the outer layer of fat from steaks and chops. Slit the fatty edges to keep the meat from curling.
- Always put the food being broiled on the proper rack (see chart at right). Food placed too close to the broiler may spatter, smoke or catch fire.
- For maximum juiciness, salt the first side just before turning the meat. Salt the second side just before serving.
- Brush chicken and fish with butter several times as they broil. When broiling fish, grease the grid to prevent sticking and broil with skin side down. It is not necessary to turn fish.
- **Never leave a soiled broiler pan in the range.** Grease in the pan may smoke or ignite the next time oven is used. See page 13 for tips on cleaning the broiler pan and grid.

POSITIONING BROILER PAN (upper oven only)

Broiling is cooking by direct heat from the upper oven element. Tender cuts of meat or marinated meat should be selected for broiling. For best results steaks and chops should be at least ¾" thick.

After placing food on the broiler pan, put the pan on an oven rack in the proper position. The recommended rack position and cooking time can be found in the chart at right.

Most foods can be broiled on the HI setting. Select the LO broil setting to avoid excessive browning or drying of foods that should be cooked to the well done stage (such as thick pork chops or poultry). The closer the food is to the broil element the faster the meat browns on the outside, yet stays red to pink in the center. Moving the meat farther away from the element lets the meat cook to the center while browning outside.

Food	Rack Position 4 = Highest 1 = Lowest	Total Times (Minutes)
Steak - 1" Thick Rare Medium Well Done		
	4	9-11
	3	13-15
	3	21-23
Ground Beef Patties Medium - 1" Thick Medium - ½" Thick	3	16-18
	4	7-9
Lamb Chops - 1" Thick	3	18-21
Pork Chops - 1" Thick	3	27-29
Pork Chops - ½" Thick	3	16-18
Ham Slice - ½" Thick	3	11-12
Fish (Filets)	3	11-13
Chicken (Pieces)	2	45-55
Frankfurters	3	8-11
Bacon	3	9-11

This chart is a general guide. The size, weight, thickness and starting temperature of the food, as well as your own personal preference, will affect the cook time.

OVEN COOKWARE	
Aluminum	Absorbs heat faster than glass or steel and conducts heat well. Produces delicate browning, tender crust, and reduces spattering of roasts. Best for cakes, muffins, quick breads, cookies, and roasting.
Ovenproof Glass/ Pottery	Because this cookware absorbs heat quickly and holds it well, you should lower your oven temperature 25°F. Gives food a deep, crusty brown top. Best for casseroles.
Teflon, Dull or Darkened Cookware	Absorbs heat quicker than shiny cookware. Lower your oven temperature 25°F (except for pastry). Good for pies and other foods baked in pastry shells.

COMMON BAKING PROBLEMS AND CAUSES

CAKE RISES UNEVENLY

- Range or oven rack not level
- Pan warped
- Batter spread unevenly in pan
- Pans too close to oven wall or rack too crowded

CAKE HIGH IN MIDDLE

- Too much flour
- Oven temperature too high

CAKE NOT DONE IN CENTER

- Wrong size pan
- Oven too hot
- Pan not centered in oven

CAKE FALLS

- Too much shortening, liquid or sugar
- Temperature too low
- Pan too small
- Oven door opened too often
- Too much leavening or stale leavening
- Overmixing after adding flour

BOTTOM PIE CRUST SOGGY

- Filling too juicy
- Filling allowed to stand in pie shell before baking
- Used shiny pans
- Temperature too low at start of baking
- Crust and/or filling not allowed to cool before filling crust

BURNING AROUND EDGES OF PIE CRUST

- Oven temperatures too high
- Edges of crust too thin or too high
- Oven too full or pans too close together

COOKIES AND BISCUITS BURN ON BOTTOM

- Oven preheat time too short
- Pan too deep or too large
- Used dark pans
- Used incorrect rack position

FOOD NOT DONE AT END OF COOKING TIME

- Oven temperature set too low
- Oven too crowded
- Oven door opened too often
- Aluminum foil blocking air movement

THE SELF-CLEAN CYCLE (upper oven only)

1. Remove the broil pan and grid, oven racks, all utensils and any foil that may be in the oven. If oven racks are left in the range during a clean cycle, they will darken, lose their luster and become hard to slide.
2. Soil on the oven front frame, under the front edge of the cooktop, the door liner outside the door seal and the front edge of the oven cavity (about 1" into the oven) will not be cleaned during a clean cycle (see illustration below). Clean these areas by hand before starting a clean cycle.

Use detergent and hot water with a soap-filled steel wool pad, then rinse well with a vinegar and water mixture. This will help prevent a brown residue from forming when the oven is heated.

Before A Clean Cycle

3. Wipe up heavy spillovers on the oven bottom. Too much soil may cause smoking during the clean cycle.
4. Clean the door seal by using a clean sponge to soak the soiled area with hydrogen peroxide. Repeated soaking may be needed depending on the amount of soil. Frequent cleaning will prevent excessive soil build up. Do not rub the door seal excessively. The fiberglass material of the seal has an extremely low resistance to abrasion. Any cotton material especially (including cottonballs), can easily rub a hole into the seal. Do not use any cotton materials to clean the seal. An intact and well fitting oven door seal is essential for energy efficient oven operation and good baking results. If you notice the seal becoming worn, frayed or damaged in any way or if it has become displaced on the door you should replace the seal.

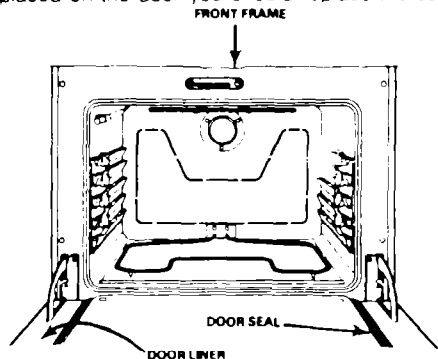

DO NOT use commercial oven cleaners or oven protectors in or near the oven. These products plus the high temperature of the clean cycle may damage the porcelain finish.

DO NOT clean glass ceramic cookware or any other cookware in the oven during a self-clean cycle.

IMPORTANT INFORMATION

All controls must be set correctly for the clean cycle to work properly. To help you understand how the clean cycle works, the stages of the cycle are noted below.

1. The controls are set.
2. The word CLEAN will be on in the display, the oven begins to heat and the door locks automatically.
3. For your safety the oven door can not be opened (the word LOCK will be on in the Electronic Range Control display.)
4. When the 3½ hour clean cycle is over the word CLEAN will be off in the display the oven begins to cool.
5. When the temperature has fallen below locking temperature the door can be opened (the word LOCK will be off in the display).

After a cleaning cycle, the oven door cannot be unlocked unless: The temperature has had time to drop to a safe level and the word LOCK is off in the Electronic Range Control display.

TO SET A CLEAN CYCLE

The self-cleaning cycle is preprogrammed for 3½ hours. You can also set the electronic range control for a delayed start of the clean cycle.

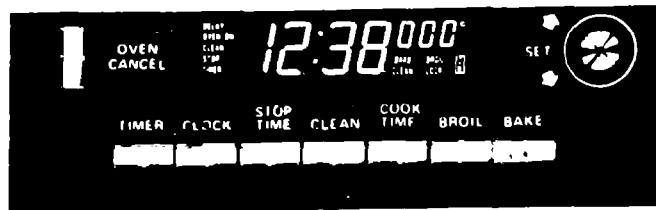

To self-clean:

1. Push the CLEAN button.
2. Turn SET knob in the clockwise direction about ½ turn.

The word CLEAN will be on in the display.

NOTE: You can find out when the clean cycle will be finished by pushing the STOP TIME button.

To use delayed self-clean:

1. Push STOP TIME button
2. Turn SET knob to time of day when you wish cleaning to be completed (must be more than 3½ hours later than current time of day).
3. Push the CLEAN button.
4. Turn SET knob in the clockwise direction about ½ turn.

The words DELAY CLEAN will be on in the display until the clean cycle starts. After the clean cycle starts the word CLEAN will be on in the display.

Note: During a delayed self-clean operation you can find out when the oven turns on by pushing and holding the CLEAN button.

TO STOP A CLEAN CYCLE:

1. Press the OVEN CANCEL button.
2. Wait until the oven has cooled below locking temperature and the word LOCK is off in the display.

You will not be able to open the door unless the oven temperature is at a safe level. If you cannot open the oven door immediately after the word LOCK goes off, wait about one minute and try again.

WHEN A CLEAN CYCLE IS FINISHED

1. When a clean cycle is finished the word CLEAN will be off in the display.
2. Wait until the oven has cooled below locking temperature and the word LOCK is off in the display.

You will not be able to open the door unless the oven temperature is at a safe level. If you cannot open the oven door immediately after the word LOCK goes off, wait about one minute and try again.

AFTER A CLEAN CYCLE

After a clean cycle, you may notice some white ash in the oven. Just wipe it up with a damp cloth.

If white spots remain, remove them with a soap-filled steel wool pad. Be sure to rinse thoroughly with a vinegar and water mixture. These deposits are usually a salt residue that can not be removed by the clean cycle.

If the oven is not clean after one clean cycle, the cycle may be repeated.

PART	CLEANING INSTRUCTIONS	
Control Panel	Wash control panel with soap and water . Do not use abrasive cleaners .	
Outside Finishes: Chrome	Wash with soap and water . A chrome cleaner may be used.	
Glass (some doors)	Wash with a soapy damp cloth. Remove stubborn soil with a paste of baking soda and water or ammonia and water . Do not use abrasive materials . Before using an all-purpose cleaner , check the label to be sure it is recommended for glass —some will	permanently damage glass . To help prevent a brown residue from forming on the oven window the next time the oven is heated, rinse the inside of the window with vinegar and water , then dry.
Paint (some doors)	Wash with soap and water , rinse then dry with a paper towel. Avoid cleaning powders or abrasives which may	scratch the surface .
Oven Finishes: Porcelain (lower oven)	Wash with soap, water and a scouring pad . Soak stubborn stains with an ammonia soaked paper towel, or set a dish of ammonia water in the oven overnight to loosen soil, then rub with a scouring pad . Rinse thoroughly. When using oven cleaners , follow package directions and be sure that no traces of the oven cleaner remains in the	oven . Traces of the cleaner could put stains on the finish when heated. To make sure this does not happen give a final rinse of vinegar and water . Caution: Do not coat heating element and thermostat bulb (in upper part of oven) . Never use oven cleaner on outside oven surfaces, aluminum, chrome or baked enamel.
	Use soap, water and a scouring pad for touch up cleaning between self-cleaning cycles and rinse thoroughly.	Avoid any contact with the oven door seal (see below) . Avoid all oven cleaners .
Oven Door Seal (self-cleaning ovens)	Soak soiled area with hydrogen peroxide (see page 11) .	
Oven Racks	Remove from oven (see instructions on page 15) and wash at sink with soap, water and a scouring pad . If oven	racks are left in oven during a clean cycle, wipe edges with vegetable oil so they slide in and out easier.
Broiler Pan and Grid	Do not leave in oven to cool. If you soak immediately, clean-up will be easier. Remove pan from oven and remove fat and drippings. Sprinkle pan with detergent then cover with a wet cloth or paper towel and let soak.	Later wash in soap and water using a scouring pad as necessary. Both the pan and grid are dishwasher safe.

REMOVABLE OVEN DOOR(S) (models without removable rack guides)

The oven door can be removed for cleaning.

To remove:

1. Open the door to the stop position (see illustration)
2. Grasp the door at each side and lift up and off the hinges

See the cleaning chart on page 13

NOTE: When the door is removed and hinge arms are at stop position, do not bump or try to move the hinge arms. The hinges could snap back causing an injury to the hands or damage to the porcelain on the front of the range. Cover the hinges with toweling or empty towel rolls while working in the oven area.

To replace:

1. Hold the door over the hinges with the slots at the bottom edge of the door lined up with the hinges. **The hinge arms must still be in the stop position.**
2. Slide the door down onto the hinges as far as it will go and close the door.

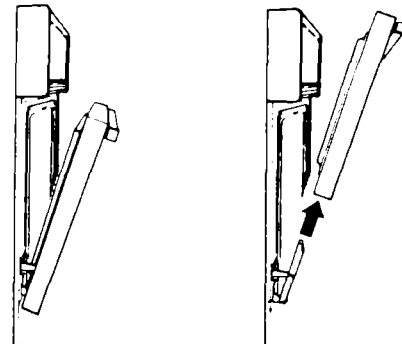

STOP POSITION

REMOVABLE OVEN DOOR(S) (models with removable rack guides)

The oven doors can be removed for cleaning.

To remove:

1. Open the door to the broil stop position and grasp the door at each side (see illustration).
2. Lift the door up a bit, then pull straight toward you.

To replace:

1. Make sure that hinge arms are in position B (broil stop position).

Note: If a hinge arm snaps into position A, it must be moved back to position B before the door can be replaced.

2. Carefully insert the hinge arms through the openings in the front frame and push the door into place while holding the door up.
3. When the bottom edge of the door is flush against the front frame, allow the door to settle into place.

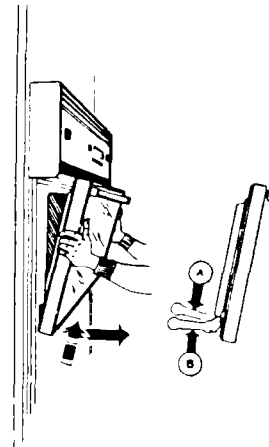

REMOVABLE OVEN RACKS AND GUIDES (some models)

Be sure not to scratch the oven finish when installing or removing oven racks.

To install:

1. Put the pegs on the end of the rack guide into the holes in the oven back.
2. Lock the front hook in the slot in the oven side.
3. Set the raised back edge of the oven rack on a pair of rack guides so the hooks at the sides of the rack run underneath the rack guides.
4. Push the rack in until you reach the bump in the rack, then lift the front of the rack a bit and push the rack all the way in.

To remove:

1. Pull the oven rack out, then up, in one motion.
2. Lift the front of the rack guide to unhook it from the oven wall and pull out.

See the cleaning instructions on page 13.

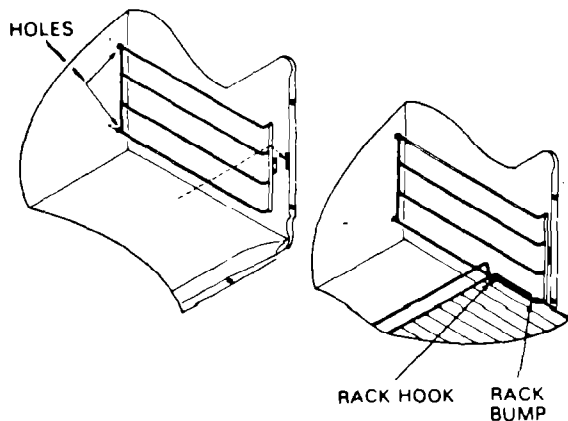

REMOVABLE OVEN RACKS (some models)

Be careful not to scratch the oven finish when installing or removing the oven rack.

To install:

1. Set the raised back edge of the rack on a pair of rack guides.
2. Push the rack in until you reach the bump in the rack guide, then lift the front of the rack a bit and push the rack all the way in.

To Remove:

1. Pull the oven rack out, then up.

See the cleaning chart on page 13.

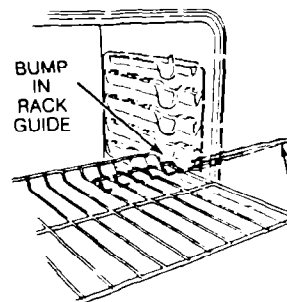

REPLACING THE OVEN LIGHT (Some Models)

Do not touch oven bulb when hot, with wet hands, or wipe oven light area with wet cloth. Unplug or disconnect the electrical supply to range before removing.

Never touch the electrically live metal collar on the bulb when replacing it.

Electrical power *must* be shut off if you have to replace a broken bulb.

UPPER SELF-CLEANING OVENS

1. Remove the three screws and lift off the glass retainer, glass cover and gasket.
2. Replace the bulb with a 40 watt appliance bulb.
3. Replace the gasket, glass cover and glass retainer. Tighten screws securely.

LOWER NON-SELF-CLEANING OVENS:

Replace bulb with a 40 watt appliance bulb.

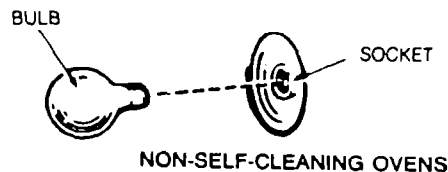
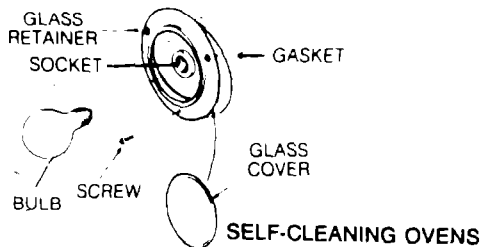

REMOVABLE LOWER OVEN CONTROL KNOB

All control knobs may be removed for easy cleaning by pulling the knob straight off the stem.

See the cleaning chart on page 13.

Caution: Read these instructions carefully before replacing the knobs. Replacing the knobs improperly will damage the knobs and the spring clip on the stems. If this happens, the knobs will fit loosely.

To correctly replace knobs:

1. Look at the stem. It has a groove in each side. The groove on one side has a spring clip, the other groove is clear (see illustration).
2. Check the inside of the knob and find the molded rib.
3. Replace the knob by fitting the molded rib inside the knob into the clear groove on the stem.

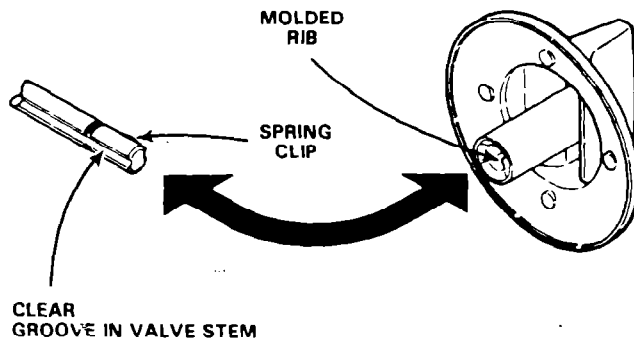

ADJUSTING OVEN TEMPERATURE

The temperature in your new oven has been set correctly at the factory, so be sure to follow the recipe temperatures and times the first few times you bake in your new oven.

If you think the oven should be hotter or cooler, you can adjust it yourself. To decide how much to change the temperature, set the oven temperature 25°F higher or lower than the temperature in your recipe, then bake. The results of this "test" should give you an idea of how much the temperature should be changed.

To adjust upper oven temperature:

1. Push the BAKE button.
2. Select a temperature between 500°F and 550°F with the SET knob.
3. Quickly (within two seconds, before the BAKE function energizes) push and hold the BAKE button.
The display will go blank and then will show the amount of degrees difference between the original factory temperature setting and the current temperature setting. If the oven temperature has never been adjusted the display will read 00.
4. The temperature can be adjusted up to 35°F hotter or 35°F cooler, in 5°F steps. A minus sign (-) before the number means that the oven will be cooler by displayed amount of degrees.
5. When you have made the desired adjustment, push the CLOCK button to go back to the time of day display or use your oven as you would normally.

Note: The self-clean temperature will not be changed by above described adjustment.

To adjust lower oven temperature:

1. Turn OVEN TEMP knob to OFF and remove the knob by pulling straight off.
2. Look at the back of the knob. The arrow pointing to the center of the upper screw indicates the original factory setting. The knob can be adjusted up to 50° hotter or 50° cooler, in 10° increments.
3. Use a screwdriver to loosen the two screws about 1 turn each.

4. Hold the knob handle (A on illustration) while turning the knob skirt (B on illustration) in the desired direction. As you turn you should be able to hear clicks and feel notches or teeth. Each click or notch is 10°. You can turn up to 5 clicks or notches in either direction.
5. When you reach the desired adjustment, retighten both screws.
6. **IMPORTANT:** Before you replace the OVEN TEMP knob, carefully read the instructions for replacing the knob (on page 16). Do not force the knob onto the thermostat stem or you may damage it.

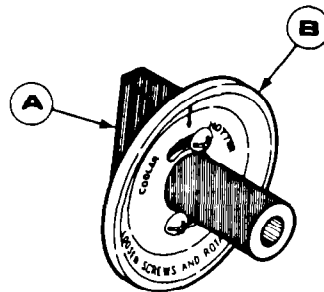

MAKES OVEN HOTTER
(Screw Moved Toward Hotter)

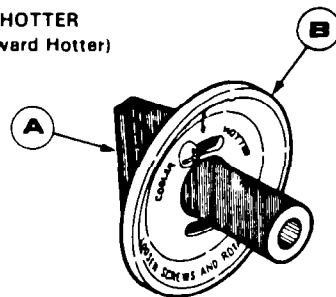

MAKES OVEN COOLER
(Screw Moved Toward Cooler)

IF YOU HAVE A PROBLEM

Save time and money — check this list before you call for service. To eliminate unnecessary service calls, first read all the instructions in this manual carefully. Then, if you have a problem, always check this list of common problems and possible solutions before you call for service. If you do have a problem you can not fix yourself, call your authorized Dealer for help.

ELECTRONIC OVEN CONTROL DOES NOT WORK

- Check to be sure oven cord is plugged into outlet completely. Check for a blown fuse or tripped circuit breaker.
- Check for power outage.
- Check step by step operating instructions on pages 5 or 6.
- Check for blown fuse or tripped circuit breaker.

OVEN IS BEEPING

- See the section on tones on page 7.

OVEN DOES NOT WORK

- Check to be sure oven cord is plugged into outlet completely. Check for a blown fuse or tripped circuit breaker.
- Check for power outage.
- Is the Lower Oven Control turned on if trying to use lower oven?
- Electronic Oven Control not set correctly. See pages 5 and 6.

OVEN GIVES OFF AN ODOR

- See the section on new oven odor on page 7.

BROILING PROBLEMS

- Electronic Range Control not set to Broil (see pages 5 or 6).
- Using wrong rack position. See chart on page 9.
- Aluminum foil not used properly and grease can not drain correctly. See page 8.
- You cannot broil in lower oven.

OVEN/BROILER SMOKING

- Broiler pan full of grease left in range from the last time you broiled food. Dirty broiler pan must not be left in the range or smoking and a broiler fire can result the next time the oven is used.
- Aluminum foil not used properly and grease can not drain correctly. See page 8.

COOKING RESULTS ARE NOT WHAT YOU EXPECTED

- Are you using a tested recipe from a reliable source? Are you following all the instructions in the recipe, such as pan size, preheating, using all ingredients called for?
- Oven too crowded, or using wrong rack position. See pages 8 and 10 for tips.
- Electronic Oven Control not set correctly. See pages 5 or 6 for step by step instructions.
- Using improper cookware. See tips on page 10.
- Check the section on baking problems and causes on page 10.

OVEN LIGHT WILL NOT WORK (Some Models)

- Check for power outage.
- Check for loose or burned out bulb. See page 16 for replacement instructions.
- Check for blown fuse or tripped circuit breaker.

UPPER OVEN WILL NOT SELF-CLEAN (Some Models)

- Electronic Oven Controls not set properly. Review step by step instructions on page 12.
- If oven went through clean cycle but did not get clean, oven was too dirty and should be cleaned more often. Heavy spillovers were not wiped before starting clean cycle. See page 11.
- Lock handle not in correct position. See page 12.

UPPER OVEN DOOR WILL NOT UNLOCK AFTER SELF-CLEAN CYCLE (Some Models)

- The oven has not cooled to the unlocking temperature. The door can not be opened until the temperature drops to a safe level. See pages 11 and 12.