

SERVICE DATA SHEET

218758400

STANDARD - AUTOMATIC DEFROST

TOP FREEZER MODELS

PERFORMANCE DATA NO LOAD AND NO DOOR OPENINGS AT MID-POINT CONTROL SETTING					
Type A With Run Capacitor	Type B With No Capacitor	65°F Ambient		90°F Ambient	
		Type A	Type B	Type A	Type B
Operating Time		30 to 45%	35 to 45%	54 to 65%	55 to 67%
Freezer Temperature		0° to 8°F	0° to 6°F	0° to 6°F	0° to 6°F
Refrigerator Temperature		35° to 40°F	35° to 40°F	35° to 40°F	35° to 40°F
Low Side Pressure (cut-in)		6 to 13 psig	6 to 9 psig	6 to 13 psig	6 to 9 psig
Low Side Pressure (cut-out)		-2 to +2 psig	-2 to +2 psig	-2 to +3 psig	-2 to +2 psig
High Side Pressure - PSIG (Last 1/3 of cycle)		105 to 115	105 to 115	160 to 185	160 to 185
Wattage (Last 1/3 of cycle)		150 to 200	190 - 220	150 to 200	190 - 220
Amps (Running)		1.3 to 1.8	2.2 to 2.6	1.3 to 1.8	2.2 to 2.6
Base Voltage		115 VAC	115 VAC	115 VAC	115 VAC
DEFROST SPECIFICATIONS					
Cabinet Size	Thermostat		Heater		
	Cut-in	Cut-out	Watts	Ohms	
13' to 17'	+25°F	+47°F	400	33	
18'	+25°F	+47°F	475	28	
Defrost 21 Minutes Every 8 Hours of Compressor Run Time					
CONDENSER FAN MOTOR					
Watts	RPM	Amps			
2.3	1300 CW Opposite Shaft	.15 Running			
THERMOSTATIC DAMPER					
	Full Open	Closed			
	33°F +/- 2°F	22°F +/- 2°F			
ICE MAKER SPECIFICATIONS					
Electrical	115 Volts	60 Hertz			
Thermostat	Opens at 48°F	Closes at 15°F			
Heater Wattage	165				

IMPORTANT SAFETY NOTICE

The information provided herein is designed to assist qualified repair personnel only. Untrained persons should not attempt to make repairs due to the possibility of electrical shock. Disconnect power cord before servicing.

IMPORTANT

If any green grounding wires are moved during servicing, they must be returned to their original position and properly secured.

CAUTION: System parts must be removed from cabinet before brazing. All electrical parts and wiring must be shielded from torch flame. Do not allow torch to contact insulation; it will char at 200°F and flash ignite (burn) at 500°F. Excessive heat will distort the plastic liner.

ICE MAKER INFORMATION

Test Cycling

Remove cover by inserting screwdriver in notch at bottom and prying cover from housing. Use a screwdriver to rotate motor gear counter-clockwise until holding switch circuit is completed. All components of ice maker should function to complete the cycle.

Water Fill Volume

The water fill adjustment screw will change the fill time. One full turn is equal to 20cc (.68 oz.). The correct fill is 90 to 120cc (3.0 to 4.0 oz.). When a water valve is replaced, the fill volume must be checked.

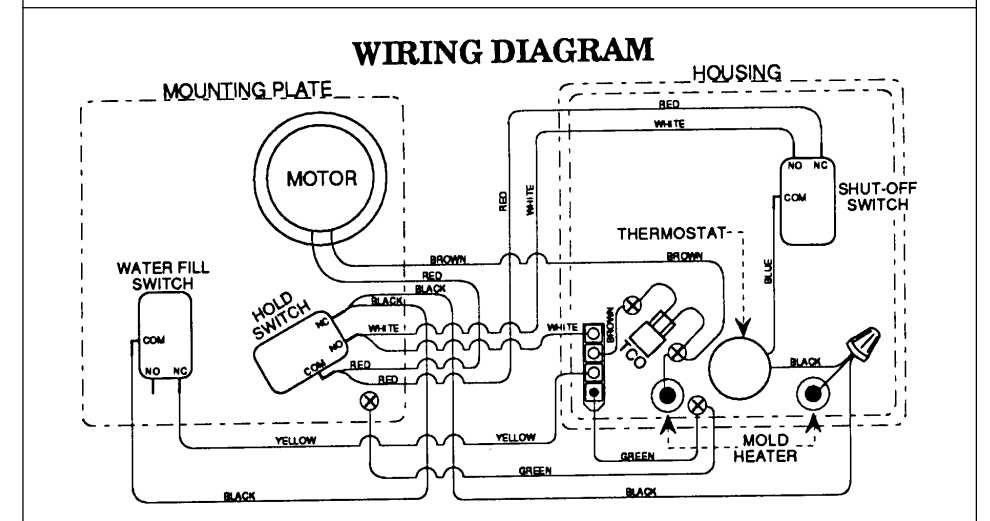
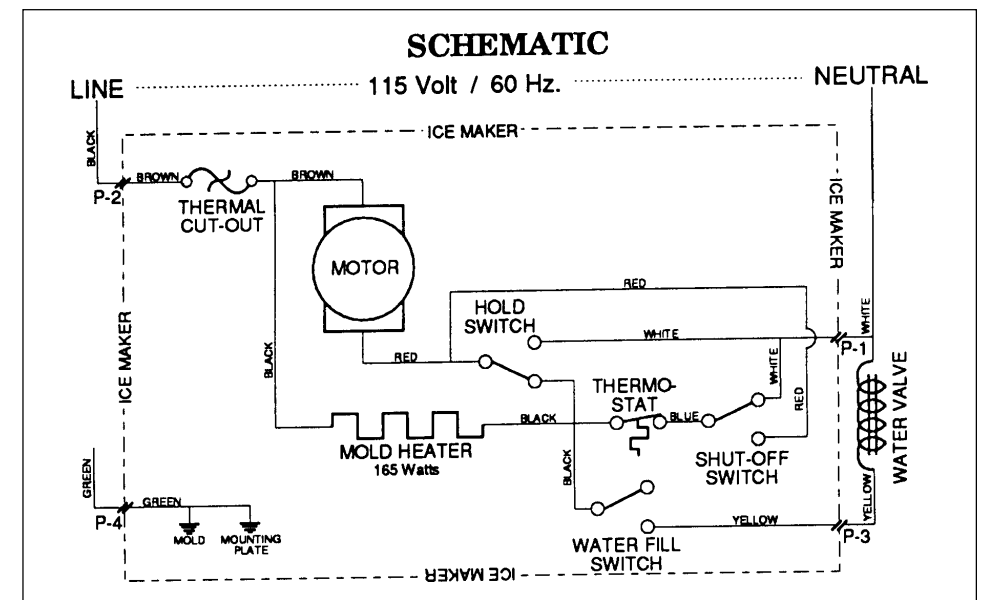
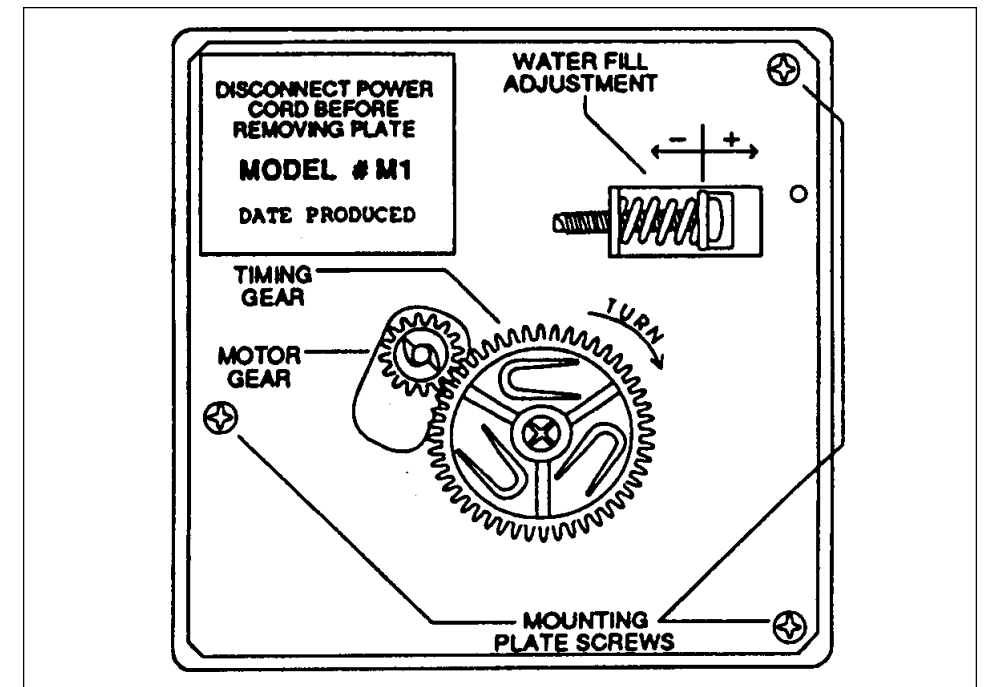

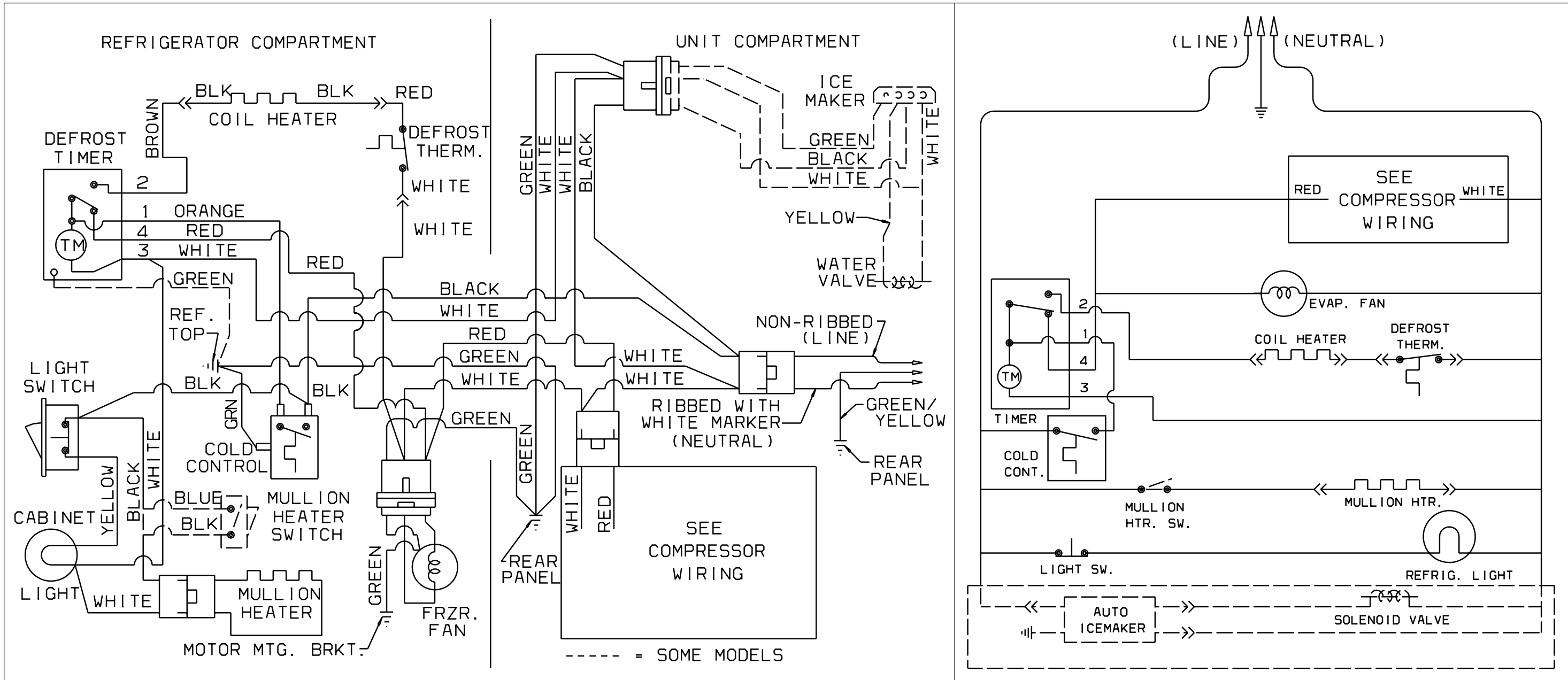

P.T.C. RELAY WITH RUN CAPACITOR

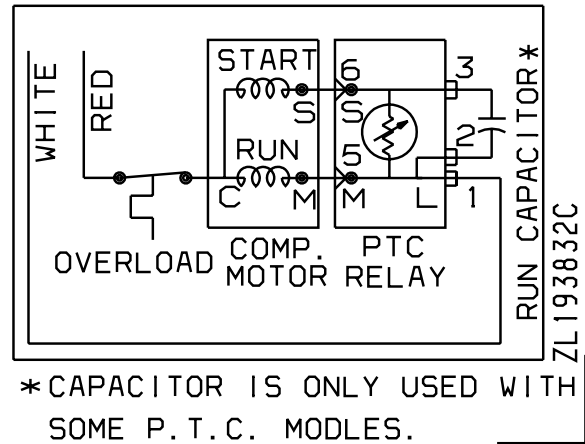

COMPRESSOR WIRING

