

PERFORMANCE DATA NO LOAD & NO DOOR OPENINGS AT 37°/0° CONTROL SETTING		
Type A with Run / Start Capacitor	65°F (18°C) Ambient	90°F (32°C) Ambient
Operating Time	90 to 100%	100%
Freezer Temperature	-5° to 2°F (-20° to -17°C)	-1° to 3°F (-18° to -16°C)
Refrigerator Temperature	34° to 39°F (1° to 4°C)	34° to 39°F (1° to 4°C)
Low Side Pressure	-2 to 6 psig (-14 to 41 kPa)	-2 to 6 psig (-14 to 41 kPa)
High Side Pressure (last 1/3 cycle)	85 to 105 psig (586 to 724 kPa)	120 to 135 psig (827 to 931 kPa)
Wattage (last 1/3 cycle)	30 to 50	50 to 70
Amps (running)	.4 to .8	.7 to .9
Base Voltage	115 vac (127 vac max)	

DEFROST SPECIFICATIONS					
Cabinet Size: 27' & 28' SD, 22' CD	Thermal Cutout		Heater		Defrost Thermistor Termination
	Cut-in	Cut-out	Watts	Ohms	Cut-out
	110°F (43.3°C)	135°F (57.2°C)	500	26.5	39°F (4°C)

Electronic Timer - (ADC) Defrost 24 minutes every 6-96 hours of compressor run time.

CONDENSER FAN MOTOR		
Watts	RPM	Amps
3.1	1100 CW Opposite Shaft	0.03 Running

FREEZER ICE MAKER SPECIFICATIONS	
Electrical	115 vac (127 vac max)
Thermostat	Opens at 48°F (9°C), Closes at 15° F (-9°C)
Heater Voltage	115 vac

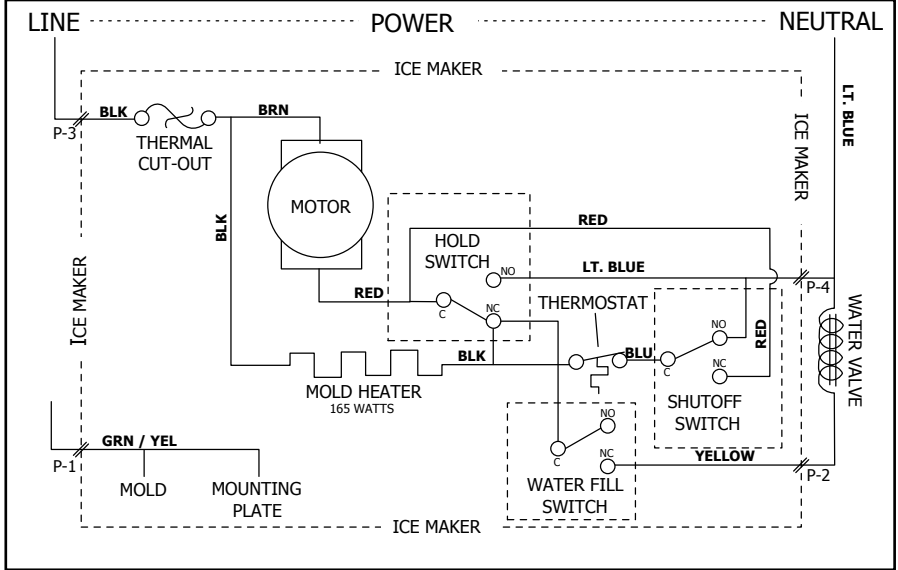

CAUTION
All electrical parts and wiring must be shielded from torch flame. DO NOT allow torch to touch insulation; it will char at 200°F and flash ignite (burn) at 500°F. Excessive heat will distort the plastic liner.

FREEZER ICE MAKER INFORMATION
(Where Applicable)
Test Cycling: Remove cover by inserting screwdriver in notch at bottom and prying cover from housing. Use screwdriver to rotate motor gear counterclockwise until holding switch circuit is completed. All components of ice maker should function to complete the cycle.
Water Fill Volume: The water fill adjustment screw will change the fill time. One full turn is equal to 20cc (.68 oz.). The correct fill is 102 to 130cc (3.4 to 4.3 oz.). When a water valve is replaced, the fill volume must be checked.

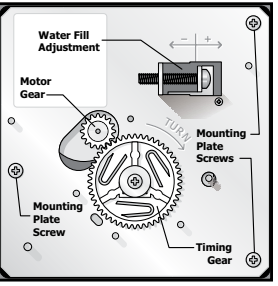

SERVICE DATA SHEET

A01544202

ICE & WATER - AUTOMATIC DEFROST

BOTTOM FREEZER - R134a

IMPORTANT: PLEASE RETURN THIS SHEET TO ITS ORIGINAL LOCATION.

ERROR CODES		SPECIAL MODES			
Display	Interpretation	Mode	Display		Activate/Deactivate (press for up to 10 sec. simultaneously)
FZ	FF		FZ	FF	
--	OP	Open FF Thermistor	d	F	FF UP and FF DOWN / same to deactivate
OP	--	Open FZ Thermistor	77	77	FZ UP and FF DOWN / Power-on-Reset (POR)
--	SH	Shorted FF Thermistor	Sb	Sb	FZ DOWN and FF UP / same to deactivate
SH	--	Shorted FZ Thermistor	No FF or FZ display, all UI LEDs on.		FZ UP and FZ DOWN / FF UP to deactivate
SY	CF	UI to Main Control Board communication failure; on start up	Numerical display of first test		FZ UP and FF UP together to activate / press and hold FF UP to deactivate
SY	CE	UI to Main Control Board communication error; after a period in operation	Notes: • Always check for pin back-outs, pinched or damaged wires before replacing components. • Determine whether failure is caused by the component, main control board or wiring. Contact TID before replacing main control board. • Refer to Service Manual for additional information.		
SY	EF	Evaporator Fan Failure			

FRESH FOOD ICE MAKER DIAGNOSTIC MODE			
Activate:	Press FZ UP and FF UP temperature pads for up to 10 sec. simultaneously. Press FF UP or FF DOWN to move forward or backward through tests.		
Deactivate:	Press FF UP for up to 10 sec. FFIM Diagnostic Mode will automatically deactivate after 5 min. of inactivity. NOTE: Silence alarm.		
Test	To activate test	Passing Result	
52C	Ice Maker Thermistor	Activates automatically	FZ display shows temperature sensed by Ice Maker Thermistor. "OP" if open; "SH" if short
55C	Water Valve	Press power on-off	Remove ice tray to collect water into a measuring container to measure water fill. If collecting water into ice tray, first perform test 63C to empty ice tray.
57C	Evaporator Fan (FFIM)	Press power on-off	"On" on FZ display when fan activated, "OFF" when deactivated.
58C	Ice Level Sensor	Activates automatically	Remove ice bucket. Allow bail arm to drop freely. Pass if no alarm when tray returns to "home" position. Hold bail arm up. Pass if alarm sounds when tray returns to "home" position. This test runs continuously until another test is selected.
63C	Twist Tray	Press power on-off	Remove ice bucket. FZ display shows "1" and "GOOD".

Variable Capacity Compressor (VCC) Diagnostics (select models)

If test 38 fails, diagnose as follows:

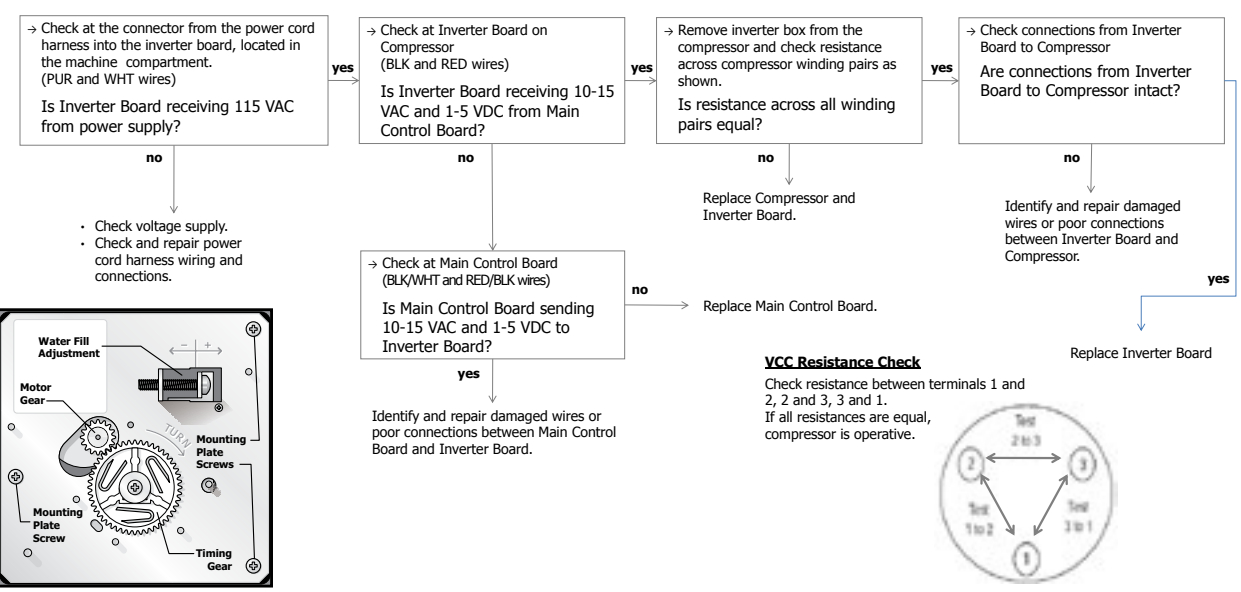

SYSTEM DIAGNOSTIC MODE			
Activate:	Press FZ UP and FZ DOWN for up to 10 sec. simultaneously. Press FF UP to advance through tests.		
Deactivate:	Press FF UP for up to 10 sec. Diagnostic Mode will automatically deactivate after 5 min. of inactivity. Note: Silence alarm.		
<ul style="list-style-type: none"> Tests marked with "*" may not be applicable to this unit and will not be displayed in System Diagnostic Mode. Tests displayed in diagnostic mode but not described below are for internal purposes only; advance through. View UI display for "on," "off," "CL," "OP," "SH," "LO," "HI" or numerical results of tests. Listen for operating sounds; feel for heat or air flow as appropriate to determine results of tests. 			
	Test	To activate test:	Passing result
--	First Screen	--	Blank UI display, no lights illuminated, no shadowing.
--	Second Screen	--	All LED lights on UI illuminated.
--	Third Screen	--	Blank UI display, no lights illuminated, no shadowing.
28	Dispenser Paddle	Press disp. paddle	"on" on UI when depressed; "off" when released
2	Freezer Defrost Heater	Press power on-off	Freezer defrost heater on when "on"; off when "off".
3	FF Light	Press power on-off	FF lights on when "on"; off when "off"
8	Water Valve (Dispenser)	Press power on-off	FF door must be closed. Be prepared to collect water at dispenser. Water dispenses when "on"; stops when "off"
9	FZ Light	Press power on-off	FZ lights on when "on", off when "off"
10	Auger Motor	Press power on-off	FF door must be closed. Motor running when "on"; motor stopped when "off"
11	Cube/Crush Solenoid	Press power on-off	FF door must be closed. Do not leave solenoid in activated state. Solenoid activated when "on"; deactivated when "off".
12*	VCC Condenser Fan	Press power on-off	Fan running when "on"; stopped when "off"
41*	Perfect Temp Drawer (PTD)	Press power on-off	PTD UI illuminated when "on", off when "off"
38*	VCC Compressor	Press power on-off	Compressor running when "on"; stopped when "off"
15	Evaporator Fan	Press power on-off	Stopped when "off". Listen for speed change from "LO" to "HI".
22	Damper	Set	With inspection mirror, observe damper open when "OP"; closed when "CL."
36	Ice Chute Door	Depress ice chute door or press power on-off	"OP" on UI when manually opened; "CL" when closed. Or using "power on-off", "OP" on UI when solenoid activated, "CL" when deactivated
29	FF Thermistor	Activates automatically	UI shows temperature sensed by FF thermistor; pass if within 10°F of temperature measured with gauge at FF thermistor location. "OP" if open; "SH" if short
30	FZ Thermistor	Activates automatically	UI shows temperature sensed by FZ thermistor; pass if within 10°F of temperature measured with gauge at FZ thermistor location. "OP" if open; "SH" if short
33	Ambient Thermistor @ Main Board	Activates automatically	UI shows temperature sensed at main board; pass if within +20°F/-10°F of temperature measured with gauge at main board location. "OP" if open; "SH" if short
39	Evaporator Thermistor	Activates automatically	UI shows temperature sensed by evaporator thermistor; pass if within 10°F of temperature measured with gauge at evaporator thermistor location. "OP" if open; "SH" if short
45	Ice Maker Mold Thermistor	Activates automatically	UI shows temperature sensed at ice maker; pass if within +20°F/-10°F of temperature measured with gauge at ice maker mold. "OP" if open; "SH" if short
0-	Firmware Parameters	Press power on-off	Displays digit sequence; record
2-	Main Board Firmware	Press power on-off	Displays digit sequence; record
4-	UI Firmware	Press power on-off	Displays digit sequence; record

IMPORTANT SAFETY NOTE
The information provided herein is designed to assist qualified repair personnel only. Untrained persons should not attempt to make repairs due to the possibility of electrical shock. Disconnect power cord before servicing this appliance.
IMPORTANT
If any green grounding wires are removed during servicing, they must be returned to their original position and properly secured.

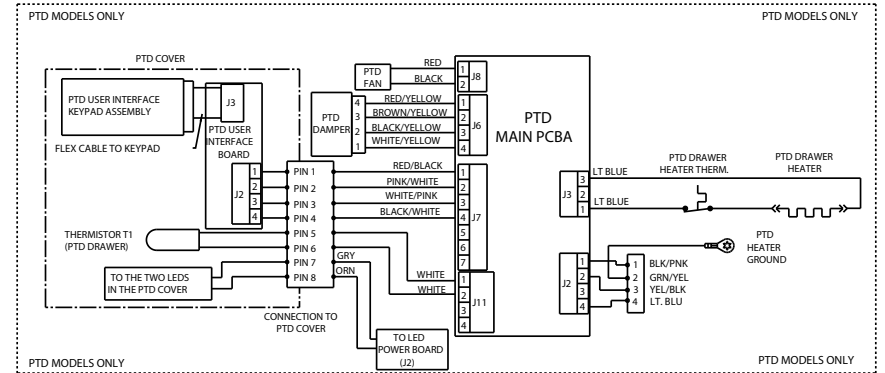

- PTD ERROR CODES:**
- 9X - SHORTED KEY/BUTTON, WHERE THE "X" IS:
1 FOR "ON/OFF"
2 FOR "+"
3 FOR "C/F"
4 FOR "-"
5 FOR "LOCK"
6 FOR "DOWN ARROW KEY"
7 FOR "UP ARROW KEY"
 - 2X - OPEN NTC, WHERE THE "X" IS:
1 FOR THE PTD DRAWER NTC
2 FOR PTD FREEZER AIR NTC
 - 3X - SHORTED NTC, WHERE THE "X" IS:
1 FOR THE PTD DRAWER NTC
2 FOR PTD FREEZER AIR NTC
 - CE - LOSS OF COMMUNICATION BETWEEN UI AND MAIN PCB
 - HI T° - UCL OVER TEMP TIME OUT EXCEEDED
 - LO T° - LCL UNDER TEMP TIME OUT EXCEEDED

ABBR.	EXPLANATION
AT1	9 PIN CONNECTION AT AIR TOWER
IM1	9 PIN CONNECTION IN FRESH FOOD ICEMAKER COMPARTMENT
IM2	6 PIN CONNECTION IN FRESH FOOD ICEMAKER COMPARTMENT
LH1	6 PIN CONNECTION AT THE LEFT DOOR UPPER HINGE
LH2	5 PIN CONNECTION AT THE LEFT DOOR UPPER HINGE
MB1	9 PIN CONNECTION IN THE MAIN BOARD HOUSING BEHIND THE TOE GRILLE
MB2	4 PIN CONNECTION IN THE MAIN BOARD HOUSING BEHIND THE TOE GRILLE
MC1	9 PIN CONNECTION IN THE MACHINE COMPARTMENT TO THE LEFT OF THE COMPRESSOR
MC2	8 PIN CONNECTION IN THE MACHINE COMPARTMENT TO THE LEFT OF THE COMPRESSOR
RH1	9 PIN CONNECTION AT THE RIGHT DOOR UPPER HINGE
RH2	5 PIN CONNECTION AT THE RIGHT DOOR UPPER HINGE
RH3	2 PIN CONNECTION WITH THICKER WIRES AT THE RIGHT DOOR UPPER HINGE
RH4	2 PIN CONNECTION WITH SMALLER WIRES AT THE RIGHT DOOR UPPER HINGE

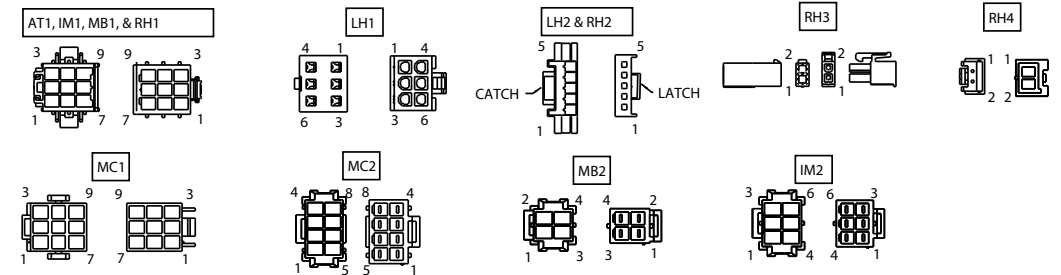
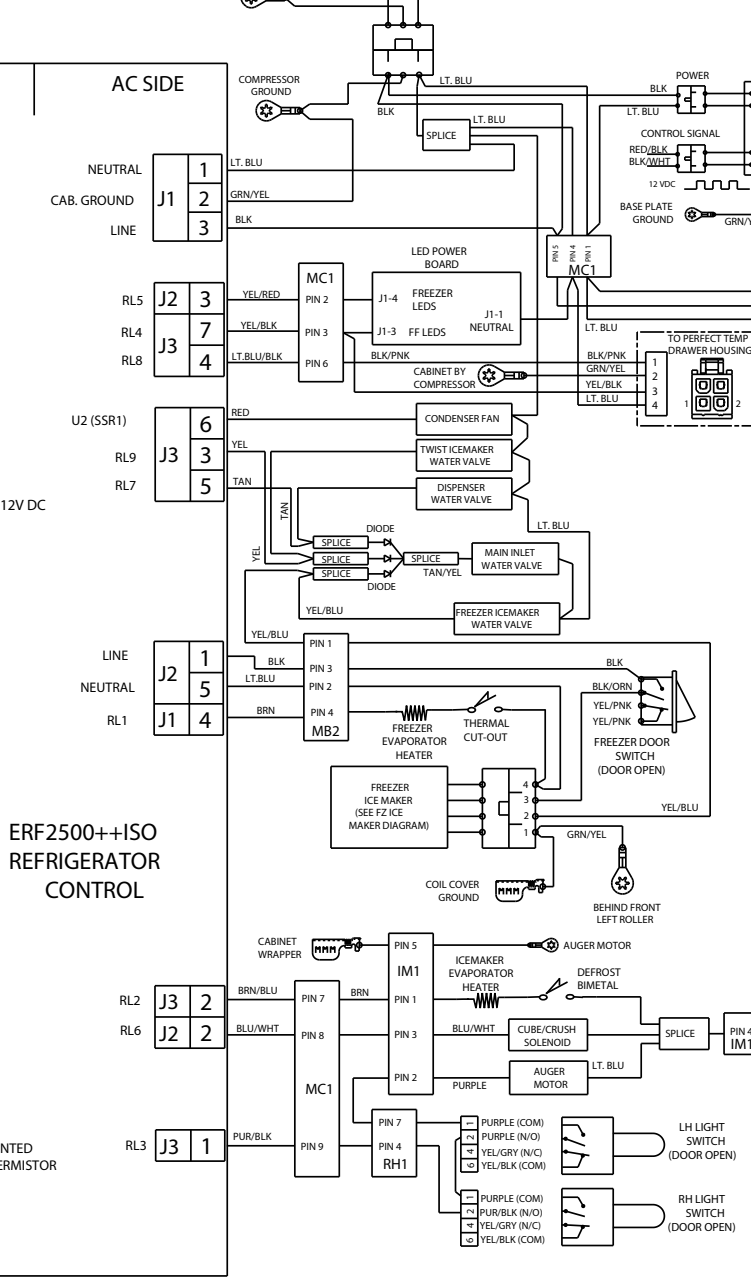
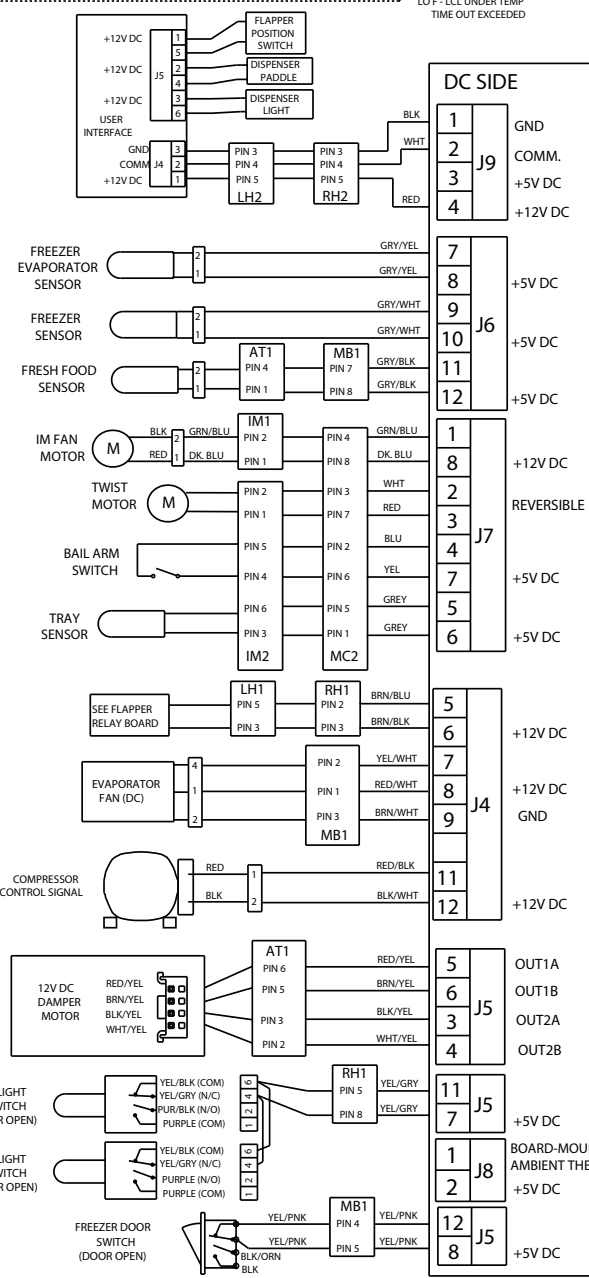
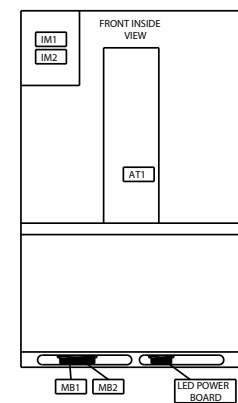
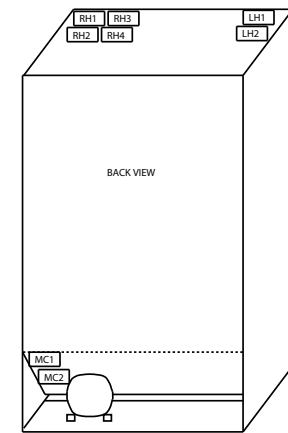

BOARD VIEW

