

Use And Care

G U I D E

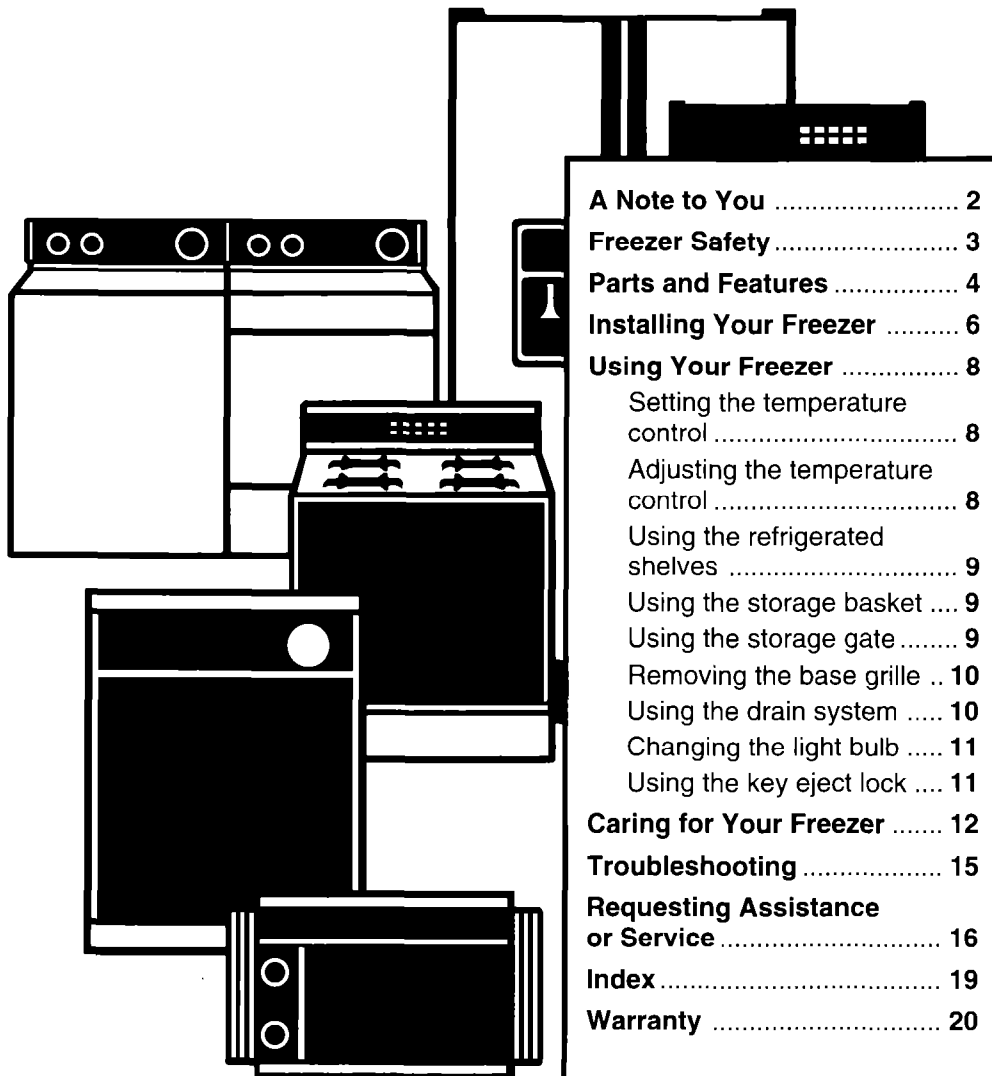

A Note to You	2
Freezer Safety	3
Parts and Features	4
Installing Your Freezer	6
Using Your Freezer	8
Setting the temperature control	8
Adjusting the temperature control	8
Using the refrigerated shelves	9
Using the storage basket	9
Using the storage gate	9
Removing the base grille ..	10
Using the drain system	10
Changing the light bulb	11
Using the key eject lock	11
Caring for Your Freezer	12
Troubleshooting	15
Requesting Assistance or Service	16
Index	19
Warranty	20

1-800-44-ROPER

Call us with questions or comments.

UPRIGHT FREEZERS

7/95

A Note to You

Thank you for buying a Roper® appliance.

Roper appliances give you all the functionality of name brand appliances at a value price. To ensure you enjoy years of trouble-free operation, we developed this Use and Care Guide. It contains valuable information about how to operate and maintain your appliance properly and safely. Please read it carefully. Also, please complete and mail the Ownership Registration Card provided with your appliance. This card helps us notify you about any new information on your appliance.

Please record your model's information.

Whenever you call to request service for your appliance, you need to know your complete model number and serial number. You can find this information on the model and serial number label (see diagrams on pages 4-5 for location of label).

Please also record the purchase date of your appliance and your dealer's name, address, and telephone number.

Model Number _____

Serial Number _____

Purchase Date _____

Dealer Name _____

Dealer Phone _____

Keep this book and the sales slip together in a safe place for future reference.

**Our toll-free number is
available 24 hours a day.**

1-800-447-6737

Freezer Safety

Your safety is important to us.

This guide contains safety statements under warning symbols. Please pay special attention to these symbols and follow any instructions given. Here is a brief explanation of the use of the warning symbol.

WARNING

This symbol alerts you to such dangers as personal injury, burns, fire, and electrical shock.

IMPORTANT SAFETY INSTRUCTIONS

WARNING

To reduce the risk of fire, electrical shock, or injury when using your freezer, follow these basic precautions:

- Read all operating instructions before using your freezer.
- Child entrapment and suffocations are not problems of the past. Junked or abandoned freezers are still dangerous, even if they will “just sit in the garage for a few days.”

If you are getting rid of your old freezer, do it safely. Please read the enclosed safety booklet from the Association of Home Appliance Manufacturers. Help prevent accidents.

- Never allow children to operate, play with, or crawl inside the freezer.
- Never clean freezer parts with flammable fluids. The fumes can create a fire hazard or explosion.

• FOR YOUR SAFETY •

DO NOT STORE OR USE GASOLINE OR OTHER FLAMMABLE VAPORS AND LIQUIDS IN THE VICINITY OF THIS OR ANY OTHER APPLIANCE. THE FUMES CAN CREATE A FIRE HAZARD OR EXPLOSION.

– SAVE THESE INSTRUCTIONS –

Help us help you

Please:

- Install and level the freezer on a floor that will hold the weight and in an area suitable for its size and use.
- Do not install the freezer near an oven, radiator, or other heat source.
- Use the freezer only in an area where the temperature will not exceed 110°F (43.3°C) or drop below 55°F (13°C).
- Keep the freezer out of the weather.
- Connect the freezer only to the proper kind of outlet, with the correct electrical supply and grounding. (See “Locating the proper electrical supply” on page 6.)
- Do not load the freezer with food before it has time to get properly cold.
- Use the freezer only to do what home freezers are designed to do.
- Properly maintain the freezer.
- Make sure the freezer is not used by anyone unable to operate it properly.

Also, if your freezer has a Consumer Buy Guide Label, remove it, any packaging materials, tape, and inside labels (except the model and serial number label) before using the freezer.

To remove any remaining glue:

- Rub briskly with thumb to make a ball, then remove.

OR

- Soak area with liquid hand dishwashing detergent before removing glue as described above.

Do not use sharp instruments, rubbing alcohol, flammable fluids, or abrasive cleaners. These can damage the material. See “Important Safety Instructions” above.

NOTE: Do not remove the Tech Sheet located on the back of the freezer.

Parts and Features

This section contains captioned illustrations of your appliance. Use them to become familiar with where all parts and features are located and what they look like. Page references are included for your convenience.

NOTE: The model you have purchased may have all or some of the parts and features shown and they may not match the illustration exactly. This manual covers several models.

Style 1

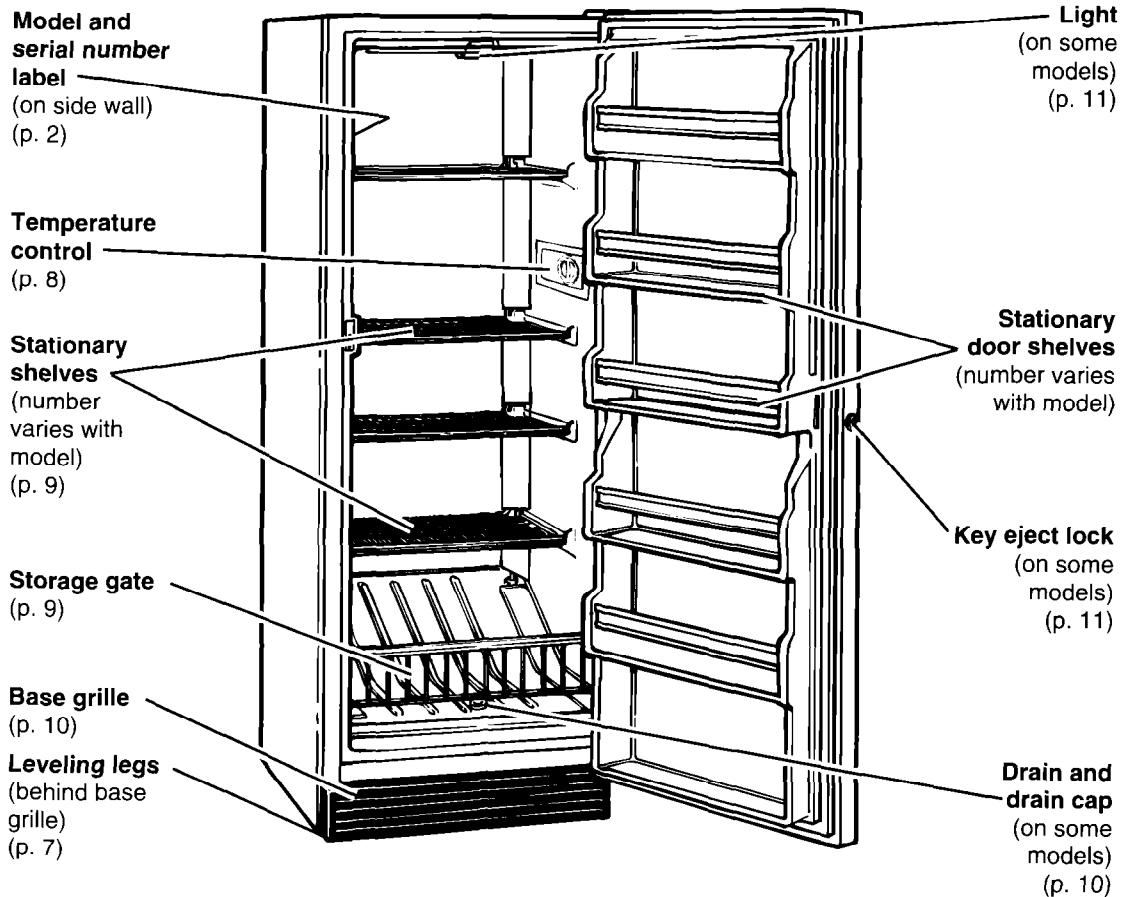

Style 2

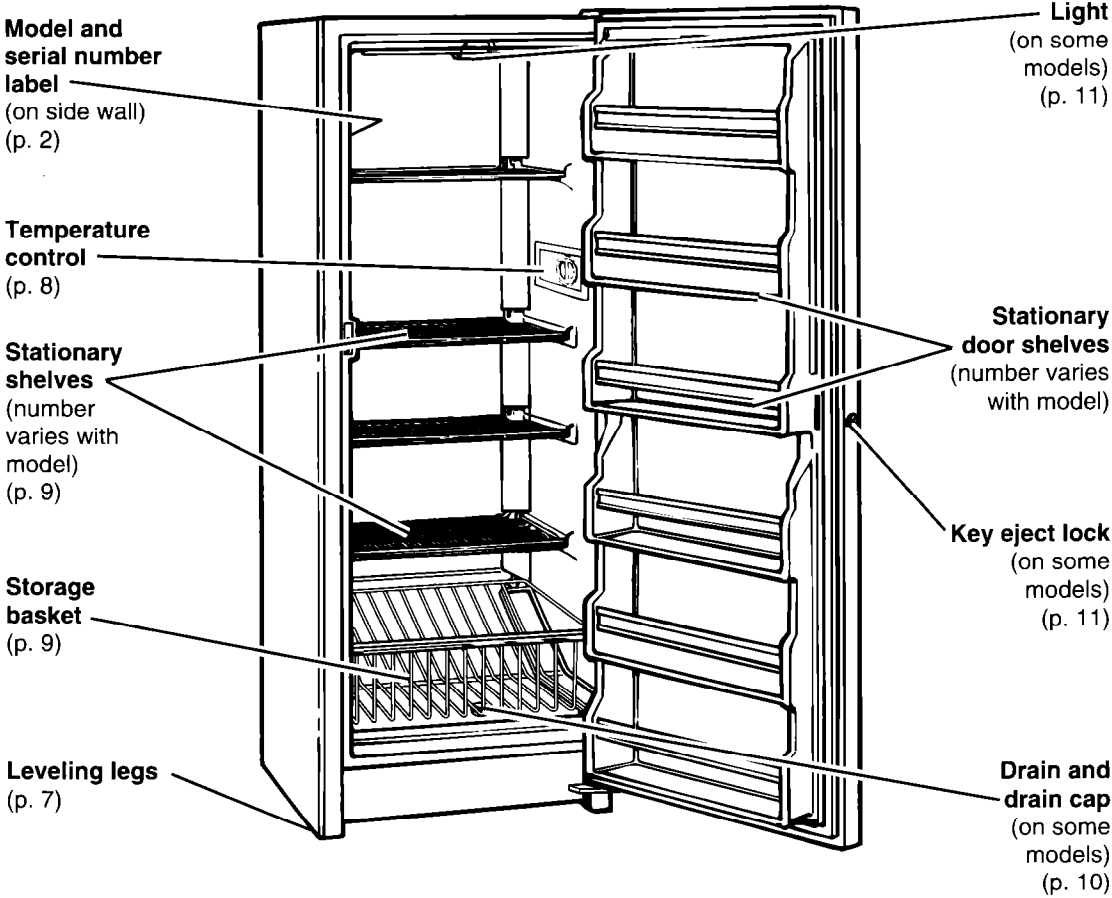

Installing Your Freezer

Proper installation of any appliance is very important. This section will tell you everything you need to know to install your freezer properly.

Installing the handle

1. Remove screws from front of freezer door and discard.
2. Locate handle assembly kit among packing materials.
3. Attach top of handle to top hole in door with shorter of 2 screws provided.
4. Attach bottom of handle to lower hole in door with longer of 2 screws.
5. Snap trim piece into place.

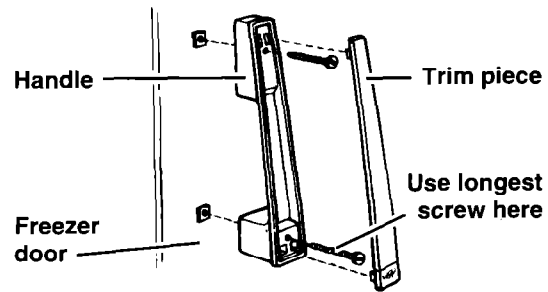

Cleaning your freezer

Clean your freezer thoroughly before using it.

1. Use a sponge, cloth, or paper towel and mild detergent in warm water to clean outside and inside of freezer, door liner, and gasket.
2. Rinse and dry thoroughly.

Locating the proper electrical supply

Recommended Grounding Method

A 115 Volt, 60 Hz., AC only 15 or 20 ampere fused and properly grounded electrical supply is required. It is recommended that a separate circuit serving only this appliance be provided. Use a receptacle which cannot be turned off with a switch or pull chain. Do not use an extension cord.

Attach power cord lock, from literature package inside the freezer, over power cord plug. See Electrical Requirements and Grounding Instructions Sheet in literature package for complete details.

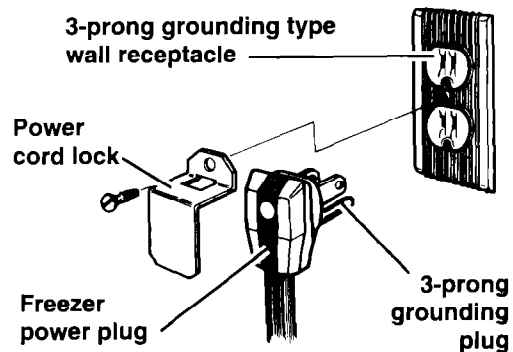

Choosing the proper location

Read the following items before choosing the location for the freezer. See “Completing the installation” below **before** sliding freezer into place.

1. Pick a safe place, indoors, away from flammables such as gasoline.
2. Check the strength of the floor. It should hold the weight of a fully loaded freezer.
3. Allow at least 3 inches (7.5 cm) of air space at top and both sides of freezer.
4. Allow at least 1 inch (2.5 cm) of air space between the back of the freezer and the wall.
5. If the freezer is to be against a wall, you might want to leave extra space on the hinge side so the door can be opened wider.

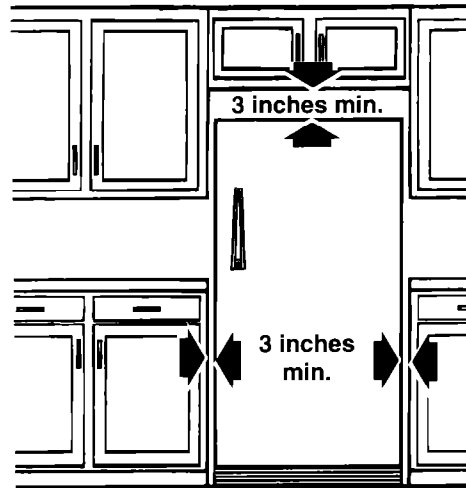

Completing the installation

Level freezer so the door will stay open at any position.

1. Locate, remove, and discard the 4 bolts that held the freezer in the shipping crate.
2. Locate the 2 front leveling legs taped among the packing materials.
3. Screw these legs into the front holes on the bottom of the freezer. The back of the freezer rests on 2 fixed supports.
4. Adjust the 2 front legs so freezer does not rock.
5. Connect freezer to proper electrical supply and attach power cord lock. (Refer to “Locating the proper electrical supply” on page 6.)
6. Slide freezer into place.
7. Place a level on top of the freezer – first side to side then front to back. Turn leg counterclockwise to raise a corner. Turn leg clockwise to lower a corner.
8. Repeat Step 7 until the freezer is level.
9. After freezer is fully loaded, re-check with level.

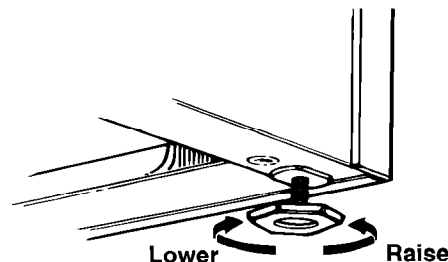

Using Your Freezer

In order to obtain the best possible results from your freezer, you must operate it properly. This section will tell you how to do just that.

Setting the temperature control

Turn the control to 4. This setting is designed to maintain the temperature at or near 0°F (-17.8°C) under normal operating conditions.

Allow the freezer to cool 6 to 8 hours before filling with frozen food. Let the freezer cool overnight before adding large amounts of unfrozen food. Never add more than 2-3 pounds of unfrozen food per cubic foot of freezer space.

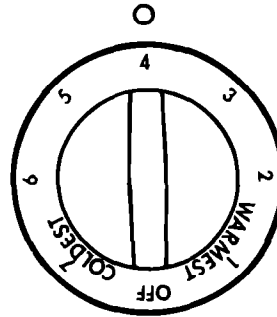

NOTE: When the freezer is first started, the compressor will run constantly until the cabinet is cooled. It may take up to 6 to 8 hours or longer, depending on room temperature and the number of times the freezer door is opened.

After the cabinet is cooled, the compressor will turn on and off as needed to keep the freezer at the proper temperature.

The outside of your freezer may feel warm. This is normal. The freezer's design and main function is to remove heat from packages and air space inside the freezer. This heat is transferred to the room air, so the outside of the freezer may feel warm.

Adjusting the temperature control

- Turn control to a higher number for colder temperatures.
- Turn control to a lower number for less cold temperatures.

Using the refrigerated shelves (on some models)

Your freezer is equipped with refrigerated interior shelves. Packages in direct contact with the shelves will have the best refrigeration. Fresh, unfrozen food packages should be stored directly on the shelves and not on top of already frozen food packages.

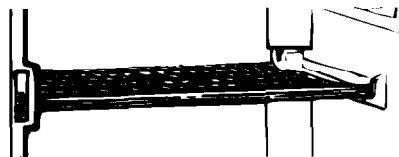

When placing the food packages in your freezer, please remember:

- The cabinet shelves have the best freezing capability. The door shelves and the bottom of the cabinet have a slightly higher temperature. Therefore, packages sensitive to temperature (meat, poultry, etc.) should not be placed on the door shelves or the freezer bottom.
- Give the cold air a chance to completely surround the packages.

Using the storage basket (on some models)

To remove storage basket:

- Lift basket out from freezer floor.

To replace storage basket:

- Lower basket onto freezer floor.

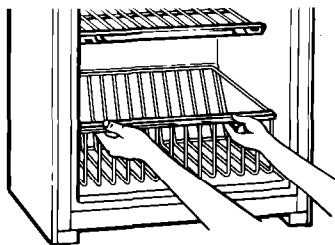

Using the storage gate (on some models)

To lower storage gate:

1. Lift top of gate up slightly to clear supports.
2. Pull gate forward.

To raise storage gate:

1. Return gate to upright position.
2. Lift top of gate slightly to clear supports.
3. Lower gate into supports.

Pull top up,
then forward.

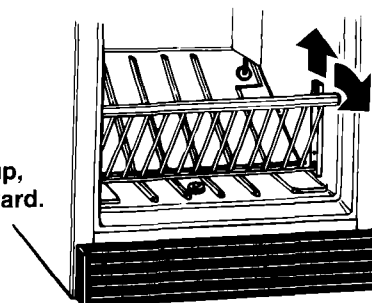

Removing the base grille (on some models)

For manual-defrost models: The base grille will need to be removed when defrosting the freezer.

To remove the grille:

1. Open the door.
2. Pull on both sides of the grille.

To replace the grille:

1. Line up grille support tabs with openings in freezer cabinet.
2. Push firmly to snap grille into place.
3. Close the door.

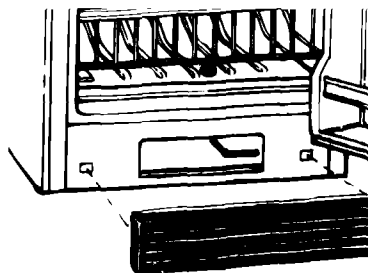

Using the drain system (on some models)

The freezer's drain system consists of:

- drain cap and sleeve (at the liner and cabinet bottom); and
- drain hose.

The drain hose carries defrost water out of the freezer, and through the area behind the base grille, into a drain pan for disposal.

NOTE: The drain cap must be removed before defrosting the freezer and replaced securely afterward.

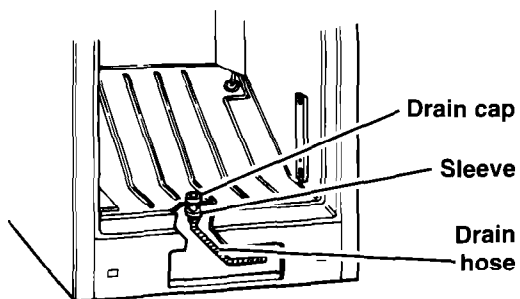

Changing the light bulb (on some models)

⚠ WARNING

Electrical Shock Hazard

Before removing the light bulb, either turn Temperature Control to OFF and unplug the freezer, or disconnect the electricity leading to the freezer at the main power supply.

Shock and injury can occur if electricity remains connected.

To replace interior light:

1. Disconnect freezer from power supply, and turn Temperature Control to OFF.
NOTE: Turning Temperature Control to OFF does not disconnect power to the freezer.
2. Remove the light shield by squeezing sides slightly and pulling out.
3. Replace bulb with 15-watt appliance bulb.
4. Replace light shield. Insert back tabs into slots and squeeze shield slightly to insert front tabs into slots.
5. Reconnect freezer to power supply and refer to "Setting the temperature control" on page 8.

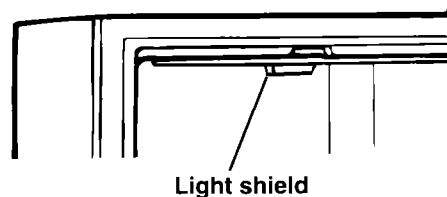

Using the key eject lock (on some models)

If your freezer is equipped with a lock, it can help reduce the hazard of child entrapment.

To lock or unlock the freezer, you must hold the key in the lock while turning. The lock is spring loaded, so the key cannot be left in the lock.

If the key is lost, contact your Roper dealer for a replacement. Always give the complete model and serial number of your freezer when requesting a replacement key.

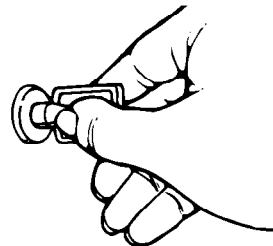

Caring for Your Freezer

Your freezer is designed to give you years of dependable service. However, there are a few things you can do to ensure a long product life. This section will tell you how to care for your freezer properly.

Cleaning manual-defrost models

Defrost and clean your freezer when frost has built up to about ¼ inch (6 mm) thickness. Complete defrosting and cleaning should be done at least once a year. In high humidity areas, your freezer may need more frequent defrosting and cleaning.

1. Unplug power cord, and turn Temperature Control to OFF.
2. Remove all frozen food. Wrap frozen food in several layers of newspaper and cover with a blanket. Food will stay frozen for several hours.

OR

Store frozen food in a cooler, additional refrigerator-freezer, or in a cool area.

3. **For models with a drain system:**
Remove the base grille (see page 10) and reach under the unit to pull the drain hose out through the opening. Place a shallow pan under the drain hose. Remove the drain cap inside the freezer.
NOTE: Check the drain pan frequently to avoid water overflow. Have a second pan handy for easier emptying of drain pan.
For models without a drain system:
Use a large sponge or plastic baster to remove excess water from the freezer bottom. You might want to have a pan close by to wring the sponge or empty the baster into.
4. Place pans of hot water in freezer with door open to speed melting. Directing air from an electric fan into freezer will also help. Do not place fan in freezer.
5. Use a plastic scraper to remove frost.
6. Wipe water from walls with a towel or sponge.

⚠ WARNING

Electrical Shock and Product Damage Hazard

- Turning the Temperature Control to OFF does not remove power to the unit. Failure to unplug the power cord before cleaning or servicing freezer could result in electrical shock.
- Do not place electrical devices in freezer when defrosting. Shock or injury can occur.
- Do not use an ice pick, knife, or other sharp-pointed tool to defrost freezer. Damage can occur.
- Do not use abrasive cleaners on your freezer. Do not use cleaning waxes, concentrated detergents, bleaches, or cleaners containing petroleum on plastic parts. Damage can occur.

7. Wash the inside walls with a solution of 2 tablespoons (26 mg) baking soda to 1 quart (0.95 L) warm water.
8. Rinse and dry thoroughly.
9. Use a sponge, cloth, or paper towel and mild detergent in warm water to clean outside of freezer, door liner, and gasket.
10. Rinse and dry thoroughly.
11. Wax painted metal surfaces outside of freezer to provide rust protection.
NOTE: Do not use wax on plastic parts. Wax may damage them.
12. **For models with a drain system:**
Replace the drain hose, drain cap, and base grille.
13. Replace all frozen food.
14. Plug in power cord and refer to "Setting the temperature control" on page 8.

Cleaning frost-free models

Frost-free means that you will never have to defrost your freezer. Frost is removed by air moving and collecting any moisture and depositing it on the cooling coil. The cooling coil periodically warms up just enough to melt the frost and it then flows down to the drain pan (located behind the base grille) where it is evaporated.

Complete cleaning should be done at least once a year.

1. Unplug power cord, and turn Temperature Control to OFF.
2. Remove all frozen food. Wrap frozen food in several layers of newspaper and cover with a blanket. Food will stay frozen for several hours.

OR

Store frozen food in a cooler, additional refrigerator-freezer, or in a cool area.

3. Wash the inside walls with a solution of 2 tablespoons (26 mg) baking soda to 1 quart (0.95 L) warm water.
4. Rinse and dry thoroughly.

5. Use a sponge, cloth, or paper towel and mild detergent in warm water to clean outside of freezer, door liner, and gasket.
6. Rinse and dry thoroughly.
7. Wax painted metal surfaces outside of freezer to provide rust protection.
NOTE: Do not use wax on plastic parts. Wax may damage them.
8. Replace all frozen food.
9. Plug in power cord and refer to "Setting the temperature control" on page 8.

What to do during power outages

- 1. Call the power company.**
Ask how long power will be off.
- 2. Keep freezer closed if service is to be interrupted 24 hours or less.**
This will help food stay frozen.
- 3. If service is to be interrupted longer than 24 hours, do this:**
Remove all frozen food and store in a frozen food locker.

OR

Place 2 lbs. (0.9 kg) of dry ice in freezer for every cubic foot of freezer space. This will keep foods frozen for 2 to 4 days.

OR

If dry ice or a food locker is not available, use or can perishable food at once.

NOTE: A full freezer stays cold longer than a partly filled one. A freezer full of meat stays cold longer than a freezer full of baked goods.

Food containing ice crystals may be safely refrozen, but the quality and flavor of the food may be affected.

Use refrozen food quickly. If the condition of the food is poor, or you feel it is unsafe to eat, dispose of it immediately.

⚠ WARNING

Personal Injury Hazard

Wear gloves to protect your hands from dry ice burns.

Failure to do so could result in dry ice burns.

Moving care

Remove all frozen food and pack it in dry ice. Unplug the freezer and clean it thoroughly. Tape the door shut and tape electrical cord to the cabinet.

When you get to your new home, refer to pages 6-8 for information on installation and setting controls.

Troubleshooting

Before calling for service, please check the chart below for problems you can fix. It could save you the cost of a service call.

PROBLEM	CHECK THE FOLLOWING
The freezer stops running	<ul style="list-style-type: none">• Is the power cord plugged into a live circuit with the proper voltage?• Is there a blown fuse or tripped circuit breaker?• Has local power failed?• Is the Temperature Control set to a numbered setting?
The motor seems to run too long	<ul style="list-style-type: none">• Is there excessive frost, or a package preventing the door from closing? Defrost and clean freezer, or move package so door closes properly.• Has a large amount of unfrozen food been added to the freezer? The motor will naturally run longer. Add no more unfrozen food at one time than will freeze in 24 hours – approximately 2-3 lbs. per cubic foot of freezer space.• Is the day hot and muggy, or the room too warm? The motor will naturally run longer to provide the correct amount of cooling.• Is there enough air circulation space around the freezer? See “Choosing the proper location” on page 7.

Requesting Assistance or Service

Before calling for assistance or service, please check "Troubleshooting" on page 15. It may save you the cost of a service call. If you still need help, follow the instructions below.

1. If you need assistance* ...

Call our toll-free telephone number. Dial free from anywhere in the U.S.A.:

1-800-44-ROPER
(1-800-447-6737)



and talk with one of our trained consultants. The consultant can instruct you in how to obtain satisfactory operation from your appliance or, if service is necessary, recommend a qualified service company in your area.

If you prefer, write to:

Mr. William Clark
Consumer Assistance Representative
Whirlpool Corporation
2000 North M-63
Benton Harbor, MI 49022-2692

Please include a daytime phone number in your correspondence.

2. If you need service* ...

Contact the dealer from whom you purchased the appliance or the authorized servicer in your area. For help finding an authorized servicer in your area, call our toll-free number in Step 1.



3. If you need FSP® replacement parts ...

FSP is a registered trademark of Whirlpool Corporation for quality parts. Look for this symbol of quality whenever you need a replacement part for your Roper® appliance. FSP replacement parts will fit right and work right, because they are made to the same exacting specifications used to build every new Roper appliance.

To locate FSP replacement parts in your area, refer to Step 2 or call our toll-free telephone number in Step 1.

4. If you are not satisfied with how the problem was solved ...

- Contact the Major Appliance Consumer Action Panel (MACAP). MACAP is a group of independent consumer experts that voices consumer views at the highest levels of the major appliance industry.
- Contact MACAP only when the dealer, authorized servicer, and Whirlpool have failed to resolve your problem.

Major Appliance Consumer Action Panel
20 North Wacker Drive
Chicago, IL 60606

- MACAP will in turn inform us of your action.

*When asking for help or service:

Please provide a detailed description of the problem, your appliance's complete model and serial numbers, and the purchase date. (See page 2.) This information will help us respond properly to your request.

Index

This index is alphabetical. Look for the word or phrase you are interested in, then look for the page number.

<u>TOPIC</u>	<u>PAGE</u>	<u>TOPIC</u>	<u>PAGE</u>
ASSISTANCE		LIGHT BULB	11
Requesting	16	LOCK	11
BASE GRILLE		MOVING CARE	14
Removing	10	PARTS/FEATURES	4-5
BASKET	9	POWER OUTAGES	14
CLEANING		RESPONSIBILITIES	
Before using	6	Owner	3
Frost-free models	13	SAFETY	3
Manual-defrost models	12	SERVICE	
CONTROL	8	Requesting	16
DEFROSTING	10, 12	SHELVES	9
DRAIN SYSTEM	10	TEMPERATURE CONTROL	
ELECTRICAL REQUIREMENTS		Setting	8
Locating proper supply	6	Adjusting	8
FEATURES/PARTS	4-5	TROUBLESHOOTING	15
GATE	9	WARRANTY	20
HANDLE			
Installing	6		
INSTALLING			
Choosing proper location	7		
Handle	6		
Leveling	7		

ROPER®

Domestic Freezer Warranty

LENGTH OF WARRANTY	WE WILL PAY FOR
FULL ONE YEAR WARRANTY (from date of purchase)	Replacement parts and repair labor to correct defects in materials or workmanship.
FULL FIVE YEAR WARRANTY (from date of purchase)	Replacement parts and repair labor to correct defects in materials or workmanship in the sealed refrigeration system. These parts are: 1. Compressor 4. Drier 2. Evaporator 5. Connecting Tubing 3. Condenser
WE WILL NOT PAY FOR	
<p>A. Service calls to:</p> <ol style="list-style-type: none"> 1. Correct the installation of your freezer. 2. Instruct you how to use your freezer. 3. Replace house fuses or correct house wiring or plumbing. 4. Replace light bulbs or batteries. <p>B. Pickup and delivery. Your freezer is designed to be repaired in the home.</p> <p>C. Damage to your freezer caused by accident, misuse, fire, flood, acts of God, or use of products not approved by Whirlpool.</p> <p>D. Food loss coverage for freezers used in commercial applications.</p> <p>E. Repairs to parts or systems caused by unauthorized modifications made to the appliance.</p>	

6-94

Limited domestic food loss coverage. See below for details on limited domestic food loss protection plan. Service under the full warranties must be provided by an authorized Roper service company.

This Roper appliance is warranted by Whirlpool Corporation. Under no circumstances shall it be liable under this warranty for incidental or consequential damages and all implied warranties are limited to the same time period stated in the express warranties for Roper Brand Appliances. Some states do not allow the exclusion or limitation of incidental or consequential damages, or limitation of implied warranties, so this limitation or exclusion may not apply to you.

Outside the United States, a different warranty may apply. For details, please contact your authorized Roper distributor or military exchange.

LIMITED DOMESTIC FOOD LOSS COVERAGE REIMBURSEMENT FOR FOOD LOSSES.

During the first year of ownership, the Roper Freezer warranty provides reimbursement as stated below for food actually spoiled while stored in the freezer as a result of defects in materials or workmanship.

During the second through fifth years of ownership, reimbursement will be made as stated below for food actually spoiled while stored in the freezer as a result of a **FAILURE OF THE SEALED REFRIGERATION SYSTEM.**

Food spoilage losses must be verified by Roper Brand Appliance warrantor or an authorized Roper service company. Reimbursement of losses will be based on domestic use and freezer size up to the total cumulative amount shown for the five year warranty period.

9.9 cubic feet or smaller	up to \$150.00 maximum payment
10.0 to 16.0 cubic feet	up to \$300.00 maximum payment
16.1 cubic feet or larger	up to \$400.00 maximum payment

The reimbursement amounts shown may or may not cover the actual replacement cost of the contents of your freezer. They are, however, the maximum payments that will be paid and they are cumulative for the five year warranty period.

Sorry, but warrantor is not responsible for food losses caused by natural spoilage, misuse, or negligent care of the freezer, or by accidental or intentional disconnecting of the electrical power cord, power interruption, inadequate power, fire damage, water damage, theft, riots, strikes, war, or acts of God.

If you need service, first see the "Requesting Assistance or Service" section of this book. After checking "Requesting Assistance or Service," additional help can be found by calling our toll-free telephone number, **1-800-44-ROPER**, from anywhere in the U.S.A.

PART NO. 1-81120 Rev. 1/2165596