

# 30" GAS RANGE INSTALLATION INSTRUCTIONS

INSTALLATION AND SERVICE MUST BE PERFORMED BY A QUALIFIED INSTALLER.

**IMPORTANT: SAVE FOR LOCAL ELECTRICAL INSPECTOR'S USE.  
READ AND SAVE THESE INSTRUCTIONS FOR FUTURE REFERENCE.**



**⚠ WARNING FOR YOUR SAFETY:** Do not store or use gasoline or other flammable vapors and liquids in the vicinity of this or any other appliance.

**⚠ WARNING** If the information in this manual is not followed exactly, a fire or explosion may result causing property damage, personal injury or death.

**FOR YOUR SAFETY:**

- Do not store or use gasoline or other flammable vapors and liquids in the vicinity of this or any other appliance.
- **WHAT TO DO IF YOU SMELL GAS:**
  - Do not try to light any appliance.
  - Do not touch any electrical switch; do not use any phone in your building.
  - Immediately call your gas supplier from a neighbor's phone. Follow the gas supplier's instructions.
  - If you cannot reach your gas supplier, call the fire department.
- Installation and service must be performed by a qualified installer, service agency or the gas supplier.

## ⚠ WARNING



- All appliances can tip.
- Injury to persons could result.
- Install anti-tip bracket packed with your appliance.
- See Installation Instructions.

Note: For appliance installed in the State of Massachusetts see page 2.

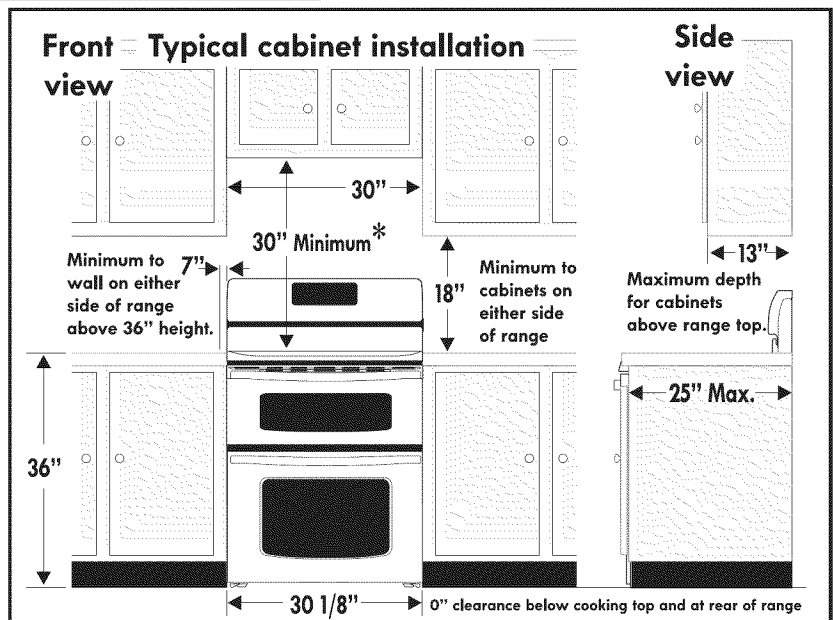
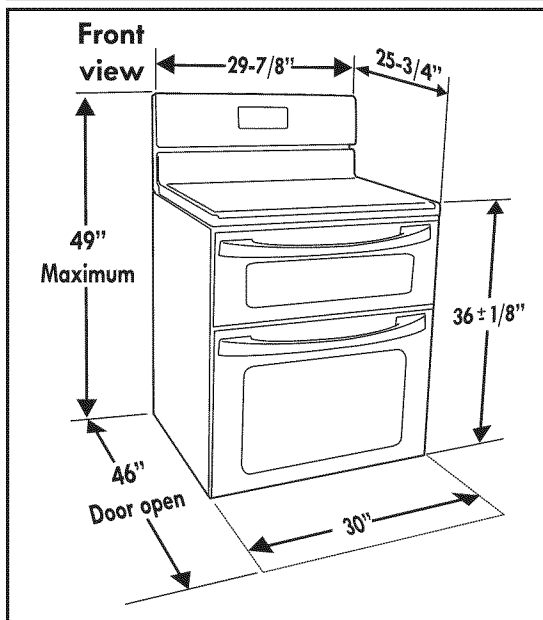

\* 30" minimum clearance between the top of the cooking surface and the bottom of an unprotected wood or metal cabinet; or 24" minimum when bottom of wood or metal cabinet is protected by not less than 1/4" flame retardant millboard covered with not less than no. 28 MSG sheet steel, 0.015" stainless steel, 0.024" aluminum or 0.020" copper. The minimum clearance is 0" for the rear of the range. Follow all dimension requirements provided above to prevent property damage, potential fire hazard, and incorrect countertop and cabinet cuts.

**Avoid locating cabinet storage space above the surface burners to eliminate the possibility of cabinets catching on fire, or personal burns from reaching for the cabinets over the heated units. Avoid locating cabinet storage space above the surface burners. The absence of cabinets will eliminate the chance of cabinets catching on fire, and eliminate the possibility of receiving personal burns from reaching for the cabinets over flaming surface burners. If cabinet storage is to be provided, risk can be reduced by installing a range hood that projects horizontally a minimum of 5" beyond the bottom of the cabinets.**

### Clearances and Dimensions

1. **Location—Check location where the range will be installed.** Check for proper electrical and gas supply, and the stability of floor.

2. **Dimensions that are shown must be used.** Given dimensions provide minimum clearance. Contact surface must be solid and level.

# 30" GAS RANGE INSTALLATION INSTRUCTIONS

## Important Notes to the Installer

1. Read all instructions contained in these installation instructions before installing the appliance.
2. Remove all packing material before connecting the electrical supply to the appliance.
3. Observe all governing codes and ordinances.
4. Be sure to leave these instructions with the consumer.
5. Note: For operation at 2000 ft. elevations above sea level, appliance rating shall be reduced by 4 percent for each additional 1000 ft.

## Important Note to the Consumer

Keep these instructions with your Use and Care Guide for future reference.

## IMPORTANT SAFETY INSTRUCTIONS

Installation of this range must conform with local codes or, in the absence of local codes, with the National Fuel Gas Code ANSI Z223.1/NFPA .54-latest edition.

When installed in a manufactured (mobile) home, installation must conform with the Manufactured Home Construction and Safety Standard, Title 24 CFRR, Part 3280 [formerly the Federal Standard for Mobile Home Construction and Safety, Title 24, HUD (Part 280)] or, when such standard is not applicable, the Standard for Manufactured Home Installations, ANSI/NCSBCS A.225.1, or with local codes.

This range has been design certified by CSA International. As with any appliance using gas and generating heat, there are certain safety precautions you should follow. You will find them in the Use and Care Guide, read it carefully.

- **Be sure your range is installed and grounded properly by a qualified installer or service technician.**
- **This range must be electrically grounded in accordance with local codes or, in their absence, with the National Electrical Code ANSI/NFPA No. 70—latest edition.** See Grounding Instructions in the Electrical Requirements section of these Installation Instructions.
- Before installing the range in an area covered with linoleum or any other synthetic floor covering, make sure the floor covering can withstand heat at least 90°F above room temperature without shrinking, warping or discoloring. Do not install the range over carpeting unless you place an insulating pad or sheet of ¼" (10,16cm) thick plywood between the range and carpeting.
- Make sure the wall coverings around the range can withstand the heat generated by the range.
- Do not obstruct the flow of combustion air at the oven vent nor around the base or beneath the lower front panel of the range. Avoid touching the vent openings or nearby surfaces as they may become hot while the oven is in operation. This range requires fresh air for proper burner combustion.
- Air curtains or other overhead range hoods, which operate by blowing a downward air flow onto a range, shall not be used in conjunction with gas ranges other than when the hood and range have been designed, tested and listed by an independent test laboratory for use in combination with each other.

**⚠ WARNING** Never leave children alone or unattended in the area where an appliance is in use. As children grow, teach them the proper, safe use of all appliances. Never leave the oven door open when the range is unattended.

**⚠ WARNING** Stepping, leaning or sitting on the doors or drawers of this range can result in serious injuries and can also cause damage to the range.

- Do not store items of interest to children in the cabinets above the range. Children could be seriously burned climbing on the range to reach items.
- To eliminate the need to reach over the surface burners, cabinet storage space above the burners should be avoided.
- Adjust surface burner flame size so it does not extend beyond the edge of the cooking utensil. Excessive flame is hazardous.
- Do not use the oven as a storage space. This creates a potentially hazardous situation.
- Never use your range for warming or heating the room. Prolonged use of the range without adequate ventilation can be dangerous.
- Do not store or use gasoline or other flammable vapors and liquids near this or any other appliance. Explosions or fires could result.
- In the event of an electrical power outage, the surface burners can be lit manually. To light a surface burner, hold a lit match to the burner head and slowly turn the Surface Control knob to LITE. Use caution when lighting surface burners manually.
- Reset all controls to the "off" position after using a programmable timing operation.
- Remove broiler pan, food and other utensils before self-cleaning the oven. Wipe up excess spillage. Follow the precleaning instructions in the Use and Care Guide.
- Unlike the standard gas range, THIS COOKTOP IS NOT REMOVABLE. Do not attempt to remove the cooktop.

**Special instructions for appliances installed in the state of Massachusetts:** *This Appliance can only be installed in the state of Massachusetts by a Massachusetts licensed plumber or gas fitter. When using a flexible connector, it must not exceed three (3) feet (36 in.) long. A "T" handle type manual gas valve must be installed in the gas supply line to this appliance.*

**⚠ WARNING DO NOT MAKE ANY ATTEMPT TO OPERATE THE ELECTRIC IGNITION OVEN DURING AN ELECTRICAL POWER FAILURE. RESET ALL OVEN CONTROLS TO OFF IN THE EVENT OF A POWER FAILURE.** The electric ignitor will automatically re-ignite the oven burner when power resumes if the oven thermostat control was left in the ON position.

When an electrical power failure occurs during use, the surface burners will continue to operate. During a power outage, the surface burners can be lit with a match. Hold a lighted match to the burner, then slowly turn the knob to the Lite position. Use extreme caution when lighting burners this way.

# 30" GAS RANGE INSTALLATION INSTRUCTIONS

## Before Starting

### Tools you will need

#### For leveling legs and anti-tip brackets:

- Adjustable wrench or channel lock pliers
- 5/16" Nutdriver or Flat Head Screw Driver
- Electric Drill & 1/8 Diameter Drill Bit (5/32" Masonry Drill Bit if installing in concrete)
- Level & Measuring Tape

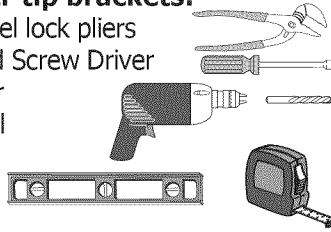

#### For gas supply connection:

- Pipe Wrench
- Brush

#### For burner flame adjustment:

- Phillips head and blade-type screwdrivers

#### For gas conversion (LP/Propane or Natural):

- Open end wrench - 1/2"

#### Additional materials you will need:

- Gas line shut-off valve
- Pipe joint sealant that resists action of LP/Propane gas
- A new flexible metal appliance conduit (1/2" NPT x 3/4" or 1/2" I.D.) must be design certified by CSA International. Because solid pipe restricts moving the range we recommend using a new flexible conduit (4 feet length) for each new installation and additional reinstallations.
- Always use the (2) new flare union adapters 1/2" NPT x 3/4" or 1/2" I.D.) supplied with the new flexible appliance conduit for connection of the range.

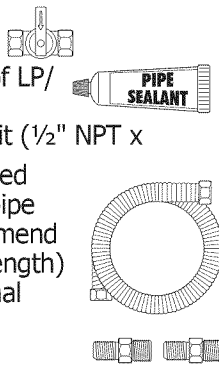

**A. Locate the Bracket Using the Template** - Locate the bracket position (right or left side) by placing the template symmetrically to the center of the final range position. Mark the location of the screw holes, shown on template.

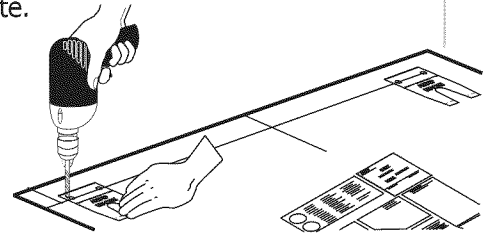
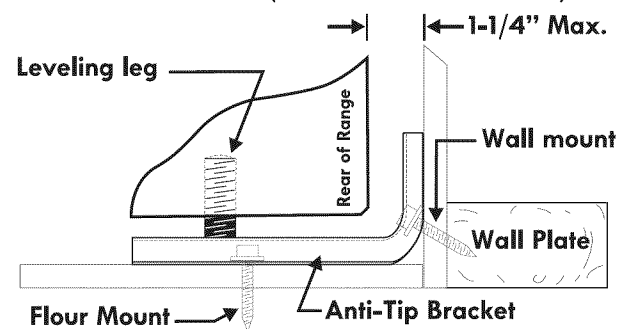

Figure 1

**B. Drill Pilot Holes and Fasten Bracket** - Drill a 1/8" pilot hole where screws are to be located. If bracket is to be mounted to the wall, drill pilot hole at an approximate 20° downward angle. If bracket is to be mounted to masonry or ceramic floors, drill a 3/16" pilot hole 1-3/4" deep. The screws provided may be used in wood or concrete material. Use a 5/16" nut-driver or flat head screwdriver to secure the bracket in place.

#### FASTEN BRACKET (WALL OR FLOOR MOUNTING)



#### FASTEN BRACKET (FLOOR MOUNTING ONLY)

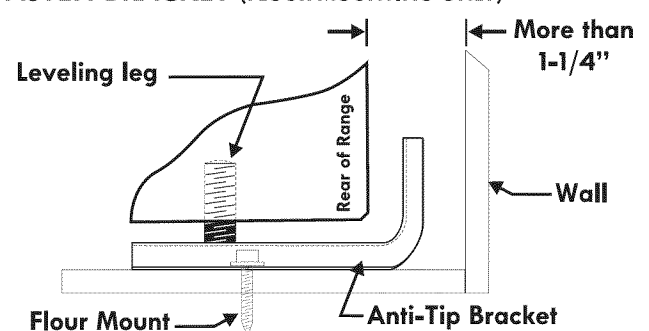

Figure 2

## Normal Installation Steps

### 1 Anti-tip Bracket Installation

#### Instructions Important Safety Warning

To reduce the risk of tipping of the range, the range must be secured to the floor by the properly installed anti-tip bracket and screws packed with the range. Failure to install the anti-tip bracket will allow the range to tip over if excessive weight is placed on an open door or if child climbs upon it. Serious injury might result from spilled hot liquids or from the range itself.

If range is ever moved to a different location, the anti-tip brackets must also be moved and installed with the range.

Instructions are provided for installation in wood or cement floor. When fastening to floor, be sure that screws do not penetrate electrical wiring or plumbing.

# 30" GAS RANGE INSTALLATION INSTRUCTIONS

**C. Level and position the range** - Slide range to its final position. Insert the range leveling leg in the anti-tip bracket. Visually verify if the anti-tip bracket is engaged. Lower the range by adjusting the 4 leveling legs alternatively until the range is level. Check if the range is level by placing a spirit level on the oven rack. Take 2 readings with the spirit level placed diagonally; take a reading in one direction and then in the other direction. Level the range if necessary by adjusting the leveling legs.

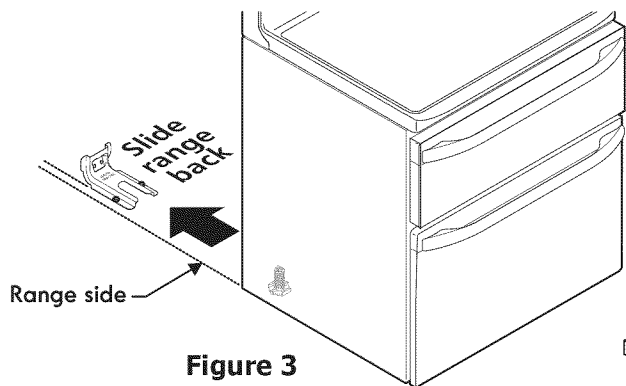

Figure 3

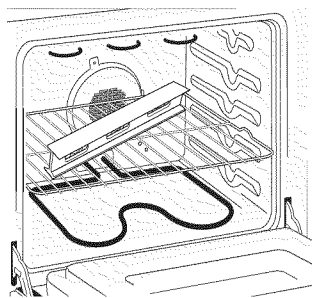

Figure 4

## 2 Provide an adequate Gas Supply

When shipped from the factory, this unit is designed to operate on 4" (10,16cm) water column (1.0 kPa) Natural gas manifold pressure. A convertible pressure regulator is connected to the range manifold and **MUST** be connected in series with the gas supply line. If LP/Propane conversion kit has been used, follow instructions provided with the kit for converting the pressure regulator to LP/Propane use.

Care must be taken during installation of range not to obstruct the flow of combustion and ventilation air.

For proper operation, the maximum inlet pressure to the regulator should be no more than 14" (35,56cm) of water column pressure (3.5 kPa). The inlet pressure to the regulator must be at least 1" (.25 kPa) greater than the regulator manifold pressure setting. Examples: If regulator is set for natural gas 4" (10,16cm) manifold pressure, inlet pressure must be at least 5" (12,60cm); if regulator has been converted for LP/Propane gas 10" (25,4cm) manifold pressure, inlet pressure must be at least 11" (27,9cm).

Leak testing of the appliance shall be conducted according to the instructions in step 4H.

The gas supply line should be 1/2" or 3/4" I.D.

### NOTE:

The electric outlet can be placed anywhere in the hatched area.

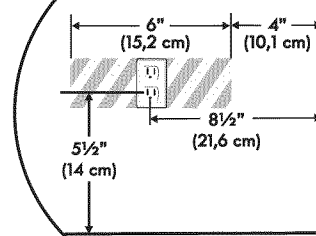

Recommended hole location for through the wall gas entry line.

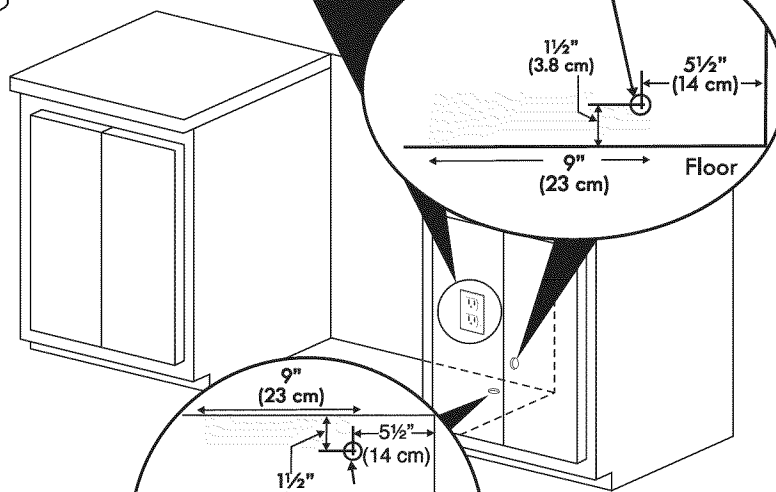

Recommended hole location for through the floor gas entry line.

Figure 5a

**NOTE:** The gas entry line hole can be also placed anywhere in the shaded area.

## 3 Seal the openings

Seal any openings in the floor under the range after gas supply line is installed.

# 30" GAS RANGE INSTALLATION INSTRUCTIONS

## 4 Connect the range to the gas supply

**Important:** Remove all packing material and literature from range before connecting gas and electrical supply.

**Note:** To prevent leaks, put pipe joint sealant on all external pipe threads.

**⚠ CAUTION** Do not allow regulator to rotate on pipe when tightening fittings.

### Connection to Pressure Regulator

The regulator is already installed on the appliance.

**⚠ WARNING** Do not make the connection too tight. The regulator is die cast. Overtightening may crack the regulator resulting in a gas leak and possible fire or explosion.

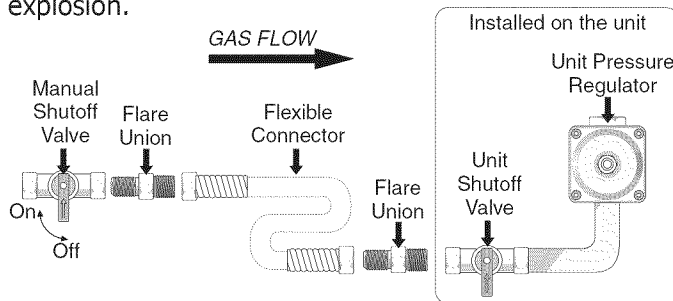

Figure 5b

- Install an external manual gas shut-off valve to gas supply line in an accessible location outside of the range. Be sure you know where and how to shut off the gas supply to the range.
- Install  $\frac{1}{2}$ " flare union adapter to unit shut-off valve using **NO MORE THAN 15ft./lbs.** of torque. **NOTE:** Be sure to stabilize the right side of the unit shut-off valve with adjustable wrench before tightening ANY fittings to the unit shut-off valve.
- Tighten the gas flexible connector and/or appliance conduit to flare union on the left side of the unit shut-off valve using **NO MORE THAN 15ft./lbs.** of torque. Be sure to stabilize the  $\frac{1}{2}$ " flare union adapter with an adjustable wrench before tightening the gas flexible connector and/or appliance conduit.
- Install flare union adapter to external shut-off valve.
- Attach the gas flexible connector with the flare union on shut-off valve.
- Make sure both shut-off valves are in the "ON" position.
- Form the gas flexible connector as shown on figure 5c. This will prevent the flexible connector from pinching or blocking the unit when you will push it back in its final position.
- Check for leaks. Turn the gas supply on to the range and use a liquid leak detector (or soap and water) at all joints and conduits to check for leaks in the system.

**⚠ WARNING** Do not use a flame to check for gas leaks.

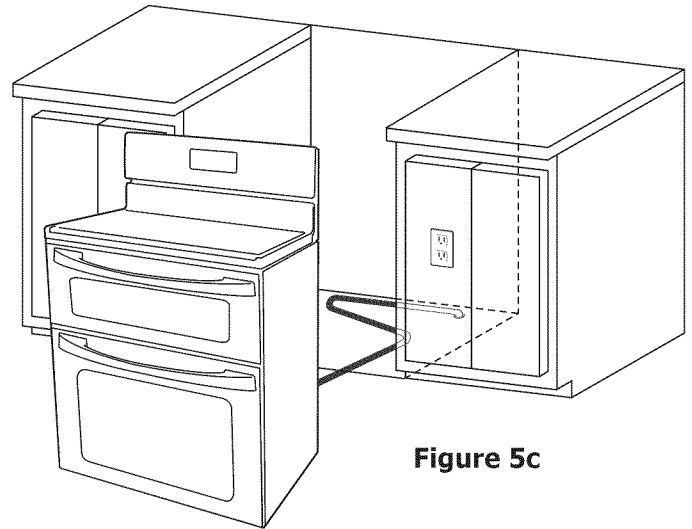

Figure 5c

**Note:** The purpose of forming the gas flexible connector is to position it in a way that will not block the unit or get pinched in its final position.

**If your unit in place is not against the wall as you wish, check behind the range and place the gas flexible connector to avoid the range being blocked or the gas flexible connector being pinched.**

### Checking Manifold Gas Pressure

Disconnect this range and its individual manual shutoff valve from the gas supply piping system during any pressure testing of that system at test pressures greater than 14" water column pressure (approximately  $\frac{1}{2}$ " psig).

The appliance must be isolated from the gas supply piping system by closing its individual manual shutoff valve during any pressure testing of the gas supply piping system at test pressures equal to or less than 14" water column pressure (approximately  $\frac{1}{2}$ " psig).

If it should be necessary to check the manifold gas pressure, connect manometer (water gauge) or other pressure device to the top burner right rear orifice. Using a rubber hose with inside diameter of approximately  $\frac{1}{4}$ " hold tubing down tight over orifice. Turn burner valve on.

For accurate pressure check have at least two (2) other top burners burning. Be sure the gas supply (inlet) pressure is at least one inch above specified range manifold pressure. The gas supply pressure should never be over 14" water column. When properly adjusted for Natural Gas manifold pressure is 4" (For LP/Propane Gas the manifold pressure is 10")

# 30" GAS RANGE INSTALLATION INSTRUCTIONS

## 5 Electrical Requirements

120 volt, 60 Hertz, properly grounded dedicated circuit protected by a 15 amp circuit breaker or time delay fuse.

**Note:** Not recommended to be installed with a Ground Fault Interrupt (GFI).

**Do not use an extension cord with this range.**

### Grounding Instructions

**IMPORTANT Please read carefully.**

**For personal safety, this appliance must be properly grounded.**

The power cord of this appliance is equipped with a 3-prong (grounding) plug which mates with a standard 3-prong grounding wall receptacle (see Figure 6) to minimize the possibility of electric shock hazard from the appliance.

The wall receptacle and circuit should be checked by a qualified electrician to make sure the receptacle is properly grounded.

**Preferred Method**  
**Grounding type**  
**wall receptacle**

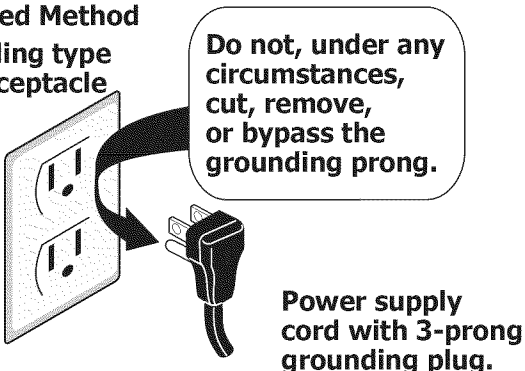

**Figure 6**

Where a standard 2-prong wall receptacle is installed, it is the personal responsibility and obligation of the consumer to have it replaced by a properly grounded 3-prong wall receptacle.

**Do not, under any circumstances, cut or remove the third (ground) prong from the power cord.**

**⚠ WARNING** Disconnect electrical supply cord from wall receptacle before servicing cooktop.

## 6 Assembly of the Burner Caps and Burner Grates

It is very important to make sure that all of the surface burner caps and surface burner grates are installed correctly and in the correct locations.

**Burner Cap**

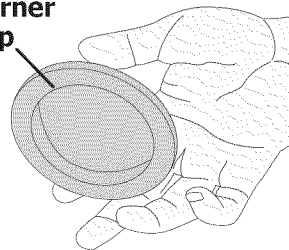

**Please note: The burner heads are secured to the cooktop. THE COOKTOP IS NOT REMOVABLE.** Do not attempt to remove or lift the cooktop.

**Fixed Burner Head**

**Gas Opening**

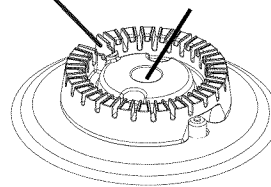

**REMEMBER - DO NOT ALLOW SPILLS' FOOD' CLEANING AGENTS OR ANY OTHER MATERIAL TO ENTER THE GAS OPENING OF THE BURNER.** Always keep the Burner Caps in place whenever the surface burners are in use.

## 7 Electric Ignition Surface Burners

Operation of electric igniters should be checked after range and supply line connectors have been carefully checked for leaks, and range has been connected to electric power. To check for proper lighting:

- A.** Push in and turn a surface burner knob to the LITE position. You will hear the igniter sparking.
- B.** The surface burner should light when gas is available to the top burner. Each burner should light within four (4) seconds after air has been purged from supply lines. Visually check that burner has lit.
- C.** Once the burner lights, the control knob should be rotated out of the LITE position.
- D.** There are separate ignition devices for each burner. Try each knob separately until all burner valves have been checked.

# 30" GAS RANGE INSTALLATION INSTRUCTIONS

## 8 Adjust the "LOW" Setting of Surface Burner Valves

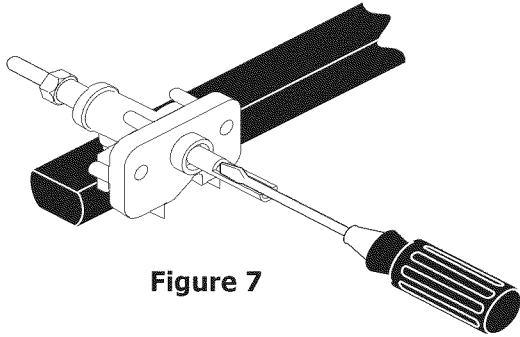
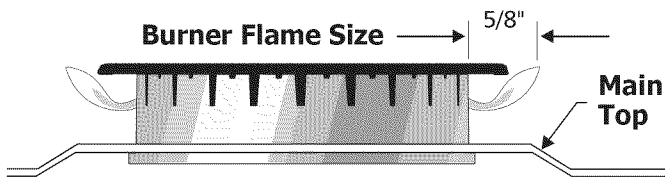

Figure 7

- A. Push in and turn each control to LITE until burner ignites.
- B. Push in and quickly turn knob to LOWEST POSITION.
- C. If burner goes out, Reset control to OFF.
- D. Remove the surface burner control knob.
- E. Insert a thin-bladed screwdriver into the hollow valve stem and engage the slotted screw inside. Flame size can be increased or decreased with the turn of the screw. Turn counterclockwise to increase flame size. Turn clockwise to decrease flame size.



Adjust flame until you can quickly turn knob from LITE to LOWEST POSITION without extinguishing the flame. Flame should be as small as possible without going out.

**Note:** Air mixture adjustment is not required on surface burners.

## 9 Operation of Oven Burners and Oven Adjustments

### Electric Ignition Burners

Operation of electric igniters should be checked after range and supply line connectors have been carefully checked for leaks, and range has been connected to electric power.

The oven burner is equipped with an electric control system as well as electric oven and broil burner igniters. These control systems require no adjustment. When the oven is set to operate, current will flow to the igniter. It will "glow" similar to a light bulb. When the igniter has reached a temperature sufficient to ignite gas, the electrically controlled oven valve will open and flame will appear at the oven burner. There is a time lapse from 30 to 60 seconds after thermostat is turned ON before the flame appears at the oven burner. When the oven reaches the display setting, the glowing igniter will go off. The burner flame will go "out" in 20 to 30 seconds after igniter goes "OFF". To maintain any given oven temperature, this cycle will continue as long as the display is set to operate. After removing all packing materials and literature from the oven:

- A. Set the lower oven to BAKE at 300°F. See Use & Care Guide for operating instructions.
- B. Within 60 seconds the oven burner should ignite. Check for proper flame, and allow the burners to cycle once. Reset controls to OFF.
- C. Repeat A and B with the upper oven.
- D. Set the upper oven to broil. See Use and Care Guide for operating instructions.
- E. Within 60 seconds the broil burner should ignite. Check for proper flame. Reset controls to off.



# 30" GAS RANGE INSTALLATION INSTRUCTIONS

## 10 Air Shutter-Broil Burner

The approximate flame length from the burner is 1 inch (distinct inner cone of blue flame).

To determine if the broil burner flame is proper, set the oven to broil.

If flame is yellow in color, increase air shutter opening size (see "2" in Figure 8 ). If the entire flame is blue, reduce the air shutter opening size.

To adjust, loosen lock screw (see "3" in Figure 8), reposition air shutter, and tighten lock screw.

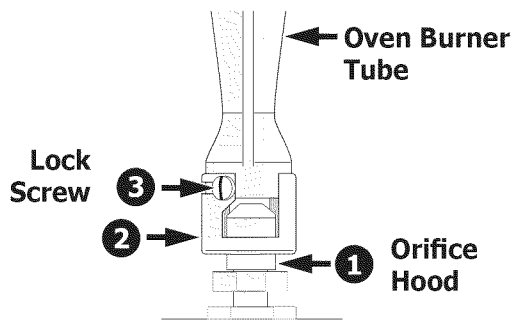

Figure 8

## 11 Make sure range is level

Level the range by placing a level horizontally on an oven rack. Check diagonally from front to back, then level the range by adjusting the leveling legs.

## 12 After installation is completed, make sure all controls are left in the OFF position.

## LP/Propane Gas Conversion

This appliance can be used with Natural gas or LP/Propane gas. It is shipped from the factory for use with natural gas.

If you wish to convert your range for use with LP/Propane gas, use the supplied fixed orifices located in a bag containing the literature marked "FOR LP/PROPANE GAS CONVERSION." Follow the instructions packaged with the orifices for surface, oven and broil burners conversion.

The conversion must be performed by a qualified service technician in accordance with the manufacturer's instructions and all local codes and requirements. Failure to follow these instructions could result in serious injury or property damage. The qualified agency performing this work assumes responsibility for the conversion.

**⚠ WARNING** Failure to make the appropriate conversion can result in serious personal injury and property damage.

## Care, Cleaning and Maintenance

Refer to the Use & Care Guide for cleaning instructions.

If moving the range is necessary for cleaning or maintenance, shut off gas supply. Disconnect the gas and electrical supply. If gas or electrical supply is inaccessible, lift the unit slightly at the front and pull out away from the wall.

Pull only as far as necessary to disconnect the gas and electrical supply. Finish moving the unit for servicing and cleaning. Reinstall in reverse order making sure to level the range and check gas connections for leaks.

## Before You Call for Service

Read the Before You Call for Service Checklist and operating instructions in your **Use and Care Guide**. It may save you time and expense. The list includes common occurrences that are not the result of defective workmanship or materials in this appliance.

## Serial Plate Information

The serial plate is located on the decorative bottom trim and it is visible when the lower oven door is opened.

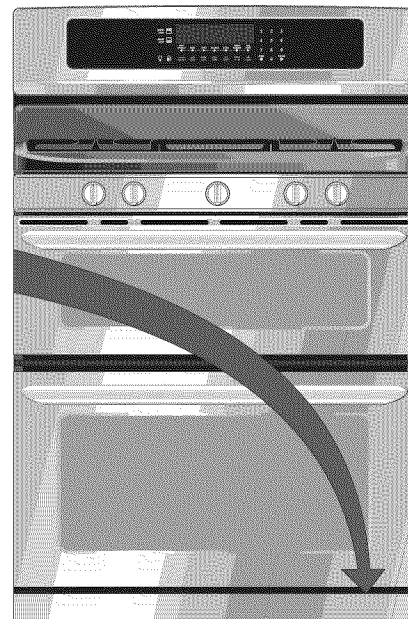



# 30" GAS RANGE INSTALLATION INSTRUCTIONS

Notes

# 30" GAS RANGE INSTALLATION INSTRUCTIONS

## Notes

# 30" GAS RANGE INSTALLATION INSTRUCTIONS

## OVEN CIRCUIT // CIRCUITO DE HORNO

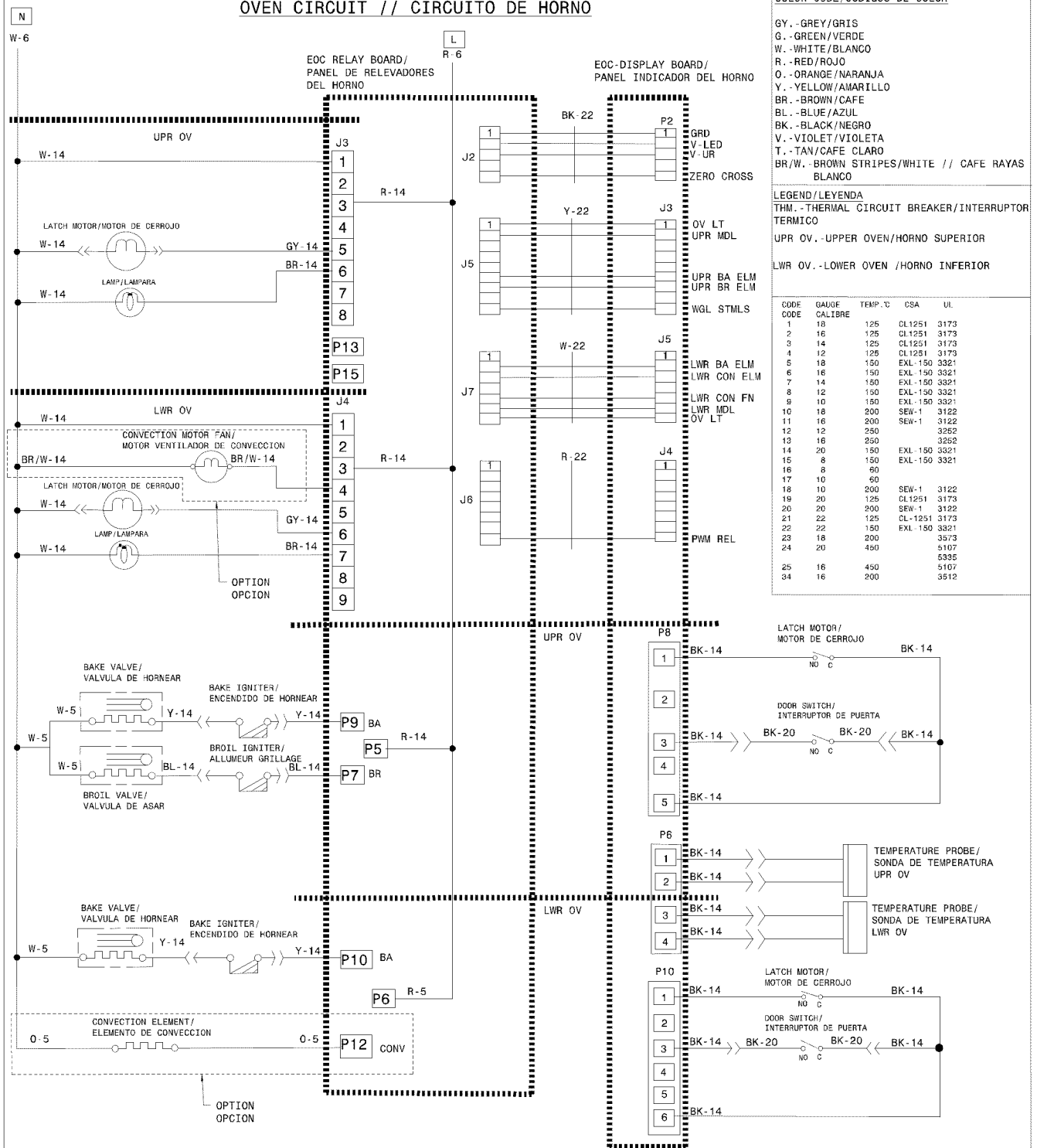

**COLOR CODE/CODIGOS DE COLOR**

GY.-GREY/GRIS  
 G.-GREEN/VERDE  
 W.-WHITE/BLANCO  
 R.-RED/ROJO  
 O.-ORANGE/NARANJA  
 Y.-YELLOW/AMARILLO  
 BR.-BROWN/CAFE  
 BL.-BLUE/AZUL  
 BK.-BLACK/NEGRO  
 V.-VIOLET/VIOLETA  
 T.-TAN/CAFE CLARO  
 BR/W. BROWN STRIPES/WHITE // CAFE RAYAS BLANCO

**LEGEND/LEYENDA**

THM.-THERMAL CIRCUIT BREAKER/INTERRUPTOR TERMICO  
 UPR OV.-UPPER OVEN/HORNO SUPERIOR  
 LWR OV.-LOWER OVEN /HORNO INFERIOR

CODE CODE	GUAGE CALIBRE	TEMP. °C	CSA	UL
1	10	125	CL1251	3173
2	16	125	CL1251	3173
3	14	125	CL1251	3173
4	12	125	CL1251	3173
5	18	150	EXL-150	3321
6	16	150	EXL-150	3321
7	14	150	EXL-150	3321
8	12	150	EXL-150	3321
9	10	150	EXL-150	3321
10	18	200	SEW-1	3122
11	16	200	SEW-1	3122
12	12	250		3252
13	16	250		3252
14	20	150	EXL-150	3321
15	8	150	EXL-150	3321
16	8	60		
17	10	60		
18	10	200	SEW-1	3122
19	20	125	CL1251	3173
20	20	200	SEW-1	3122
21	22	125	CL-1251	3173
22	22	150	EXL-150	3321
23	18	200		3573
24	20	450		5107
25	16	450		5395
34	16	200		3512

**CAUTION:DISCONNECT POWER BEFORE SERVICING UNIT.**  
 LABEL ALL WIRES PRIOR TO DISCONNECTION WHEN SERVICING CONTROLS.  
 WIRINGS ERRORS CAN CAUSE IMPROPER AND DANGEROUS OPERATION.  
 VERIFY PROPER OPERATION AFTER SERVICING.

**ATENCIÓN: CORTAR LA CORRIENTE ANTES DE REALIZAR EL MANTENIMIENTO DEL ELECTRODOMESTICO.**  
 ETIQUETE TODOS LOS CABLES ANTES DE DESCONECTAR CUANDO HAGA EL SERVICIO A LOS CONTROLES.  
 ERRORES AL VOLVER A ENSAMBLAR LOS CABLES PUEDE CAUSAR FALLAS U OPERACIONES PELIGROSAS.  
 VERIFIQUE LA CORRECTA OPERACION DESPUES DEL SERVICIO.

# 30" GAS RANGE INSTALLATION INSTRUCTIONS

## COOKTOP CIRCUIT // CIRCUITO DE PLANCHA DE COCINAR

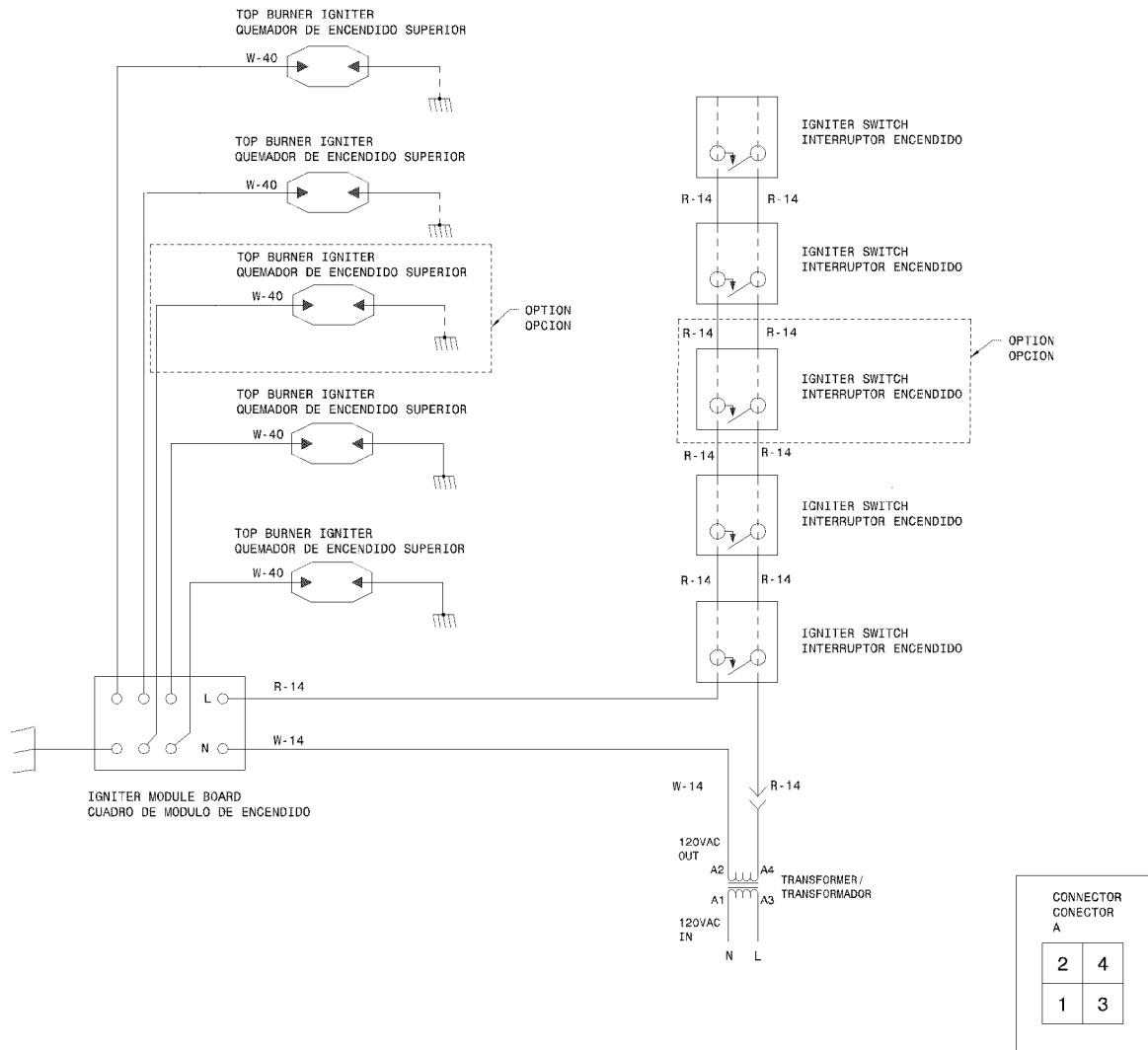

CONNECTOR  
CONECTOR  
A

2	4
1	3

CODE CODIGO	GAUGE MEDIDA	TEMP. °C	CSA	UL
1	18	125	CL1251	3173
2	16	125	CL1251	3173
3	14	125	CL1251	3173
4	12	125	CL1251	3173
5	18	150	EXL-150	3321
6	16	150	EXL-150	3321
7	14	150	EXL-150	3321
8	12	150	EXL-150	3321
9	10	150	EXL-150	3321
10	18	200	SEW-1	3122
11	16	200	SEW-1	3122
12	12	250		3252
13	16	250		3252
14	20	150	EXL-150	3321
15	8	150	EXL-150	3321
16	8	60		
17	10	60		
18	10	200	SEW-1	3122
19	20	125	CL1251	3173
20	20	200	SEW-1	3122
21	22	125		3266
22	22	150		10109
23	18	200		3573
34	16	200		3512
35	18	200		3512
37	14	200		3512
40	18	200	3204 OR/OU	10202
41	20	200		3512

**CAUTION:** DISCONNECT POWER BEFORE SERVICING UNIT.  
 LABEL ALL WIRES PRIOR TO DISCONNECTION WHEN SERVICING CONTROLS.  
 WIRINGS ERRORS CAN CAUSE IMPROPER AND DANGEROUS OPERATION.  
 VERIFY PROPER OPERATION AFTER SERVICING.

**ATENCION:** CORTAR LA CORRIENTE ANTES DE REALIZAR EL MANTENIMIENTO DEL ELECTRODOMESTICO.  
 ETIQUETE TODOS LOS CABLES ANTES DE DESCONECTAR CUANDO HAGA EL SERVICIO A LOS CONTROLES.  
 ERRORES AL VOLVER A ENSAMBLAR LOS CABLES PUEDE CAUSAR FALLAS U OPERACIONES PELIGROSAS.  
 VERIFIQUE LA CORRECTA OPERACION DESPUES DEL SERVICIO.