

# 30" GAS RANGE INSTALLATION INSTRUCTIONS

(For Models with Electric Ignition or Standing Pilot)



**INSTALLATION AND SERVICE MUST BE PERFORMED BY A QUALIFIED INSTALLER.**  
**IMPORTANT: SAVE FOR LOCAL ELECTRICAL INSPECTOR'S USE.**  
**READ AND SAVE THESE INSTRUCTIONS FOR FUTURE REFERENCE.**



**⚠ WARNING** If the information in this manual is not followed exactly, a fire or explosion may result causing property damage, personal injury or death.

## FOR YOUR SAFETY:

- Do not store or use gasoline or other flammable vapors and liquids in the vicinity of this or any other appliance.
- **WHAT TO DO IF YOU SMELL GAS:**
  - Do not try to light any appliance.
  - Do not touch any electrical switch; do not use any phone in your building.
  - Immediately call your gas supplier from a neighbor's phone. Follow the gas supplier's instructions.
  - If you cannot reach your gas supplier, call the fire department.
- Installation and service must be performed by a qualified installer, service agency or the gas supplier.



**⚠ WARNING**

- ALL RANGES CAN TIP.
- INJURY TO PERSONS COULD RESULT.
- INSTALL ANTI-TIP DEVICE PACKED WITH RANGE.
- SEE INSTALLATION INSTRUCTIONS.

Note:

29-7/8" without top trim

29-15/16" with top trim

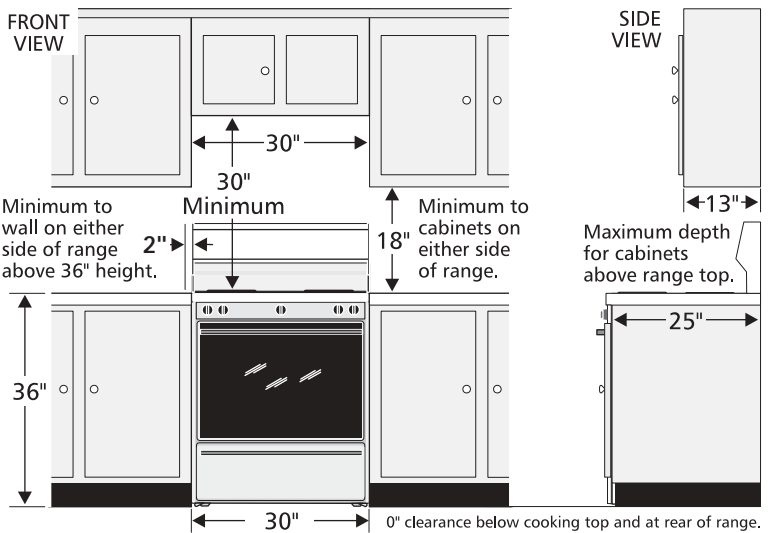
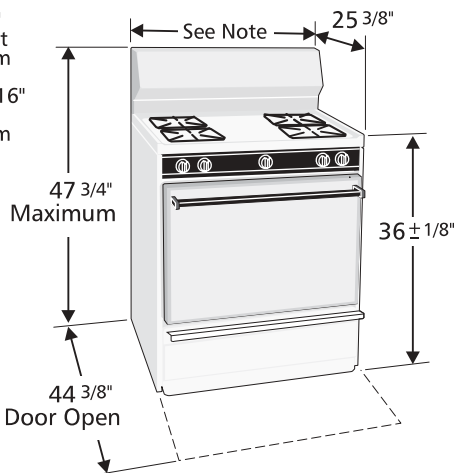

## Clearances and Dimensions

1. Location—Check location where the range will be installed. Check for proper electrical and gas supply, and the stability of the floor.
2. Dimensions that are shown must be used. Given dimensions provide minimum clearance. Contact surface must be solid and level.

# 30" GAS RANGE INSTALLATION INSTRUCTIONS

(For Models with Electric Ignition or Standing Pilot)

## Important Notes to the Installer

1. Read all instructions contained in these installation instructions before installing range.
2. Remove all packing material from the oven compartments before connecting the gas and electrical supply to the range.
3. Observe all governing codes and ordinances.
4. Be sure to leave these instructions with the consumer.

## Important Note to the Consumer

1. Keep these instructions with your owner's guide for future reference.

# IMPORTANT SAFETY INSTRUCTIONS

Installation of this range must conform with local codes or, in the absence of local codes, with the National Fuel Gas Code ANSI Z223.1—latest edition when installed in the United States. When installed in Canada, installation must conform with CAN/CGA-B149.1 and CAN/CGA-B149.2.

This range has been design certified by the American Gas Association and the Canadian Gas Association. As with any appliance using gas and generating heat, there are certain safety precautions you should follow. You will find them in the Owner's Guide, read it carefully.

- **Be sure your range is installed and grounded properly by a qualified installer or service technician.**
- **This range must be electrically grounded in accordance with local codes or, in their absence, with the National Electrical Code ANSI/NFPA No .70—latest edition when installed in the United States.** When installed in Canada, this range must be electrically grounded in accordance with CSA Standard C22.1, Canadian Electrical Code, Part 1. See Grounding Instructions on page 5.
- The installation of appliances designed for manufactured (mobile) home installation must conform with Manufactured Home Construction and Safety Standard, title 24CFR, part 3280 [Formerly the Federal Standard for Mobile Home Construction and Safety, title 24, HUD (part 280)] or when such standard is not applicable, the Standard for Manufactured Home Installation 1982 (Manufactured Home Sites, Communities and Set-ups), ANSI Z225.1/NFPA 501A—latest edition, or with local codes when installed in the United States. When installed in Canada, installation must conform with CAN/CSA-Z240 MH.

- **Before installing the range in an area covered with linoleum or any other synthetic floor covering, make sure the floor covering can withstand heat at least 90°F above room temperature without shrinking, warping or discoloring.** Do not install the range over carpeting unless you place an insulating pad or sheet of 1/4-inch thick plywood between the range and carpeting.
- **Make sure the wall coverings around the range can withstand the heat generated by the range.**
- **Do not obstruct the flow of combustion air at the oven vent nor around the base or beneath the lower front panel of the range.** Avoid touching the vent openings or nearby surfaces as they may become hot while the oven is in operation. This range requires fresh air for proper burner combustion.

**⚠ WARNING** Never leave children alone or unattended in the area where an appliance is in use. As children grow, teach them the proper, safe use of all appliances. Never leave the oven door open when the range is unattended.

**⚠ WARNING** Stepping, leaning or sitting on the doors or drawers of this range can result in serious injuries and can also cause damage to the range.

- **Do not store items of interest to children in the cabinets above the range.** Children could be seriously burned climbing on the range to reach items.
- **To eliminate the need to reach over the surface burners, cabinet storage space above the burners should be avoided.**
- **Adjust surface burner flame size so it does not extend beyond the edge of the cooking utensil.** Excessive flame is hazardous.
- **Do not use the oven as a storage space.** This creates a potentially hazardous situation.
- **Never use your range for warming or heating the room.** Prolonged use of the range without adequate ventilation can be dangerous.
- **Do not store or use gasoline or other flammable vapors and liquids near this or any other appliance.** Explosions or fires could result.
- **Reset all controls to the "off" position after using a programmable timing operation.**

## FOR MODELS WITH SELF-CLEAN FEATURE:

- **Remove broiler pan, food and other utensils before self-cleaning the oven.** Wipe up excess spillage. Follow the precleaning instructions in the Owner's Guide.

# 30" GAS RANGE INSTALLATION INSTRUCTIONS

(For Models with Electric Ignition or Standing Pilot)

**⚠ WARNING** DO NOT MAKE ANY ATTEMPT TO OPERATE THE ELECTRIC IGNITION OVEN DURING AN ELECTRICAL POWER FAILURE. RESET ALL OVEN CONTROLS TO "OFF" IN THE EVENT OF A POWER FAILURE.

The electric ignitor will automatically re-ignite the oven burner when power resumes if the oven thermostat control was left in the "ON" position.

When an electrical power failure occurs during use, the surface burners will continue to operate.

During a power outage, the surface burners can be lit with a match. Hold a lighted match to the burner, then slowly turn the knob to the LITE position. Use extreme caution when lighting burners this way.

**Note:** On pilot models, the surface and oven burners will operate normally during a power outage.

## Before Starting

### Tools You Will Need

#### For leveling legs:

- Socket wrench (1-3/8" hex) or channel lock pliers

#### For gas supply connection:

- Pipe wrench

#### For burner flame adjustment:

- Phillips® head and blade-type screwdrivers

#### For gas conversion (LP/Propane or Natural):

- Open end wrench - 1/2"

### Additional Materials You Will Need

- Gas line shut-off valve
- Pipe joint sealant that resists action of LP/Propane gas
- Flexible metal appliance conduit (1/2" NPT x 3/4" or 1/2" I.D.) must be AGA/CGA design certified. Because solid pipe restricts moving the range we recommend using this flexible conduit (4 to 5 foot length).
- (2) Flare union adapters (1/2" NPT x 3/4" or 1/2" I.D.) for connecting flexible appliance conduit.

## Normal Installation Steps

### Before Proceeding:

Your range has been preset at the factory for use with Natural or LP/Propane gas. The factory orifice setting is indicated on the serial plate. Be sure the range is adjusted for proper type gas before continuing. See instructions for "Gas Conversion" if adjustments are necessary.

### 1. Install Anti-Tip Bracket(s). (See page 10.)

**2. Provide an adequate gas supply.** This unit is designed to operate on 4" natural gas or 10" LP/Propane manifold pressure. A convertible pressure regulator is connected to the manifold and MUST be connected in series with the gas supply line regardless of which type of fuel is being used.

Care must be taken during installation of range not to obstruct the flow of combustion and ventilation air.

*For proper operation*, the maximum inlet pressure to the regulator should be no more than 14 inches of water column pressure. The inlet pressure to the regulator must be at least 1 inch greater than regulator manifold pressure. Examples: If regulator is set for natural gas 4 inch manifold pressure, inlet pressure must be at least 5 inches; if regulator has been converted for LP/Propane gas 10 inch manifold pressure, inlet pressure must be at least 11 inches.

The gas supply line should be 1/2" or 3/4" I.D.

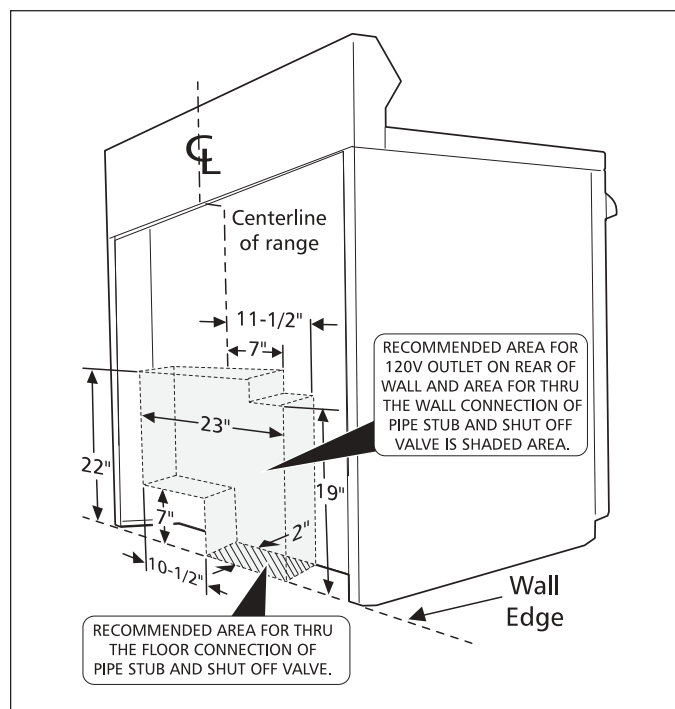

**3. Seal the openings.** Seal any openings in the wall behind the range and in the floor under the range after gas supply line is installed.

# 30" GAS RANGE INSTALLATION INSTRUCTIONS

(For Models with Electric Ignition or Standing Pilot)

4. **Connect the range to the gas supply.** To prevent leaks, put a pipe joint sealant on all male (outside) pipe threads.

Your regulator is in one of the two locations shown below.

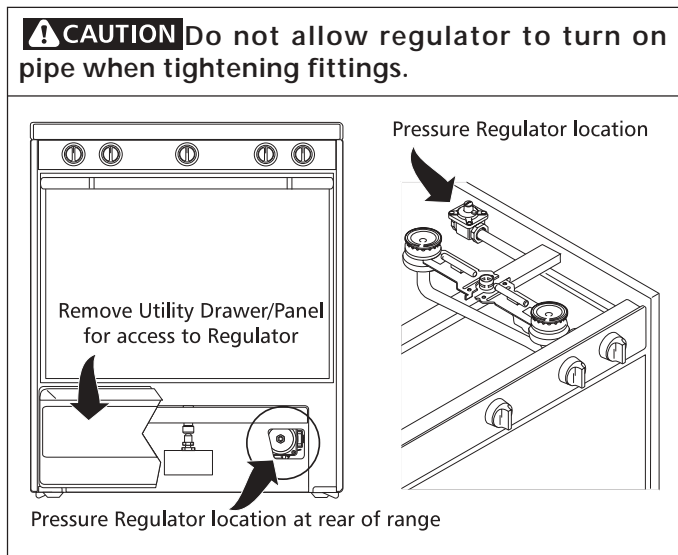

## Gas connection for electric ignition models

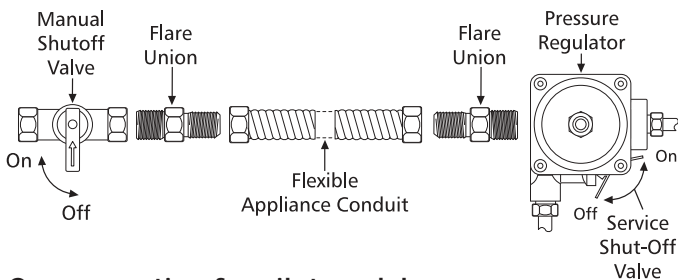

## Gas connection for pilot models

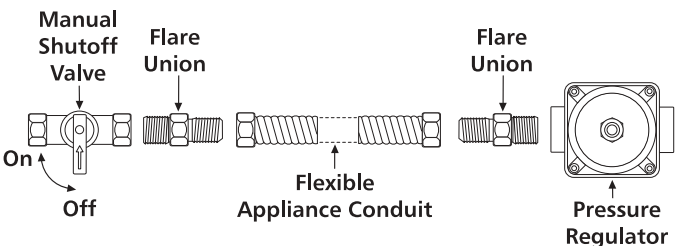

- Install a manual gas shut-off valve to gas supply line in an easily-accessible location outside of the range. Be sure you know how and where to shut-off the gas supply to the range.
- Install 1/2" flare union adapter to pressure regulator.
- Attach appliance conduit to flare union on regulator.
- Install flare union adapter to external manual shut-off valve.
- Attach appliance conduit to flare union on shut-off valve.
- Make sure service shut-off valve on pressure regulator is in "ON" position.

- Check for leaks. Turn the gas supply on to the range and use a liquid leak detector at all joints and conduits to check for leaks in the system.

**WARNING** Do not use a flame to check for gas leaks.

## Checking Manifold Gas Pressure

Disconnect the range and its individual shut-off valve from the gas supply piping system during any pressure testing of that system at test pressures greater than 14" of water column pressure (approximately 1/2" psig).

The appliance must be isolated from the gas supply piping system by closing its individual manual shut-off valve during any pressure testing of the gas supply piping system at test pressures equal to or less than 14" of water column pressure (approximately 1/2" psig).

If it should be necessary to check the manifold gas pressure, connect manometer (water gauge) or other pressure device to the top burner right rear orifice. Using a rubber hose with inside diameter of approximately 1/4," hold tubing down tight over orifice. Turn burner valve on.

For an accurate pressure check have at least two (2) other top burners burning. Be sure the gas supply (inlet) pressure is at least one inch above specified range manifold pressure. The gas supply pressure should never be over 14" water column. When properly adjusted for Natural Gas the manifold pressure is 4." For LP/Propane Gas the manifold pressure is 10."

## 5. Read electrical connection details below and connect electricity to range.

**WARNING** Before servicing, disconnect electrical supply at circuit breaker, fuse or power cord.

Electric Requirements: An individual, properly grounded and polarized branch circuit protected by a 15 amp. circuit breaker or time delay fuse. See serial plate for proper voltage.

Extension Cord Precautions: Because of potential safety hazards under certain conditions, we strongly recommend against the use of any extension cord. However, if you still elect to use an extension cord, it is absolutely necessary that it be a UL listed 3-wire grounding type appliance extension cord and that the current carrying rating of the cord in amperes be equivalent to or greater than the branch circuit rating. Such extension cords are obtainable through your local service organization.

**WARNING PLEASE READ CAREFULLY!** For personal safety, this product must be properly grounded.

# 30" GAS RANGE INSTALLATION INSTRUCTIONS

(For Models with Electric Ignition or Standing Pilot)

## Grounding Instructions

The power cord of this appliance is equipped with a 3-prong (grounding) plug which mates with a standard 3-prong grounding wall receptacle to minimize the possibility of electric shock hazard from this appliance. The customer should have the wall receptacle and circuit checked by a qualified electrician to make sure the receptacle is properly grounded and polarized.

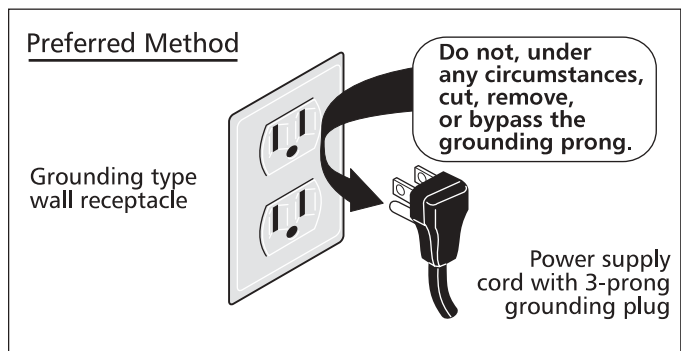

Where a standard two-prong wall receptacle is encountered, it is the personal responsibility and obligation of the customer to have it replaced with a properly grounded three-prong wall receptacle.

**DO NOT, UNDER ANY CIRCUMSTANCES, CUT OR REMOVE THE THIRD (GROUND) PRONG FROM THE POWER CORD.**

This range is equipped with either an electric ignition system or standing pilots. To determine which system your range has, lift the cooktop. Models with standing pilots will have pilot cups as pictured in step 6b. Follow the appropriate instructions for your model.

## Operation of Surface Burners

This range is equipped with one of the burner types shown below.

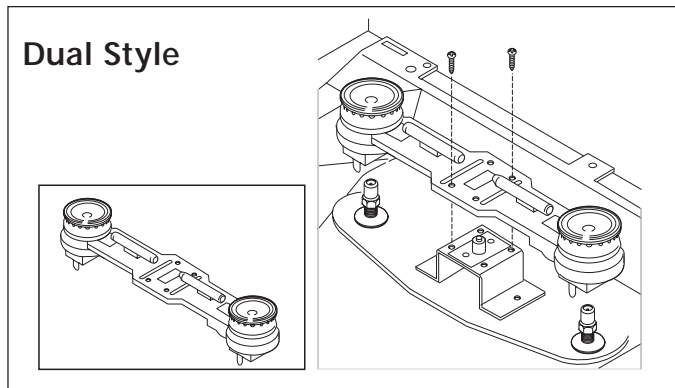
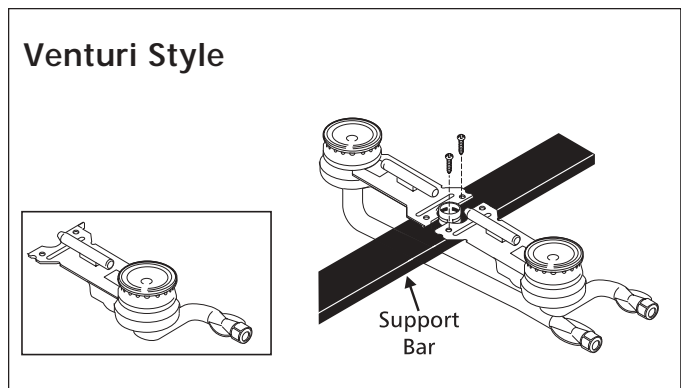

## 6a. Electric Ignition Surface Burners

Operation of electric igniters should be checked after range and supply line connectors have been carefully checked for leaks and range has been connected to electric power. To check for proper lighting, push in and turn a surface burner knob to the LITE position. You will hear the igniter sparking. The surface burner should light when gas is available to the top burner. Each burner should light within four (4) seconds in normal operation after air has been purged from supply lines. Visually check that burner has lit. Once the burner lights, the control knob should be rotated out of the LITE position. There are separate ignition devices for each burner. Try each knob separately until all burner valves have been checked.

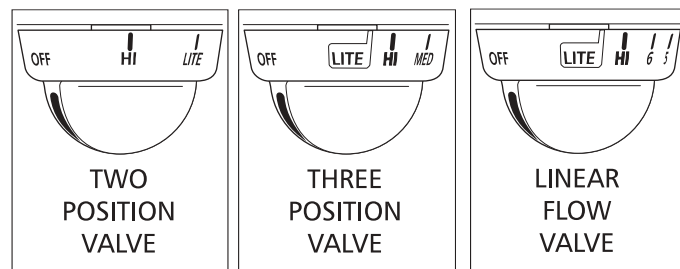

**Note:** Knob styles may vary from those pictured above.

# 30" GAS RANGE INSTALLATION INSTRUCTIONS

(For Models with Electric Ignition or Standing Pilot)

## 6b. Standing Pilot Surface Burners

After range and supply line conduits have been carefully checked for leaks, purge air from the system. The standing pilots must be lit immediately, proceed as follows:

1. Raise the cooktop.
2. Light both pilots with a match. When both pilots are lit, adjust the top pilot adjustment until the pilots are approximately 1/8" above the pilot cage with a very slight yellow tip.

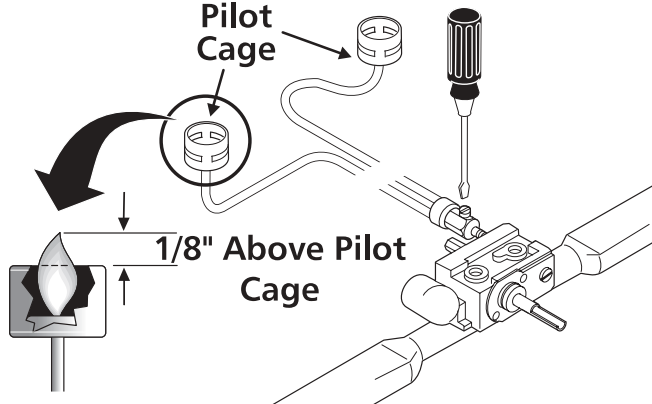

### Check Surface Burners

To check for proper lighting, push in and turn a surface burner knob to the LITE position. Each burner should light within four (4) seconds in normal operation. Once the burner lights, the knob should be rotated out of the LITE position. Try each knob separately until all burner valves have been checked.

## 7. Air adjustment (Venturi Style Burners Only)

**Note:** Air mixture adjustment is not required on Dual or Snap-in style top burners.

The air shutter (adjustment) for each of the four top burners is located at the open end of the venturi tube and sets on the hood of the valve.

Should the air shutter need adjusting, rotate the air shutter to allow more or less air into the burner tubes as needed.

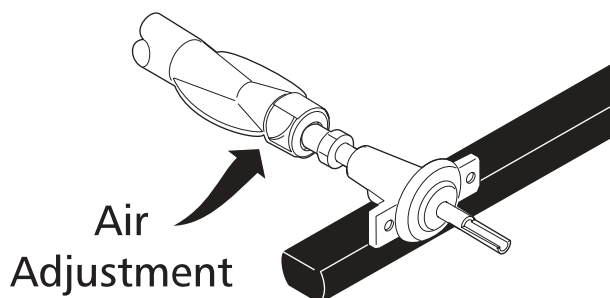

If the air is properly adjusted, the flame will be steady, relatively quiet, and have approximately 1/2" sharp blue cone. (Usually about the center of air shutter's adjustment.)

If the flame is yellow in color, increase air shutter opening size. If the flame is a distinct blue, but lifting away from the burner, reduce the air shutter opening size.

## 8. Adjust the "LOW" Setting of Surface Burner Valve (Three Position and Linear Flow Valves):

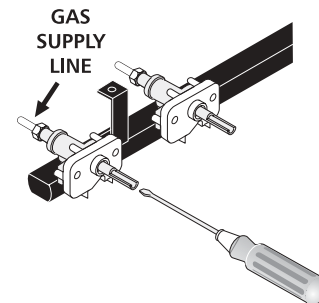

- a) Turn control to LITE until burner ignites.
- b) Quickly turn knob to LOWEST POSITION.
- c) If burner goes out, readjust valve as follows:

Reset control to OFF. Remove the surface burner control knob, insert a thin-bladed screw driver into the hollow valve stem and engage the slotted screw inside. Flame size can be increased or decreased with the turn of the screw. Adjust flame until you can quickly turn knob from LITE to LOWEST POSITION without extinguishing the flame. Flame should be as small as possible without going out.

## Operation of Oven Burners and Oven Adjustments

### 9a. Electric Ignition Burners

Operation of electric igniters should be checked after range and supply line connectors have been carefully checked for leaks and range has been connected to electric power.

The oven burner is equipped with an electric control system as well as an electric oven burner igniter. If your model is equipped with a waist-high broil burner, it will also have an electric burner igniter. These control systems require no adjustment. When the oven is set to operate, current will flow to the igniter. It will "glow" similar to a light bulb. When the igniter has reached a temperature sufficient to ignite gas, the electrically controlled oven valve will open and flame will appear at the oven burner. There is a time lapse from 30 to 60 seconds after the thermostat is turned ON before the flame appears at the oven burner. When the oven

# 30" GAS RANGE INSTALLATION INSTRUCTIONS

(For Models with Electric Ignition or Standing Pilot)

reaches the dial setting, the glowing igniter will go off. The burner flame will go "out" in 20 to 30 seconds after the igniter goes "OFF." To maintain any given oven temperature, this cycle will continue as long as the dial (or display) is set to operate.

After removing all packing materials and literature from the oven:

- Set oven to BAKE at 300°F. See Owner's Guide for operating instructions.
- Within 60 seconds the oven burner should ignite. Check for proper flame, and allow the burner to cycle once. Reset controls to off.
- If your model is equipped with a waist-high broiler, set oven to BROIL. See Owner's Guide for operating instructions.
- Within 60 seconds the broil burner should ignite. Check for proper flame. Reset controls to off.

## 9b. Standing Pilot Oven Burner

To light the oven pilot, proceed as follows:

Turn the oven thermostat knob to OFF. Remove oven bottom, see step 10 for instructions on removing the oven bottom. Light the oven pilot with a match. The oven pilot should burn with a stable flame after a few seconds operation and should have a small flame visible only at the opening in the top of the pilot assembly.

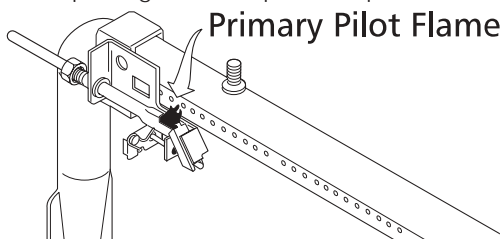

Turn oven thermostat knob to 300°F. The oven pilot should now be larger with the flame extending down the slanted ramp and burning against a small metal bulb.

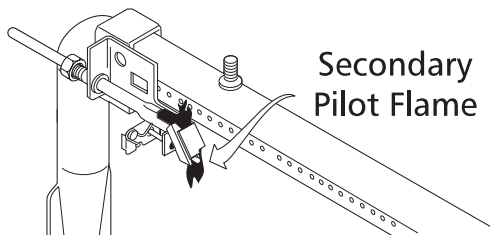

After 20-40 seconds, the main oven burner should ignite and burn until the oven temperature has reached 300°F. At that time, the oven pilot should get smaller, moving up away from the metal bulb which will turn off the main oven burner after 20-40 seconds.

The oven burner will continue to turn off and on to maintain oven temperature.

## 10. Air Shutter-Oven Burner

The approximate flame length of the oven burner is 1 inch (distinct inner, blue flame).

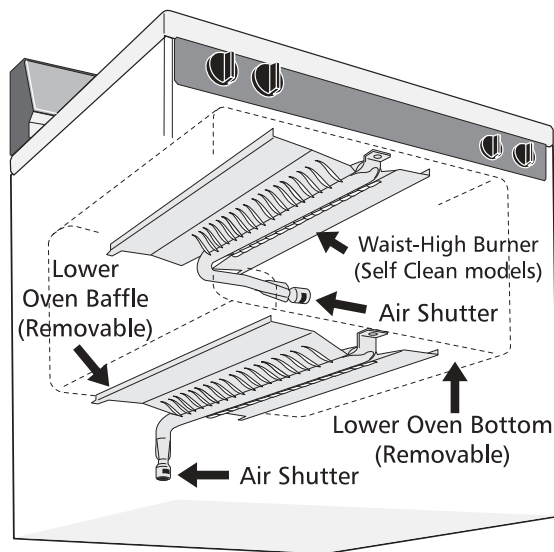

To determine if the oven burner flame is proper, remove the oven bottom and burner baffle and set the oven to bake at 300°F.

To remove the oven bottom, remove oven hold down screws at rear of oven bottom. Pull up at rear, disengage front of oven bottom from oven front frame, and pull the oven bottom out of the oven. Remove burner baffle so that the burner flame can be observe.

If the flame is yellow in color, increase air shutter opening size. (See "2" in illustration below.) If the flame is a distinct blue, reduce the air shutter opening size.

To adjust loosen lock screw (see "3" illustration below), reposition air shutter, and tighten lock screw. Replace oven bottom.

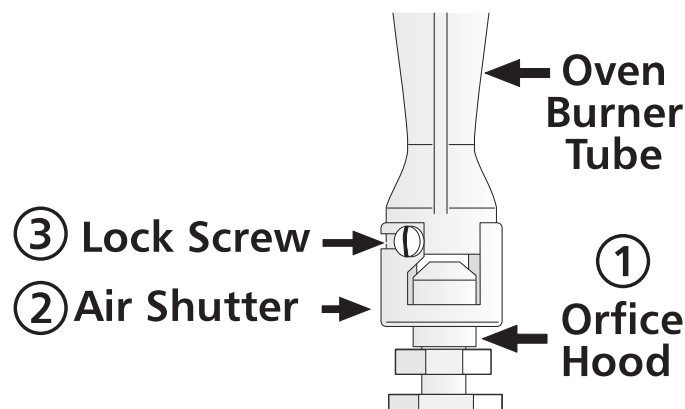

# 30" GAS RANGE INSTALLATION INSTRUCTIONS

(For Models with Electric Ignition or Standing Pilot)

## 11. Air Shutter-Broil Burner (if equipped)

The approximate flame length of the broil burner is 1 inch (distinct inner, blue flame).

To determine if the broil burner flame is proper, set the oven to broil.

If the flame is yellow in color, increase air shutter opening size. (See "2" in illustration above.) If the flame is a distinct blue, reduce the air shutter opening size.

To adjust, loosen lock screw (see "3" in illustration above), reposition air shutter, and tighten lock screw.

## 12. Make Sure Range is Level.

Level the range by placing a level horizontally on an oven rack. Check diagonally from front to back, then level the range by either adjusting the leveling legs or by placing shims under the corners of the range as needed.

## 13. After installation is complete, make sure all controls are left in the OFF position.

## Model and Serial Number Location

The serial plate is located under the lift-up cooktop in the burner pan.

When ordering parts for or making inquiries about your range, always be sure to include the model and serial numbers and a lot number or letter from the serial plate on your range.

Your serial plate also tells you the rating of the burners, the type of fuel and the pressure the range was adjusted for when it left the factory.

## Before You Call for Service

Check to make sure the house fuses or circuit breakers for your range are not blown or open. Refer to the Avoid Service Checklist and operating instructions in your Owner's Guide. It may save you time and expense. The list includes common occurrences that are not the result of defective workmanship or materials in this appliance.

Refer to the warranty in your Owner's Guide for our toll-free service number and address. Please call or write if you have inquiries about your range product and/or need to order parts.

## Care, Cleaning and Maintenance

Refer to the Owner's Guide for operating and cleaning instructions.

If removing the range is necessary for cleaning or maintenance, shut off gas supply. Disconnect the gas and electrical supply. If the gas or electrical supply is inaccessible, lift the unit slightly at the front and pull out away from the wall. Pull only as far as necessary to disconnect the gas and electrical supply. Finish removing the unit for servicing and cleaning. Reinstall in reverse order making sure to level the range and check gas connections for leaks. See page 10, paragraph 5 for proper anchoring instructions.

## Gas Conversion

This range was adjusted for Natural or LP/Propane gas, as specified on the serial plate.

Your regulator is in one of the two locations shown. **Do not remove the Pressure Regulator.**

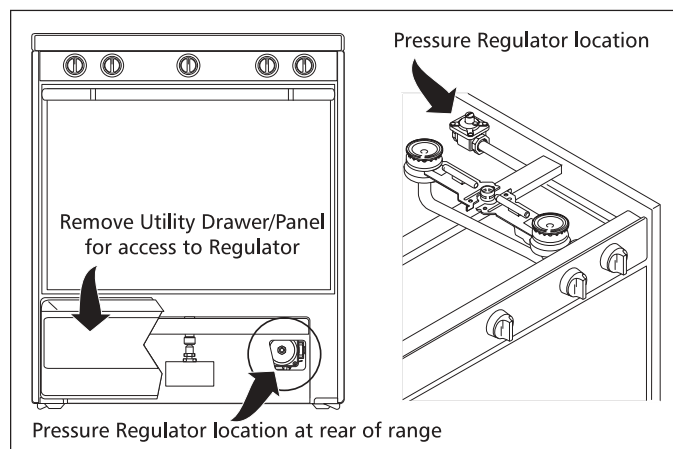

### 1a. Convert the Pressure Regulator - Self-Cleaning Electric Ignition Models

- Unscrew the cap from the pressure regulator. Be sure spring stays in place.
- Turn the cap to the desired setting (see illustration below).
- Replace the cap of the regulator. The letters corresponding with the type of gas being used should be visible on the exposed end of the cap.

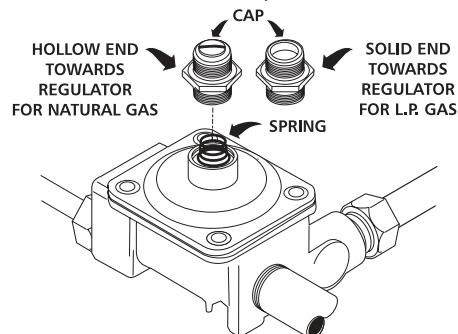



# 30" GAS RANGE INSTALLATION INSTRUCTIONS

(For Models with Electric Ignition or Standing Pilot)

## 1b. Convert the Pressure Regulator - Non Self-Cleaning Electric Ignition Models

- Using a screwdriver or coin, turn the cap counterclockwise to release from the pressure regulator. Be sure the O-ring gasket stays in place.
- Turn the cap over and place into the slots. Turn clockwise to lock in position. The letters corresponding with the type of gas being used should be visible on the exposed end of the cap.

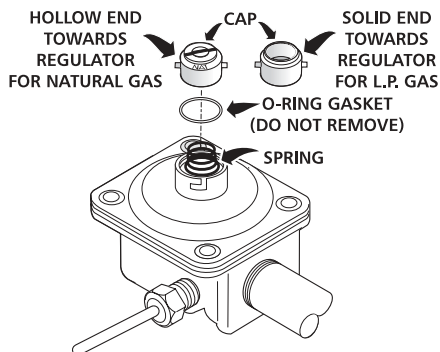

## 1c. Convert the Pressure Regulator - Non-Self-Cleaning Standing Pilot Models

- Remove the cap from the pressure regulator.
- Remove the plunger from the cap.
- Turn the plunger with the enlarged end down for LP/Propane use. Turn the plunger with the small end down for Natural gas use. (See illustration below.)
- Replace the plunger inside the cap.
- Replace the cap.

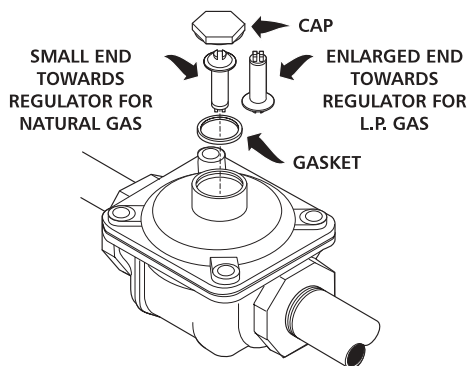

Remove the thermostat knob to access the selector key. Check the selector key on the thermostat to be certain the pointer is turned to select the proper fuel being used (Natural or LP/Propane). Replace the thermostat knob.

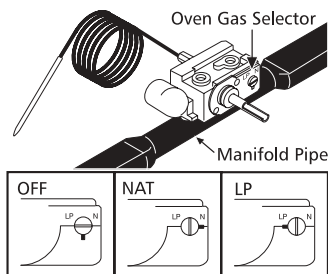

## 2. Convert Surface Burner Valves - All Models

- Lift and lock cooktop to gain access to the surface burner spuds. Surface burner spuds for models with venturi burners are located in the front of the burner box. For models with dual or snap-in burners, the spuds are in the bottom of the burner box.
- Using 1/2" wrench, adjust surface burner spud as follows. For Natural to LP/Propane conversion tighten spud down clockwise until snug (approximately 2-1/2 turns). This restricts the flow of gas through the spuds to only that allowed by the hollow LP/Propane metering pin. **Do not over tighten.**

For LP/Propane to Natural conversion, loosen spuds counter-clockwise (approximately 2-1/2 turns). This increases the flow of gas around the metering pin.

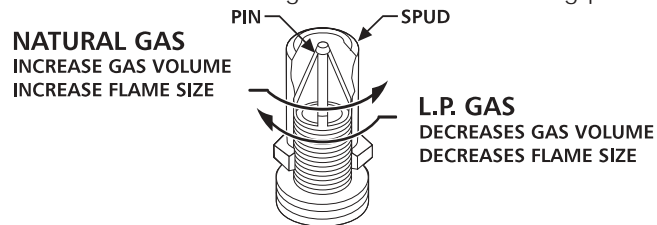

## 3. Convert Oven Burner Spud

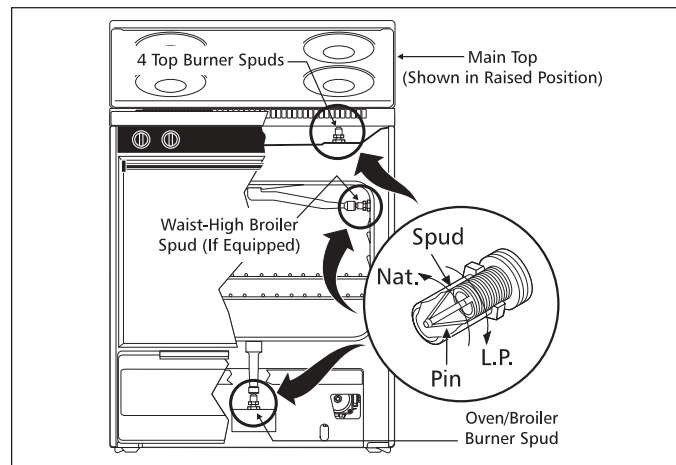

- Remove oven bottom and oven burner baffle located on top of burner. To remove oven bottom, remove oven hold down screws at rear of oven bottom. Pull up at rear, disengage front to oven bottom from oven front-frame, and pull the oven bottom straight out of the oven. Remove nut attaching burner baffle to oven burner.
- Using 1/2" wrench, adjust oven burner spud as follows. For Natural to LP/Propane conversion tighten spud down clockwise until snug (approximately 2-1/2 turns). This restricts the flow of gas through the spuds to only that allowed by the hollow LP/Propane metering pin. **Do not over tighten.**

# 30" GAS RANGE INSTALLATION INSTRUCTIONS

(For Models with Electric Ignition or Standing Pilot)

For LP/Propane to Natural conversion, loosen spuds counter-clockwise (approximately 2-1/2 turns). This increases the flow of gas around the metering pin.

## 4. Convert Broil Burner Spud (if equipped)

- a. Using 1/2" wrench, adjust broil burner spud as follows. For Natural to LP/Propane conversion tighten spud down clockwise until snug (approximately 2-1/2 turns). This restricts the flow of gas through the spuds to only that allowed by the hollow LP/Propane metering pin. **Do not over tighten.**

For LP/Propane to Natural conversion, loosen spuds counter-clockwise (approximately 2-1/2 turns). This increases the flow of gas around the metering pin.

**After conversion is complete, follow normal instructions on page 3 for installation and burner operation/adjustments. For models with linear flow and 3 position valves, the low "simmer" setting must be adjusted after conversion.**

## Anti-Tip Brackets Installation Instructions

### Important Safety Warning

To reduce the risk of tipping of the range, the range must be secured to the floor by properly installed anti-tip brackets and screws packed with the range. Failure to install the anti-tip brackets will allow the range to tip over if excessive weight is placed on an open door or if a child climbs upon it. Serious injury might result from spilled hot liquids or from the range itself.

Follow the instructions below to install the anti-tip brackets.

If range is ever moved to a different location, the anti-tip brackets must also be moved and installed with the range. To check for proper installation, see step 5.

### Tools Required:

- 5/16" Nutdriver or Flat Head Screwdriver
- Adjustable Wrench
- Electric Drill
- 3/16" Diameter Drill Bit
- 3/16" Diameter Masonry Drill Bit (if installing in concrete)

### Two Piece Anti-Tip Bracket

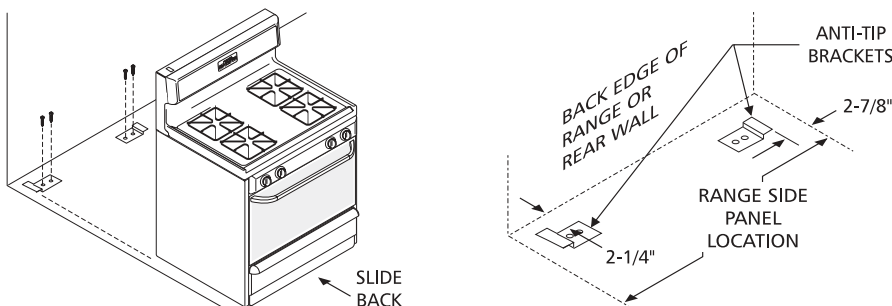

## Anti-Tip Brackets Installation Instructions

Brackets attach to the floor at the back of the range to hold both rear leg levelers. When fastening to the floor, be sure that screws do not penetrate electrical wiring or plumbing. The screws provided will work in either wood or concrete. The anti-tip brackets are attached to the back of the range.

1. Unfold paper template and place it flat on the floor with the back and side edges positioned exactly where the back and sides of range will be located when installed. (Use the diagram below to locate brackets if template is not available.)
2. Mark on the floor the location of the 4 mounting holes shown on the template. For easier installation, 3/16" diameter pilot holes 1/2" deep can be drilled into the floor.
3. Remove template and place brackets on floor with turned up flange to the front. Line up holes in brackets with marks on floor and attach with 4 screws provided. Brackets must be secured to solid floor. If attaching to concrete floor, first drill 3/16" dia. pilot holes using a masonry drill bit.
4. Level range if necessary, by adjusting 4 leg levelers with wrench. (See Figure 1 below.) A minimum clearance of 1/8" is required between the bottom of the range and the rear leg levelers to allow room for the anti-tip brackets.
5. Slide range into place making sure rear legs are trapped by ends of brackets. Range may need to be shifted slightly to one side as it is being pushed back to allow rear legs to align with brackets. Remove lower panel, storage drawer or open broiler compartment to inspect brackets. You may also grasp the top rear edge of the range and carefully attempt to tilt it forward to make sure range is properly anchored.

Figure 1

