



LG

<http://aic.lgservice.com>

SXS REFRIGERATOR **SERVICE MANUAL**

CAUTION

**PLEASE READ CAREFULLY THE SAFETY PRECAUTIONS OF THIS MANUAL
BEFORE CHECKING OR OPERATING THE REFRIGERATOR.**

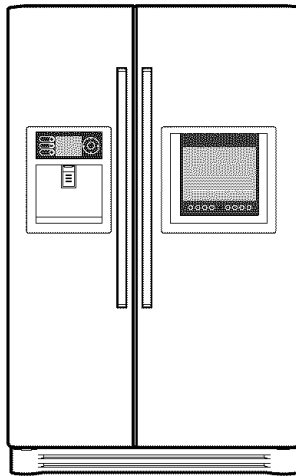

MODEL : LSC27990TT

COLOR : TITANIUM

CONTENTS

WARNINGS AND PRECAUTIONS FOR SAFETY	3
SPECIFICATIONS.....	4
PARTS IDENTIFICATION	5
HOW TO INSTALL THE REFRIGERATOR	6
HOW TO ADJUST DOOR HEIGHT.....	6
FILTER	7
HOW TO CONTROL THE ICEMAKER WATER SUPPLY.....	8
MICOM FUNCTION	9
EXPLANATION OF MICOM CIRCUIT	22
EXPLANATION OF PWB CIRCUIT	22
PWB PARTS DIAGRAM AND LIST.....	37
PWB CIRCUIT DIAGRAM.....	43
ICEMAKER AND DISPENSER WORKING PRINCIPLES AND REPAIR	45
WORKING PRINCIPLES.....	45
FUNCTION OF ICEMAKER	46
CIRCUIT	48
TROUBLE DIAGNOSIS.....	49
TROUBLESHOOTING	49
FAULTS	59
COOLING CYCLE HEAVY REPAIR.....	76
HOW TO DEAL WITH CLAIMS	83
TV-RADIO	88
SAFETY PRECAUTIONS.....	88
FEATURE	88
CONTROLS.....	89
REMOTE CONTROL KEY FUNCTIONS	90
TROUBLESHOOTING	91
BLOCK DIAGRAM.....	92
TV PART DISASSEMBLE	93
HOW TO DISASSEMBLE AND ASSEMBLE	94
DOOR.....	94
HANDLE.....	95
FAN SHROUD GRILLE	95
WATER VALVE DISASSEMBLY METHOD	96
FAN and FAN MOTOR DISASSEMBLY METHOD.....	96
DISPENSER.....	97
EXPLODED VIEW	99
REPLACE PARTS LIST.....	106

WARNINGS AND PRECAUTIONS FOR SAFETY

Please observe the following safety precautions to use the refrigerator safely and correctly and to prevent accident or injury when servicing.

1. Be careful of an electric shock. Disconnect the power cord from wall outlet and wait for more than three minutes before replacing PWB parts. Shut off the power whenever replacing and repairing electric components.
2. When connecting the power cord, please wait for more than five minutes after the power cord was disconnected from the wall outlet.
3. Check if the power cord is pinched between the refrigerator and the wall. If the plug or cord is damaged, it could cause a fire or an electric shock
4. If the wall outlet is overloaded, it may cause a fire. Use a dedicated circuit for the refrigerator.
5. Make sure the outlet is properly grounded. Particularly in a wet or damp area.
6. Use standard electrical components.
7. Remove dust and foreign materials from the housing and connecting parts.
8. Do not fray, damage, run over, kink, bend, pull out, or twist the power cord.
9. Check for evidence of moisture intrusion in the electrical components. Replace the parts or mask with insulation tape if moisture intrusion was confirmed.
10. Do not insert fingers or tools into the icemaker. The geared motor drive could cause an injury or damage to tools or the icemaker .
11. Do not suggest that customers repair their refrigerator themselves. This work requires special tools and knowledge. Non-professionals could cause fire, injury, or damage to the product.
12. Do not store flammable materials such as ether, benzene, alcohol, chemicals, or gas.
13. Do not put anything on top of the refrigerator, especially something containing water, like a vase.
14. Do not put glass bottles with full of water into the freezer. The contents will freeze and break the glass bottles.
15. When you scrap or discard the refrigerator, remove the doors and dispose of it where children are not likely to play in or around it.
16. This is a consumer grade product. It is not intended for precise storage of medication.

SPECIFICATIONS

1. Ref No. : GR-G277STSA(LSC27990TT)

ITEMS	SPECIFICATIONS	ITEMS	SPECIFICATIONS
DIMENSIONS	908 x 896 x 1771 mm	DRIER	MOLECULAR SIEVE XH-7
W x D x H	(35 ¹¹ / ₁₆ X35 ⁵ / ₁₆ X69 ¹¹ / ₁₆ in.)	CAPILLARY TUBE	ID Ø0.83
NET WEIGHT	145 kg (319.7 lbs.)	FIRST DEFROST	4 - 5 Hours
COOLING SYSTEM	Fan Cooling	DEFROST CYCLE	13 - 15 Hours
TEMPERATURE CONTROL	Micom Control	DEFROSTING DEVICE	Heater, Sheath
DEFROSTING SYSTEM	Full Automatic	ANTI-SWEAT HEATER	Dispenser Duct Door Heater
	Heater Defrost		Dispenser Heater
INSULATION	Cyclo-Pentane	ANTI-FREEZING HEATER	Water Tank Heater
COMPRESSOR	PTC Starting Type		Damper Heater
EVAPORATOR	Fin Tube Type	FREEZER LAMP	40W (1 EA)
CONDENSER	Wire Condenser	REFRIGERATOR LAMP	40W (4 EA)
REFRIGERANT	R134a (185g) (6 ¹ / ₂ oz.)	DISPENSER LAMP	15W (1 EA)
LUBRICATING OIL	FREOL @ 10G (320 cc)		

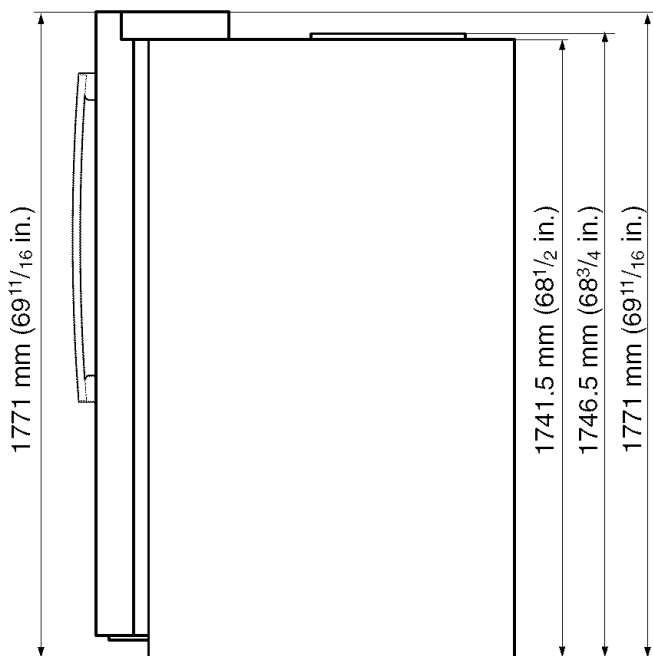

Front View

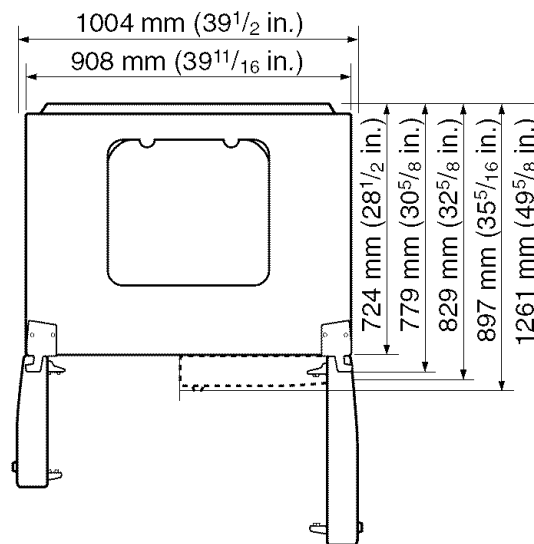

Top View

PARTS IDENTIFICATION

1. Ref No. : GR-G277STSA(LSC27990TT)

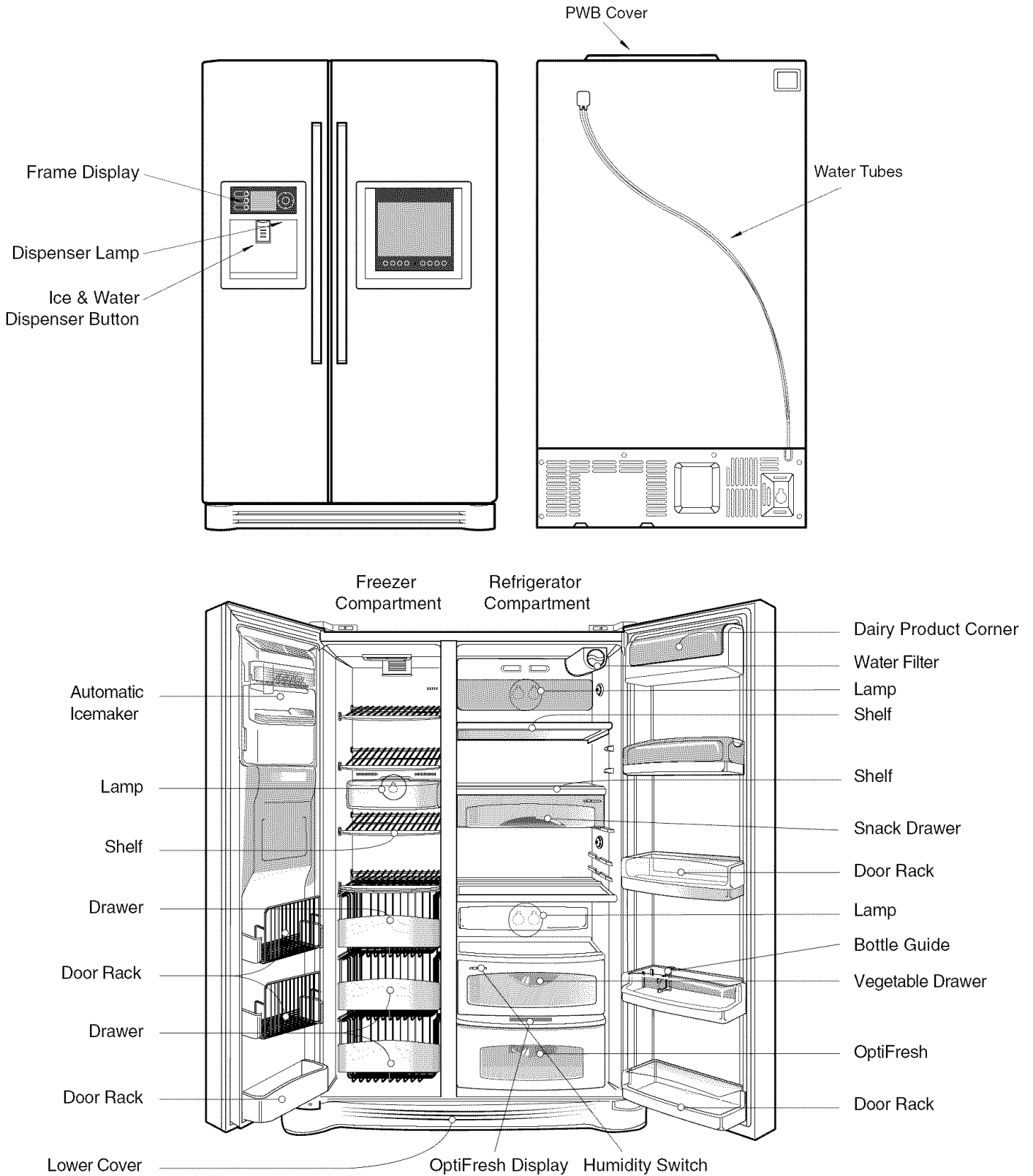

HOW TO INSTALL REFRIGERATOR

1. How to Adjust Door Height of Refrigerator

■ Make the refrigerator level first. (If the refrigerator is not installed on a flat floor, the height of freezer and refrigerator door may not be the same.)

1) If the freezer door is lower than the refrigerator door:

2) If the freezer door is higher than the refrigerator door:

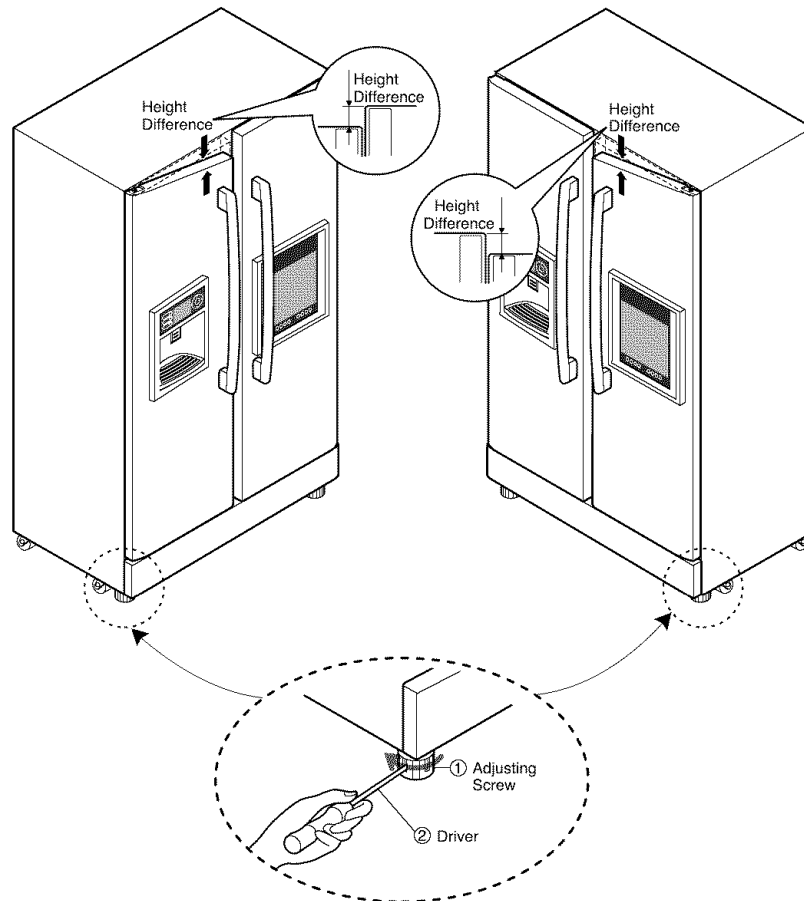

Insert a driver ② into the groove ① of the adjusting screw and turn in the direction of the arrow (clockwise) until the refrigerator is level.

Insert a driver ② into the groove ① if the adjusting screw and turn in the direction of the arrow (clockwise) until the refrigerator is level.

3) When the refrigerator door is lower than the freezer door

Adjust the level when the refrigerator door is lower than the freezer door during the use of the refrigerator.

- (1) Using the wide side of the tool for adjustment ③, turn the keeper nut ① (←) clockwise to loosen the keeper nut.
- (2) Using the narrow side of the tool for adjustment, turn the adjustment hinge pin ② (←) clockwise or (→) counterclockwise to level the refrigerator and freezer door.
- (3) After setting the level of the door, turn the keeper nut (↗) counterclockwise to tighten.

Caution : Do not force too hard to level the height. The hinge pin can be pulled out (Adjustable range of height: Maximum of 2/10 " (5 mm)).

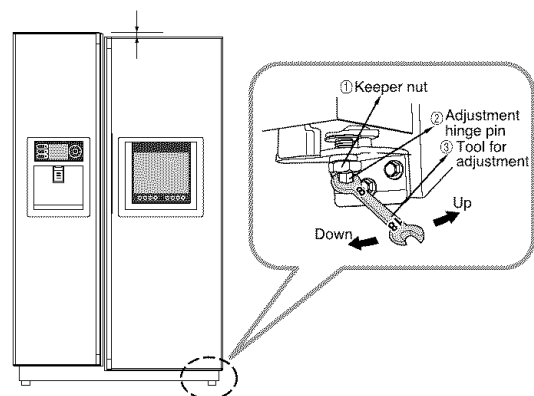

HOW TO INSTALL REFRIGERATOR

2. Filter

Replace the filter when the indicator light comes on or the performance of the icemaker or water dispenser decreases noticeably.

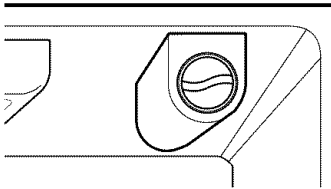

After changing the water filter cartridge, reset the water filter status display and indicator light by pressing and holding the FILTER Button for 3 seconds. (page 13)

1) Remove the old cartridge.

Twist the knob of the cartridge counterclockwise.

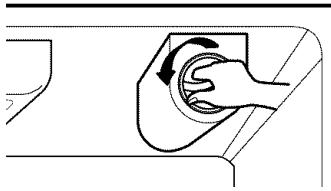

When the cartridge is removed, you will feel it click .

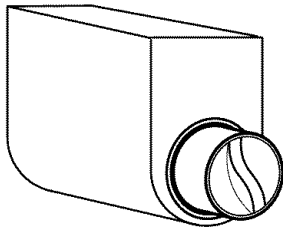

Pull out the cartridge.

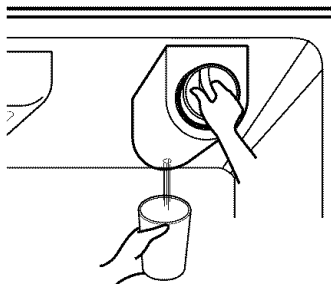

NOTE: There will be some water (25cc) in the filter cartridge. Some spilling may occur. Catch it in a bowl or towel.

2) Replace with a new cartridge.

Take the new cartridge out of its packaging and remove protective cover from the o-rings.

With cartridge knob in the vertical position, push the new filter cartridge into the cover until it stops.

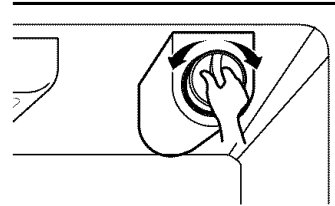

If you can't turn the filter from side to side, it isn't fully inserted. Push it in firmly and twist it into place. You will hear the snap when it clicks into place.

Using the handle, twist the cartridge clockwise about 1/4 turn.

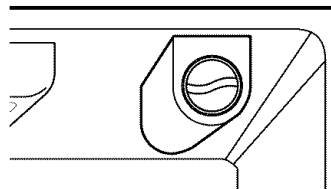
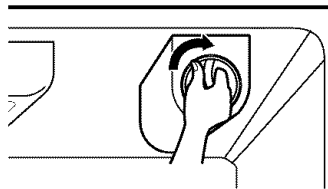

3) Flush the Water System After Replacing Filter

Dispense water through the water dispenser for 3 minutes to purge the system.

There may be a little air in the line, causing noise or hissing. Run the water at the dispenser until the hissing stops to purge the air from the system.

NOTE: - To purchase replacement water filter cartridges, visit your local appliance dealer or part distributor.

- You can also visit our website : www.lgappliances.com or call 1-877-714-7481.

LG MDL	PART NO	MAKER
GR-G277STSA (LSC27990TT)	5231JA2006A	CUNO

HOW TO INSTALL REFRIGERATOR

3. How to Control the Amount of Water Supplied to Icemaker.

3-1. Confirm the amount of water supplied to the icemaker.

1) Confirm the amount of water supplied to the icemaker

(1) Press the button (Figure 1) to select the level of water (Optimum level → Large → Small.)

2) Icemaker Operation Test (Test mode)

(1) Press the button (Figure 1) for more than 3 seconds and It will start the Test mode.

(2) Test the operation of the operating part of the icemaker.

(3) If there is no problem with the operation, water is supplied through the water tube (up to the selected level of water).

(4) The test mode is completed after the water is supplied.

Note : When using the test mode more than twice consecutively, water can overflow.

When the water overflows, wipe the ice storage bin.

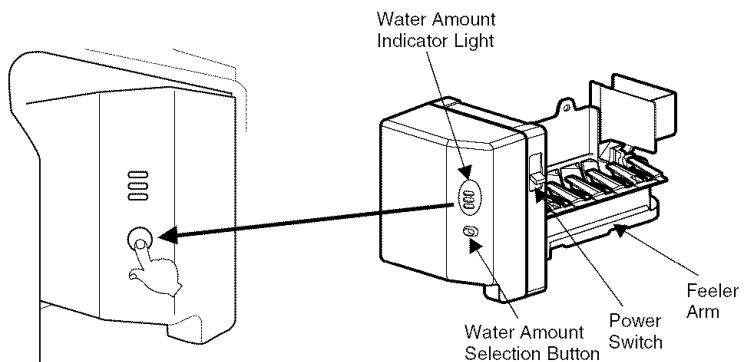
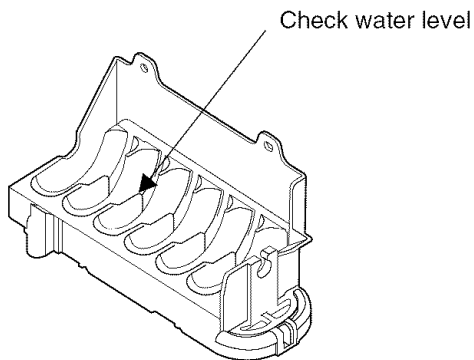
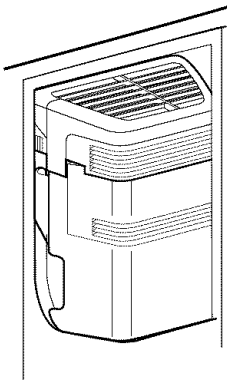

Figure 1.

* It is acceptable if the adjusted level of water is a bit smaller than optimum level.

MICOM FUNCTION

1. Monitor Panel

1-1. GR-G277STSA(LSC27990TT)

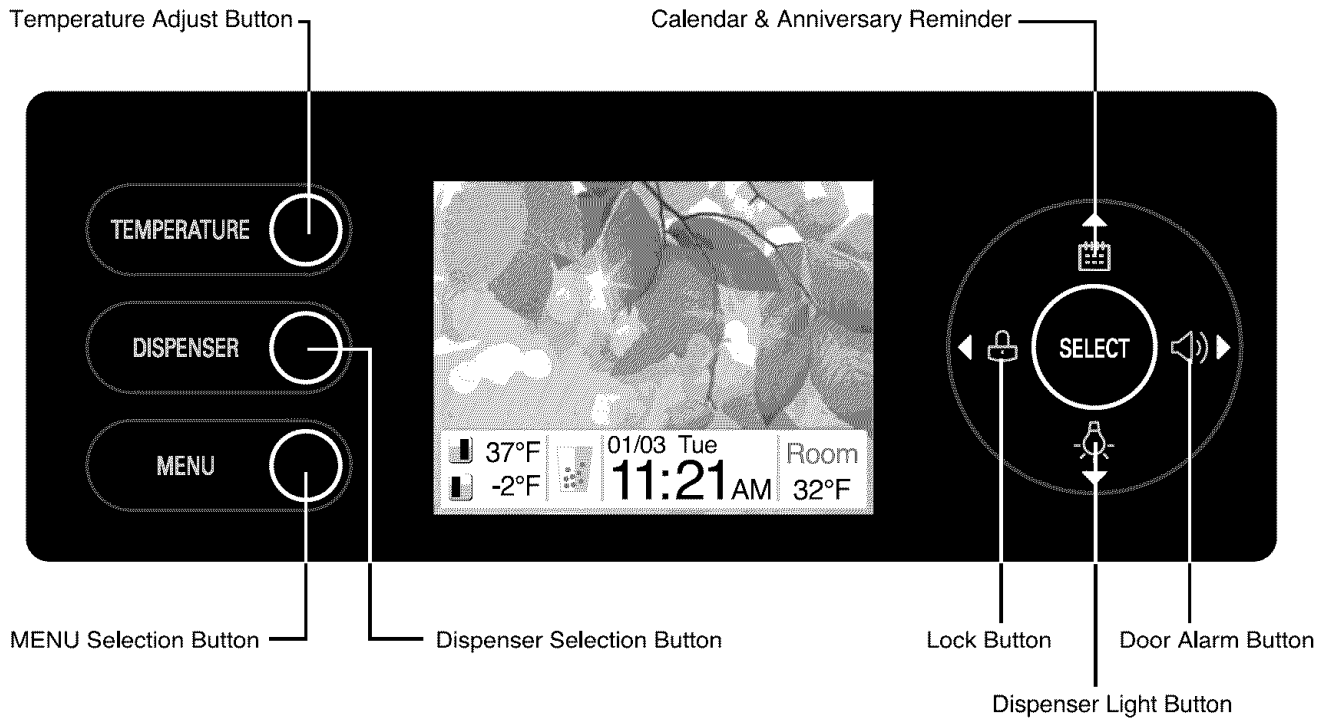

MICOM FUNCTION

1-2. Display Second Function

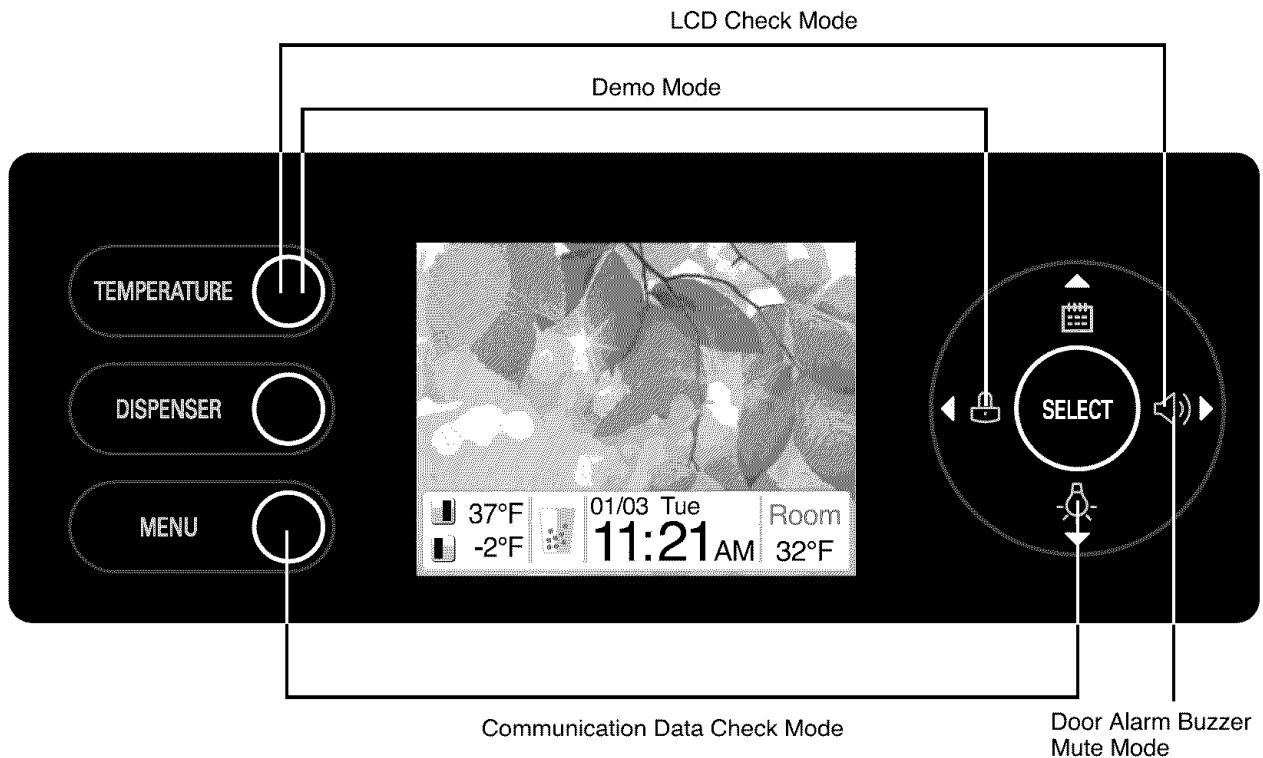

1. Door Alarm Buzzer Mute Mode

Press button to the buzzer on or off.

2. Demo Mode

Demo mode is available for displaying the refrigerator in a sales setting or similar condition. It allows the display, dispenser, lights, and fan to operate without running the compressor.

To enter the DEMO mode, press and hold the **TEMPERATURE** and button simultaneously for 5 seconds until the Ding~ sounds in the lock status.

To exit the DEMO mode and return to normal operation, press and hold the **TEMPERATURE** and button simultaneously for 5 seconds until the Ding~ sounds again in the lock status.

The refrigerator will default to the NORMAL mode (DEMO mode OFF) if the power fails.

2. LCD Check Mode

Press **TEMPERATURE** and button simultaneously for 1 second in the lock status.

4. Communication Data Check Mode

Press **MENU** and button simultaneously for 6 seconds in the lock status.

MICOM FUNCTION

2. Description of Function

2-1-1. Function of Temperature Selection

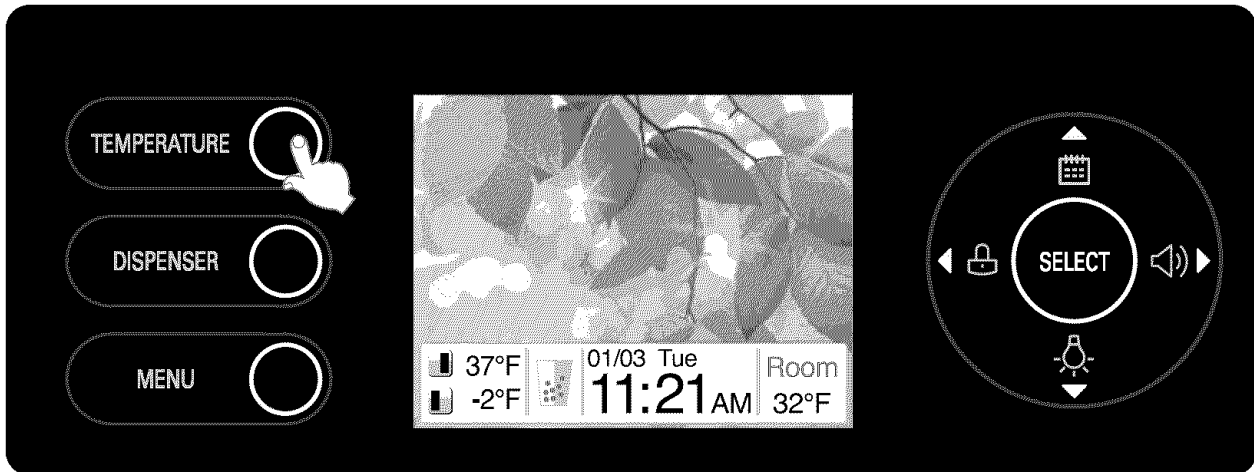

Division	Power Initially On	1st Press	2st Press	3th Press	4th Press
Setting Temperature	● ● ● ● ●	● ● ● ● ●	● ● ● ● ●	● ● ● ● ●	● ● ● ● ●
Temperature Control	COLD	COLDER	COLDEST	COOL	COOLER
Freezer Control	-2 °F	-5 °F	-8 °F	7 °F	1 °F
Refrigeration Control	37 °F	34 °F	32 °F	46 °F	41 °F

* The temperature can vary $\pm 5^{\circ}\text{F}$ ($\pm 3^{\circ}\text{C}$) depending on the load condition.

※ Whenever pressing button, setting is repeated in the order of COLD → COLDER → COLDEST → COOL → COLDER.

- The actual inner temperature varies depending on the food status, as the indicated setting temperature is a target temperature, not actual temperature within refrigerator.
- Refrigeration function is weak in the initial time. Please adjust temperature as above after using refrigerator for minimum 2~3 days.
- Freezer Notch is fixed COLDER unconcerned with display Notch during Icemaking Control Mode and Icemaker Stop switch is selected with ON.

2-1-2. Outside temperature display function

Room
32°F

1. The ambient temperature sensor is located under the upper right hinge cover. This sensor reads the temperature of the room and displays it in the upper right corner of the display.
2. The ambient temperature is displayed between 16 °F and 120 °F. Outside of that range, the display will show Er.
3. Since the ambient temperature sensor is located at the hinge, its reading may differ from other thermometers in the room.

MICOM FUNCTION

2-1-3. Lock function

1. If desiring to lock the display the dispenser and control panel, push on  button more than 3 seconds. Lock icon is appeared at the right of display with lock status.
2. The buzzer sound and control panel and dispenser function is not performed even if pressing display button other than lock key in the lock status.
3. If desiring to release the lock status and pressing the lock button more than 3 seconds. Lock icon is disappeared at the right of display with the lock release status.

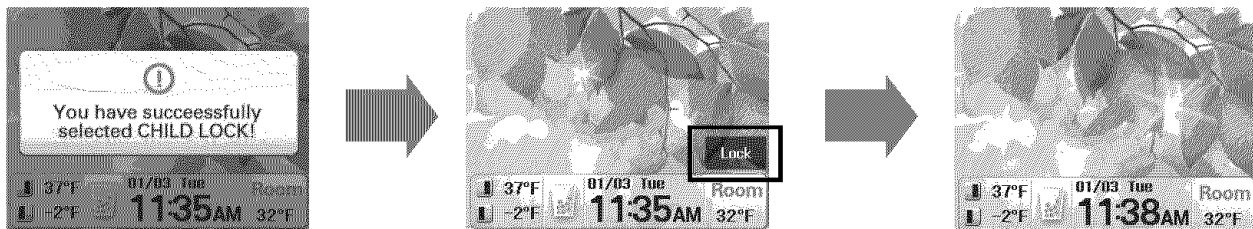
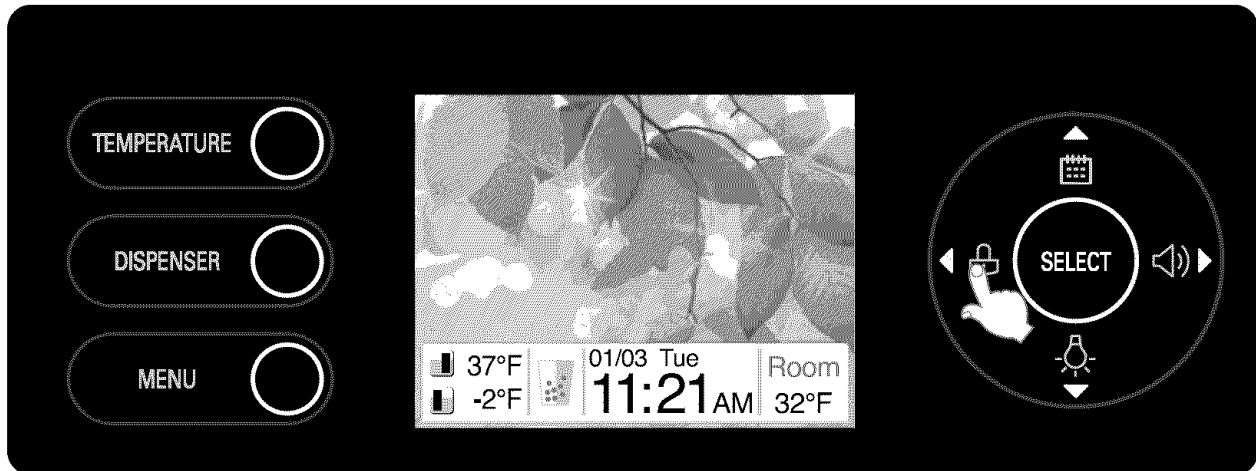

2-1-4. Filter condition display function

1. There is a replacement indicator light for the water filter cartridge on the dispenser.
2. Water filter needs replacement once six months.
3. You will see a reminder pop-up window in the LCD screen 2 weeks before / 1 week before / due date to replace the filter to notify you that the filter needs to be replaced.
4. If you want to reset the filter, use the **Menu** → **Refrigerator** → **Filter Reset** menu.

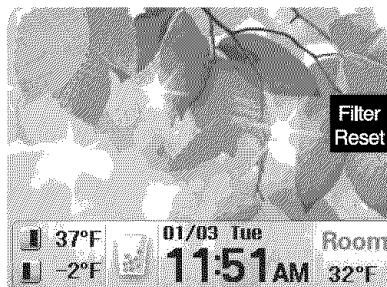

MICOM FUNCTION

2-2. Dispenser use selection

You can select water or ice.

- ※ Select WATER, CRUSHED ICE, or CUBED ICE by pressing the **DISPENSER** button as you desire.
- ※ Use your cup to press lightly on the actuator.
 - Each graphic is indicated for the selected function.
 - You'll hear a CLICK when the ice door closes 5 seconds after ice is dispensed.

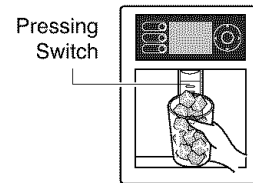
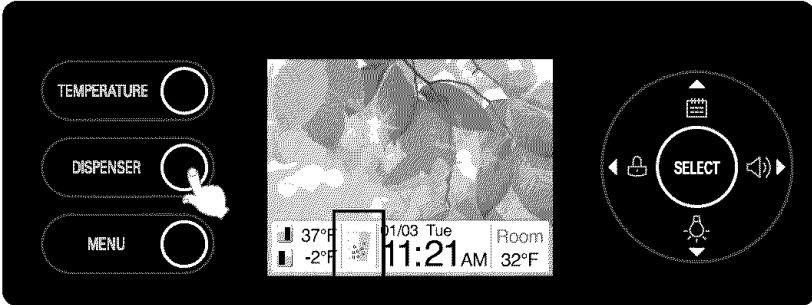

REFERENCE : Hold your cup in the dispenser for a few seconds after dispensing ice or water to catch the last few drops or pieces of ice.

2-3. ICE PLUS Freezing

Select this function to expedite freezing.

- Turn on/off the IcePlus function using the IcePlus button within the Temperature function.
- The "IcePlus" icon remains at the ON status after animation when selecting Special Refrigeration IcePlus FRZ
- ICE PLUS freezer function automatically turns off after a set time.

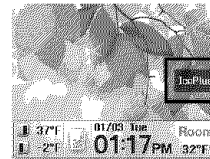
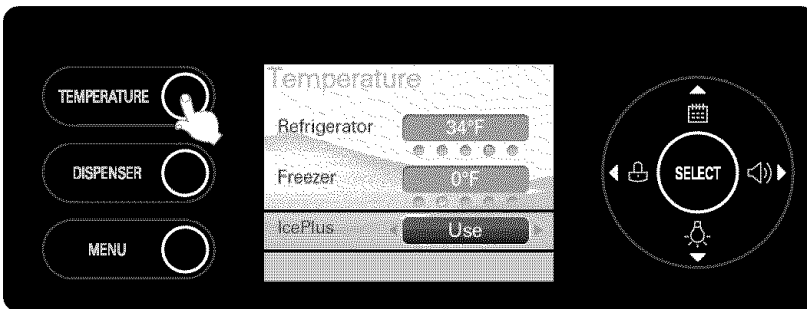

<ON>



<OFF>

2-4. Dispenser Light

- The dispenser light function is repeated following below whenever pressing  button.

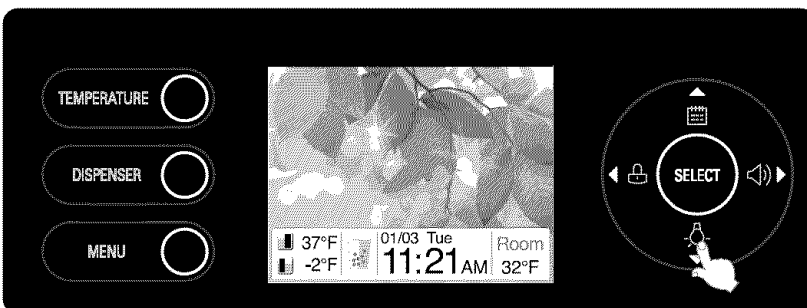

MICOM FUNCTION

2-5. ICE PLUS freezing

1. ICE PLUS freezing is a function to increase the cooling speed of the freezer compartment by running both the compressor and the fan simultaneously.
2. ICE PLUS is cancelled and the refrigerator returns to its default setting in the event of a power interruption.
3. Selecting ICE PLUS changes only the speed of the cooling without affecting the set temperature.
4. The temperature can be adjusted even when ICE PLUS has been selected and is in progress.
5. The freezer operates at whatever temperature was set at the time ICE PLUS was selected.
6. If you select ICE PLUS, the compressor and fan will run until it is deselected or the cycle time has elapsed.
(3 hours : compressor and fan run / 3 ~ 24 hours : COLDEST operation)
7. If a defrost cycle occurs while an ICE PLUS is already running, ICE PLUS runs for its remaining cycle time after the defrost cycle is completed. If the defrost cycle takes longer than 30 minutes, ICE PLUS will run for only 2 hours at the end of the defrost cycle.
8. If you press ICE PLUS during a defrost cycle, the ICE PLUS indicator will illuminate but the compressor will not operate until the defrost cycle is complete.
9. If you press ICE PLUS within 7 minutes of compressor cut-off, the compressor will not operate until the 7-minute delay has passed.
10. The freezer fan motor runs at high speed during the ICE PLUS cycle.

2-6. OptiFresh Function

1. The OptiFresh bin is positioned at the bottom of the refrigerator compartment and has a separate temperature control to allow perfect storage of fruits and vegetables.
2. OptiFresh comprises of OptiFresh sensor at the rear of OptiFresh and a damper between OptiFresh and Freezer compartment and a temperature adjusting display at the top of it.
3. When powered on, the initial NOTCH of OptiFresh display will be on OptiFresh Crisper.
If only the refrigerator door is opened, the OptiFresh LED will be ON.
4. The OptiFresh sensor opens and closes the damper based on the temperature.
5. The OptiFresh damper will cycle every hour to prevent icing up.

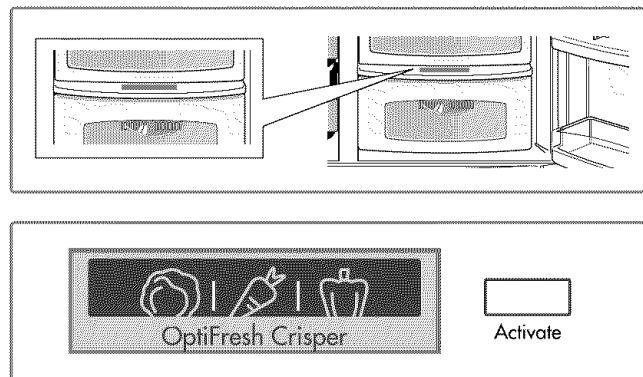

- Press the button to toggle between ON and OFF.

MICOM FUNCTION

2-7. Control of variable type freezing fan

1. To increase cooling speed and response to load, the MICOM will vary the speed of the freezer fan between low and high.
2. The MICOM runs the fan at high speed only at power-up and for ICE PLUS cycles, and runs at low speed for all other settings.
3. If you open the freezer door, the refrigerator door, or the home bar door, and the freezer fan was running at high speed, it will reduce to low speed. If it was running at low speed when a door was opened, it will turn off.
4. If the MICOM determines the BLDC fan motor is locked up, (no signal for 115 seconds) it will show a failure code on the display and cut power to the fan. To power the fan again, unplug the refrigerator for a few seconds and plug it in again.

2-8. Control of cooling fan motor

1. The cooling fan motor performs ON/OFF control by linking with the COMPRESSOR.
2. It controls at the single RPM without varying RPM.
3. Failure sensing method is same as in fan motor of freezing fan motor (refer to failure diagnosis function table for failure display).

2-9. Door opening alarm

1. The buzzer sounds when any door is held open for more than one minute.
2. After any door has been open for one minute, the buzzer sounds three times for $\frac{1}{2}$ second each, then it sounds three times for $\frac{1}{2}$ second each every thirty seconds until the door is closed.
3. When all open doors have been closed, the buzzer stops.

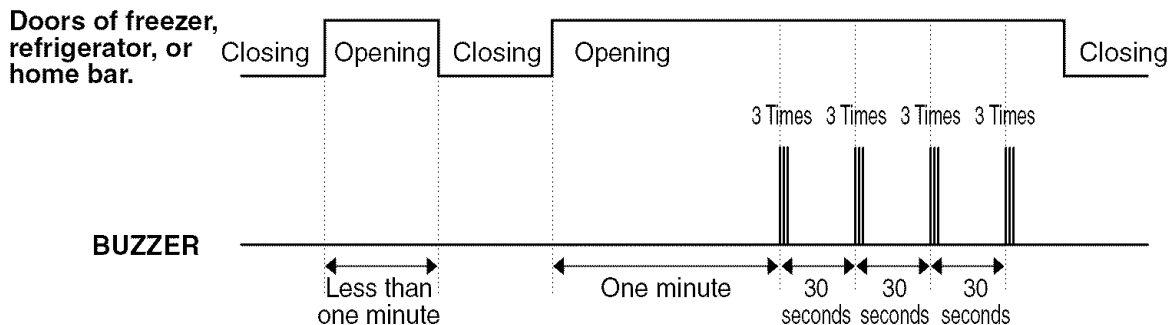

2-10. Ringing of button selection buzzer

1. If pressing the front display button, Ding ~ sound rings.

MICOM FUNCTION

2-11. Ringing of manual operation, manual frost defrost buzzer

1. The buzzer sounds briefly when the test button on the main PCB is pressed.
2. If you select manual operation, the buzzer sounds three times for $\frac{2}{10}$ second each, then it sounds three times for $\frac{2}{10}$ second each every thirty seconds until the door is closed.
3. If you select manual defrost, the buzzer sounds three times for $\frac{2}{10}$ second each, then it sounds three times for $\frac{2}{10}$ second each every thirty seconds until the door is closed.

2-12. Defrost function

1. Defrost is cycled whenever the compressor's runtime reaches $7 \sim 7 \frac{1}{2}$ hours.
2. In providing initial power (or returning power failure), defrost starts whenever total operation time of compressor becomes $4 \sim 4 \frac{1}{2}$ hour.
3. Defrost is completed if temperature of a frost removal sensor becomes more than 5°C after starting frost removal. Poor frost removal is not displaced if it does not arrive at 5°C even if two hours have passed after starting frost removal.
4. No defrost cycle is run if the defrost sensor fails.

2-13. Refrigerator room lamp automatic off

- Refrigerator room lamp turn on and off by refrigerator door switch.
- If refrigerator room lamp continuously turns on more than 7 minutes, the refrigerator room lamp turns off automatically.

MICOM FUNCTION

2-14. Sequential operation of components

Component products such as compressor, frost removal heater, freezing room fan, cooling fan, and step motor damper are sequentially operated as follows for preventing noise and part damage occurred due to simultaneous operation of many parts in applying initial power and completing test.

Function	Load Operation Sequence	Remark
In applying Initial power	<p>When temperature of a frost removal sensor becomes more than 45°C (At purchase, shipping)</p>	<p>If error occurs during operation, initial operation is not done.</p> <p>■ Sequence of load operation when closing FREEZER and REFRIGERATOR.</p>
	<p>When temperature of a frost removal sensor becomes less than 45°C (In power failure, service)</p>	
TEST MODE	<p>Test mode 1 (Manual function)</p>	<p>If you press the switch in the again test mode 2 or temperature of a frost removal sensor is more than 5°C, it immediately returns to the test mode for initial operation (COMPRESSOR operates after 7 minutes).</p>
	<p>Test mode 2 (Manual frost removal)</p>	

MICOM FUNCTION

2-15. Failure Diagnosis Function

1. Failure diagnosis facilitates service when a failure code shows during product operation.
2. When a failure is detected, the buttons are deactivated.
3. If a failure code is released, the MICOM resets and normal operation continues.
4. The failure code is displayed on the display screen. All display graphics that are not part of the failure code are turned off

(1) GR-G277STSA(LSC27990TT)

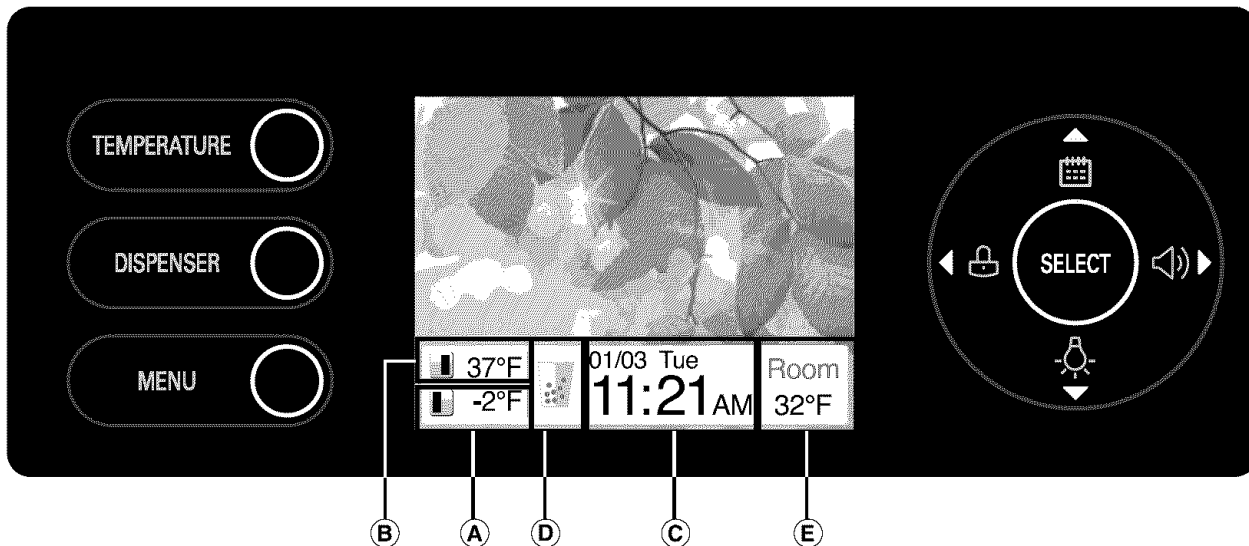

○ : PROPER OPERATION

NO	ITEM	FAILURE CODE INDICATION PART		CONTENTS OF FAILURE	PRODUCT OPERATION STATUS IN FAILURE				
		FREEZER ROOM NOTCH TEMPERATURE DISPLAY	REFRIGERATOR ROOM NOTCH TEMPERATURE DISPLAY		COMPRESSOR	FREEZING BLDC MOTOR	COOLING BLDC MOTOR	DEFROST HEATER	STEPPING MOTOR DAMPTER
1	ABNORMAL FREEZER SENSOR	Er	FS	FREEZER SENSOR SHORT CIRCUIT	ON FOR 15 MINUTES / OFF FOR 15 MINUTES	STANDARD RPM	○	○	○
2	ABNORMAL REFRIGERATOR SENSOR1(R1) (UPPER PART IN THE REFRIGERATOR COMPARTMENT)	Er	rS	REFRIGERATOR SENSOR 1 SHORT CIRCUIT	○	STANDARD RPM	○	○	FULL OPENING FOR 10 MINUTES/ FULL CLOSING FOR 15 MINUTES
3	ABNORMAL REFRIGERATOR SENSOR2(R2) (LOWER PART IN THE REFRIGERATOR COMPARTMENT)	NORMAL DISPLAY (NOTE 2)(See page 19)		REFRIGERATOR SENSOR 2 SHORT CIRCUIT	○	STANDARD RPM	○	○	○
4	ABNORMAL DEFROST SENSOR	Er	dS	ABNORMAL SHORT CIRCUIT	○	STANDARD RPM	○	NO DEFROST	○
5	FAILED DEFROSTING	Er	dH	DEFROST HEATER, TEMPERATURE FUSE SHORT CIRCUIT, UNPLUGGED CONNECTOR(INDICATED 4 HOUR LATER AFTER TROUBLE)	○	STANDARD RPM	○	○	○
6	ABNORMAL FREEZING BLDC MOTOR	Er	FF	MOTOR DEFECT, HOOKED OF LEAD WIRE TO FAN, CONTACT OF STRUCTURES WITH FAN, SHORT OR OPEN OF LEAD WIRE(THERE IS NO SIGNAL OF BLDC MOTOR MORE THAN 115 SECONDS IN OPERATION OF FAN MOTOR)	○	OFF	○	○	○
7	ABNORMAL COOLING BLDC MOTOR	Er	CF		○	STANDARD RPM	OFF	○	○
8	ABNORMAL COMMUNICATION	Er	CO	SHORT OR OPEN OF LEAD WIRE CONNECTING BETWEEN MAIN PCB AND DISPLAY PCB, TRANSMISSION TR AND RECEIVING PART	○	STANDARD RPM	○	○	○
9	ABNORMAL AMBIENT SENSOR	NORMAL DISPLAY (NOTE 1)(See page 19)		AMBIENT SENSOR SHORT CIRCUIT	○	○	○	○	○
10	ABNORMAL WATER TANK SENSOR	NORMAL DISPLAY (NOTE 2)(See page 19)		WATER TANK SENSOR SHORT CIRCUIT	○	○	○	○	○
11	ABNORMAL OPTICHELL SENSOR	NORMAL DISPLAY (NOTE 2)(See page 19)		OPTICHELL SENSOR SHORT CIRCUIT	○	○	○	○	○













MICOM FUNCTION

※ ALL DISPLAY PARTS TURN OFF OTHER THAN FREEZER ROOM NOTCH TEMPERATURE DISPLAY AND REFRIGERATOR ROOM NOTCH TEMPERATURE DISPLAY (FAILURE CODE INDICATION PART) IN CASE OF INDICATING FAILURE MODES (EXCEPT FOR NOTE1, NOTE2)

NOTE1) FREEZER ROOM NOTCH TEMPERATURE DISPLAY AND REFRIGERATOR ROOM NOTCH TEMPERATURE DISPLAY (FAILURE CODE INDICATION PART) ARE NORMALLY INDICATED IN ABNORMAL AMBIENT SENSOR, AND "Er" INDICATED ON THE AMBIENT TEMPERATURE DISPLAY (EXCEPT FOR THE AMBIENT TEMPERATURE DISPLAY, OTHER DISPLAY PARTS ARE INDICATED NORMALLY)

NOTE 2) R2-SENSOR, WATER-TANK SENSOR AND OPTIC HILL SENSOR IS NOT INDICATED ON THE FAILURE INDICATING PART BUT INDICATED IN CHECKING ALL DISPLAY PARTS

(WHEN PRESSING THE TEMPERATURE AND  BUTTON IN THE LOCK STATUS FOR MORE THAN 1 SECOND).

<ul style="list-style-type: none"> — R2-SENSOR (MIDDLE ROOM) — WATER-TANK SENSOR — OPTI-FRESH SENSOR 	<input type="checkbox"/> N O R M A L : DISPLAY PART GRAPHIC ON THE  PART TURNS ON <input type="checkbox"/> A B N O R M A L : DISPLAY PART GRAPHIC ON THE  PART TURNS OFF	<div style="border-left: 1px solid black; border-right: 1px solid black; border-top: 1px solid black; border-bottom: 1px solid black; padding: 0 10px;"> THE OTHER DISPLAY GRAPHICS TURN ON </div>
	<input type="checkbox"/> N O R M A L : DISPLAY PART GRAPHIC ON THE  PART TURNS ON <input type="checkbox"/> A B N O R M A L : DISPLAY PART GRAPHIC ON THE  PART TURNS OFF	
	<input type="checkbox"/> N O R M A L : DISPLAY PART GRAPHIC ON THE  PART TURNS ON <input type="checkbox"/> A B N O R M A L : DISPLAY PART GRAPHIC ON THE  PART TURNS OFF	
	<input type="checkbox"/> N O R M A L : DISPLAY PART GRAPHIC ON THE  PART TURNS ON <input type="checkbox"/> A B N O R M A L : DISPLAY PART GRAPHIC ON THE  PART TURNS OFF	
	<input type="checkbox"/> N O R M A L : DISPLAY PART GRAPHIC ON THE  PART TURNS ON <input type="checkbox"/> A B N O R M A L : DISPLAY PART GRAPHIC ON THE  PART TURNS OFF	
	<input type="checkbox"/> N O R M A L : DISPLAY PART GRAPHIC ON THE  PART TURNS ON <input type="checkbox"/> A B N O R M A L : DISPLAY PART GRAPHIC ON THE  PART TURNS OFF	

(2) TEST FUNCTION

TEST KEY EXISTS ON PWB ASSY, MAIN BOARD.

MODE	OPERATION	CONTENTS	REMARKS
TEST1	PRESS TEST BUTTON ONCE <STRONG COLD MODE>	1. CONTINUOUS OPERATION OF COMPRESSOR 2. CONTINUOUS OPERATION OF FREEZING BLDC MOTOR (HIGH-SPEED RPM) AND COOLING BLDC MOTOR 3. DEFROST HEATER TURNS OFF 4. MAIN STEPPING MOTOR DAMPER IS COMPLETELY OPENED (OPEN OF BAFFLE) 5. ALL DISPLAY GRAPHICS TURNS ON	FREEZING FAN TURNS OFF IN DOOR OPENING
TEST2	PRESS TEST BUTON ONCE AT THE TEST MODE 1 STATUS <FORCED DEFROST MODE>	1. COMPRESSOR OFF 2. FREEZING BLDC MOTOR AND COOLING BLDC MOTOR TURN OFF 3. DEFROST HEATER TURNS ON 4. MAIN STEPPING MOTOR DAMPER IS COMPLETELY CLOSED (CLOSING OF BAFFLE) 5. ALL DISPLAY GRAPHICS TURNS OFF (ONLY "FAILURE CODE INDICATION PART" TURNS ON FOR "22" STATUS)	RETURN TO THE NORMAL MODE WHEN THE DEFROST SENSOR IS ABOVE +5°C
NORMAL STATUS	PRESS TEST BUTON ONCE AT THE TEST MODE 2 STATUS	RETRUING TO INITIAL STATUS	COMPERSOR WILL OPERATE AFTER DELAY FOR 7 MINUTES

※ LCD check function: If simultaneously pressing **TEMPERATURE** and  button for a second in the lock status, a back light is turned on and all display LCD graphics on. If releasing the button, the LCD graphic displays the previous status.

MICOM FUNCTION

2-16. Test Function

1. The test function assists in diagnosing the PWB and determining the exact mode of failure.
2. The test button is on the main PCB. When test mode is engaged, it will complete its test cycle and default to normal operation within 2 hours.
3. The buttons are disabled while the test mode is in effect.
4. When you have finished running test mode, unplug the refrigerator to reset it to normal operation.
5. If a failure is detected during test mode, release the test mode to display the failure code.
6. If a failure code is displayed, the test mode cannot be started.

Mode	Operation	Contents	Remarks
Test 1	Press test button once (strong cold mode)	<ol style="list-style-type: none"> 1. Continuous operation of compressor 2. Continuous operation of freezing BLDC motor (high-speed RPM) and cooling BLDC motor 3. Defrost heater turns off 4. Stepping motor damper is completely opened (baffle is closed) 5. OptiFresh stepping motor damper is completely closed. 6. All display LCD graphics turn on. 	Freezer fan turns off when door is opened.
Test 2	Press test button once at the test mode 1 status (forced defrost mode)	<ol style="list-style-type: none"> 1. Compressor OFF 2. Freezing BLDC motor and cooling BLDC motor turn off 3. Defrost heater turns on 4. Stepping motor damper is completely closed (baffle is closed) 5. OptiFresh stepping motor damper is completely closed. 	Return to the normal mode when the defrost sensor is above +5°C (+41°F)
Normal Status	Press test button once at the test mode 2 status	Return to the initial status.	Compressor will operate after delay for 7 minutes

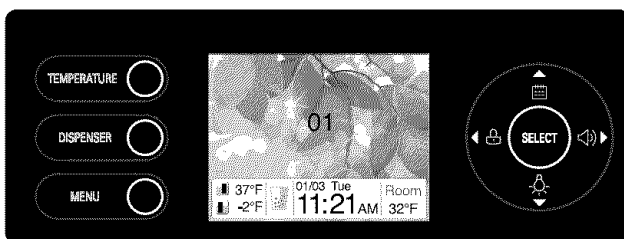

<TEST MODE 1>

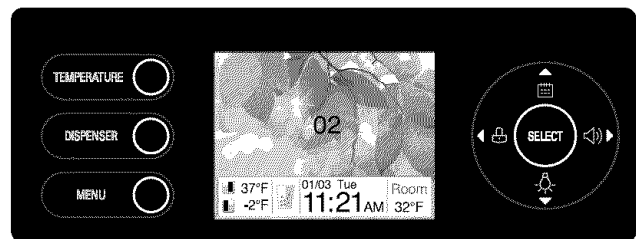

<TEST MODE 2>

MICOM FUNCTION

2-17. Dispenser Function

1. The dispenser allows serving ice and water without opening the door.
2. Pressing the dispenser switch dispenses crushed or cubed ice or water. If ice is selected, the switch operates the door solenoid also. The door will close 5 seconds after the ice is dispensed.
3. If the freezer door is opened, the dispenser is deactivated.
4. If there is no OFF signal 3 minutes after the ice dispenser is activated, the auger and door solenoid are turned off. The auger will stop immediately, but the door will not close for another 5 seconds.
5. The dispenser lamp turns on automatically if the crushed/cubed/water button is pressed or if the dispenser button is pressed. It will turn off automatically shortly thereafter.
6. Selection function of water/crushed/cube ice
 - 1) Select crushed/cubed/water. The display will show your selection.
 - 2) If you select cubed ice, the auger is rotated to dispense cubes.
 - 3) If you select crushed ice, the auger is rotated in the opposite direction to direct the cubes through the crusher.
7. Water dispenser function
 - 1) If you select water, the display will indicate water.
 - 2) The water dispenser uses a solenoid connected directly to the water pipe. Pressing the dispenser switch operates the solenoid, which is at the right side of the back plate.

EXPLANATION FOR MICOM CIRCUIT

1. Explanation for PWB circuit

1-1. Power circuit

The power circuit includes a Switched Mode Power Supply (SMPS). It consists of a rectifier (BD1 and CE1) converting AC to DC, a switch (IC2) switching the DC voltage, a transformer, and a feedback circuit (IC3 and IC4).

Caution : Since high voltage (160 Vdc) is maintained at the power terminal, wait at least 3 minutes after unplugging the appliance to check the voltages to allow the current to dissipate.

Voltage of every part is as follows:

Part	VA1	CE1	CE2	CE3	CE4	CE5
Voltage	120 Vac	160 Vdc	14 Vdc	12 Vdc	15.5 Vdc	5 Vdc

(1) GR-G277STSA(LSC27990TT)

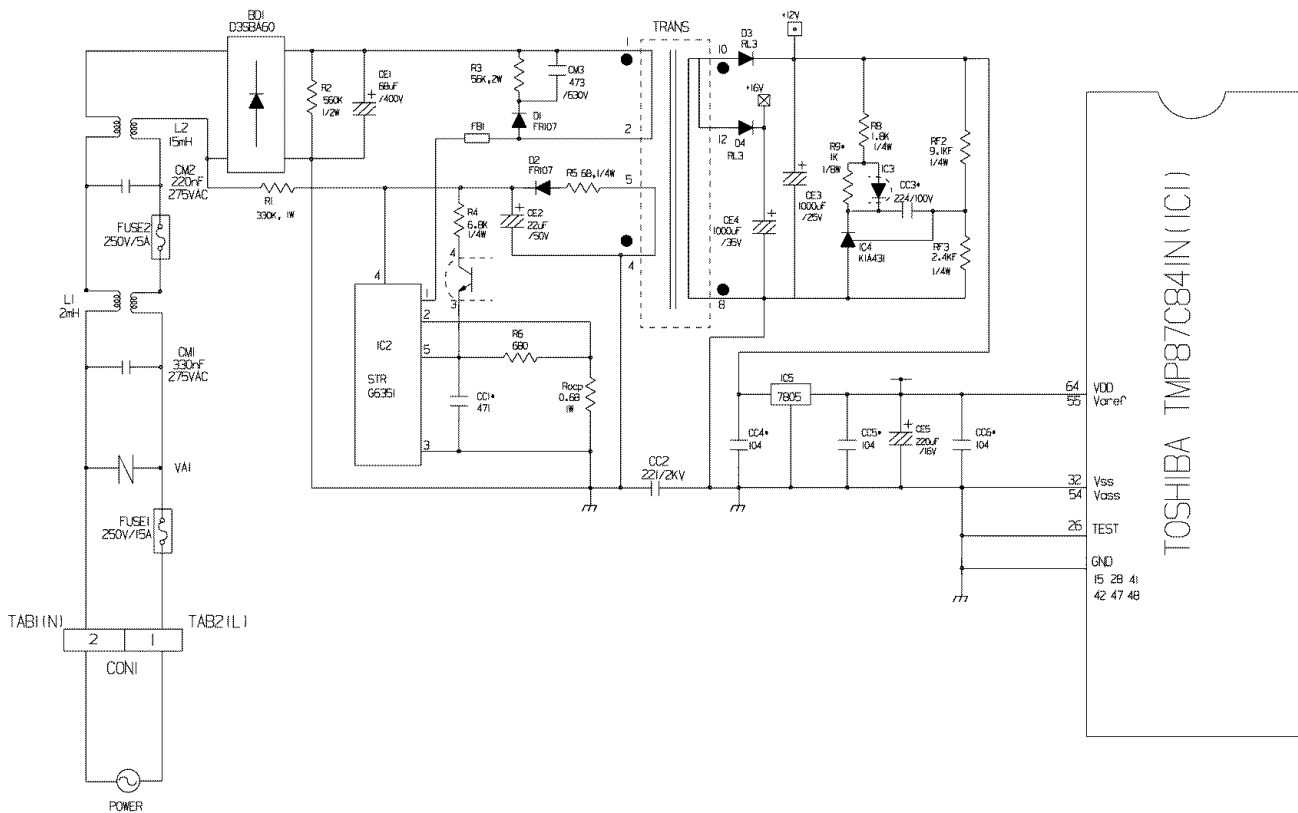

EXPLANATION FOR MICOM CIRCUIT

1-2. Oscillation circuit

The oscillation circuit generates a basic clock signal for synchronization and time calculation related to the transmission of data and calculations made by the MICOM (IC1). The oscillator (OSC1) must always be replaced with an exact replacement part. If this specification is changed, the change will affect the time calculations of the MICOM and it might not work at all.

(1) GR-G277STSA(LSC27990TT)

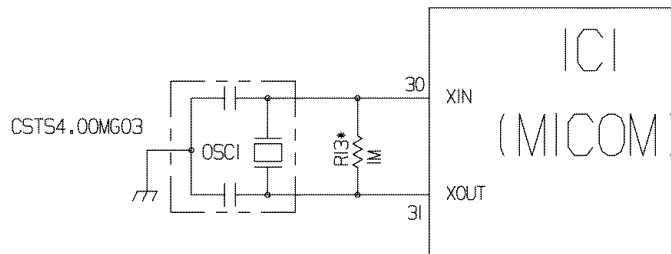

1-3. Reset circuit

The RESET circuit allows various parts of the MICOM, such as RAM, defrosting, etc., to be restarted from the initial state when power is interrupted or restored. A LOW signal applied to the reset terminal for 10 ms causes the MICOM to reset itself. During normal operation, the voltage at the reset terminal is 5 Vdc. If the reset fails, the MICOM will not operate.

(1) GR-G277STSA(LSC27990TT)

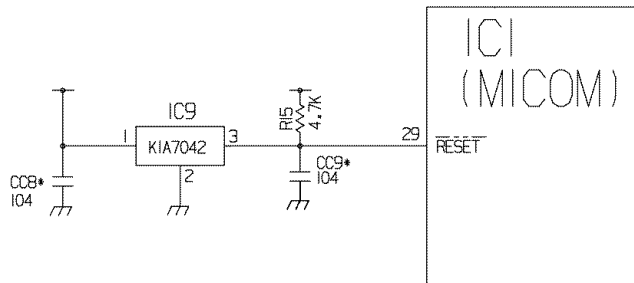

EXPLANATION FOR MICOM CIRCUIT

1-4. Load/dispenser operation, door opening circuit

1. LOAD DRIVING CIRCUIT

- * The fan operates at the regular speed even if the door of the refrigerator or freezer is opened. When the doors are closed, the fan reverts to its original speed.
- * (A), (B), (C), and (D) of door switch for the freezer or refrigerator are connected to the door open sensing circuit in parallel toward both ends of switch to determine door open at MICOM.
- * In the TEST mode, the fan will stop if any door is opened. It will resume operation when the door is closed.

Type of Load	Compressor	Defrost Heater	AC Converting Relay	Refrigerator LAMP	Dispenser Heater
Measuring part (IC6)	IC6-16	IC6-13	IC6-12	IC6-15	IC6-14
Status	ON	Within 1 V			
	OFF	12 V			

(1) GR-G277STSA(LSC27990TT)

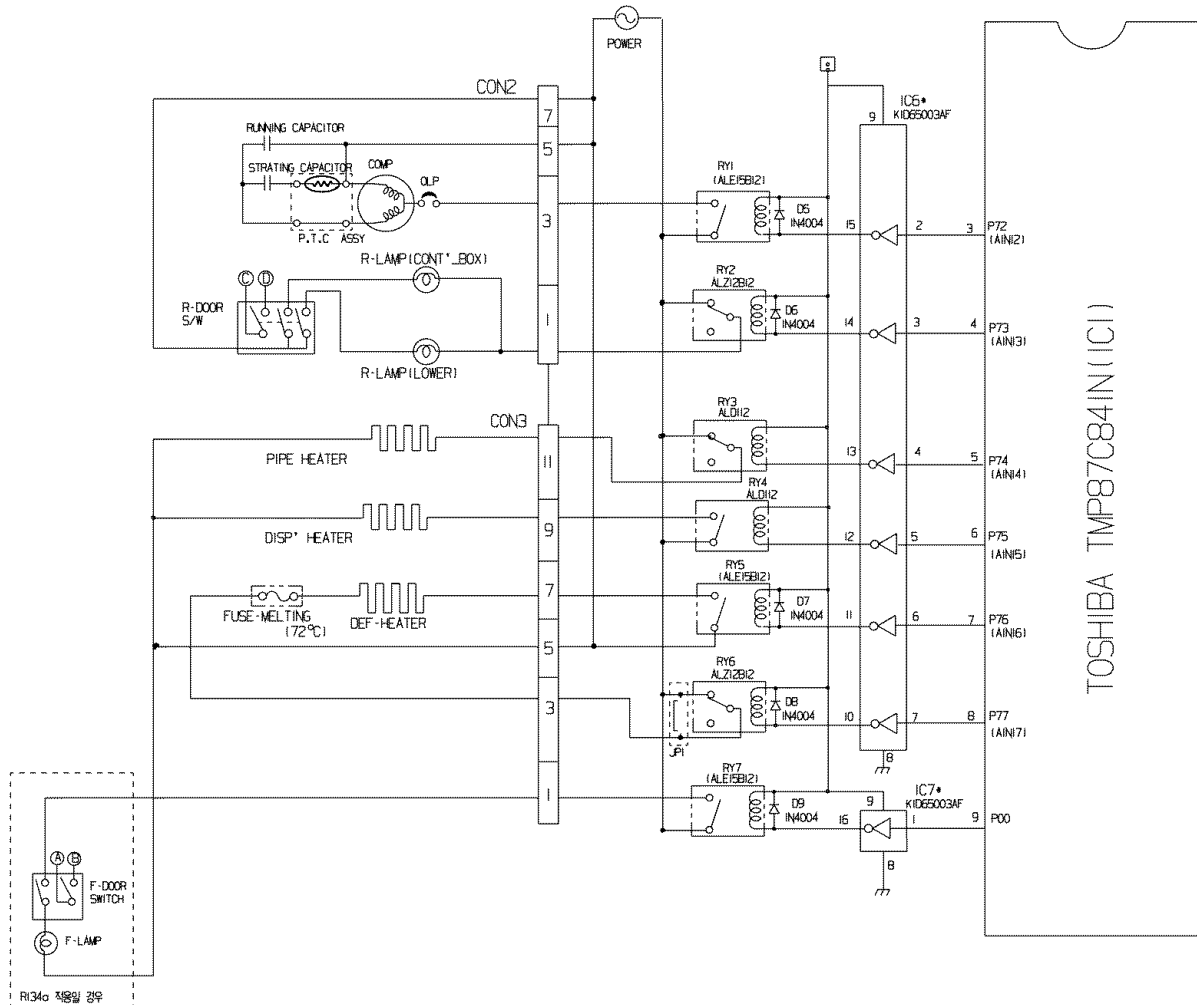

EXPLANATION FOR MICOM CIRCUIT

1-5. Dispenser operation circuit

(1) GR-G277STSA(LSC27990TT)

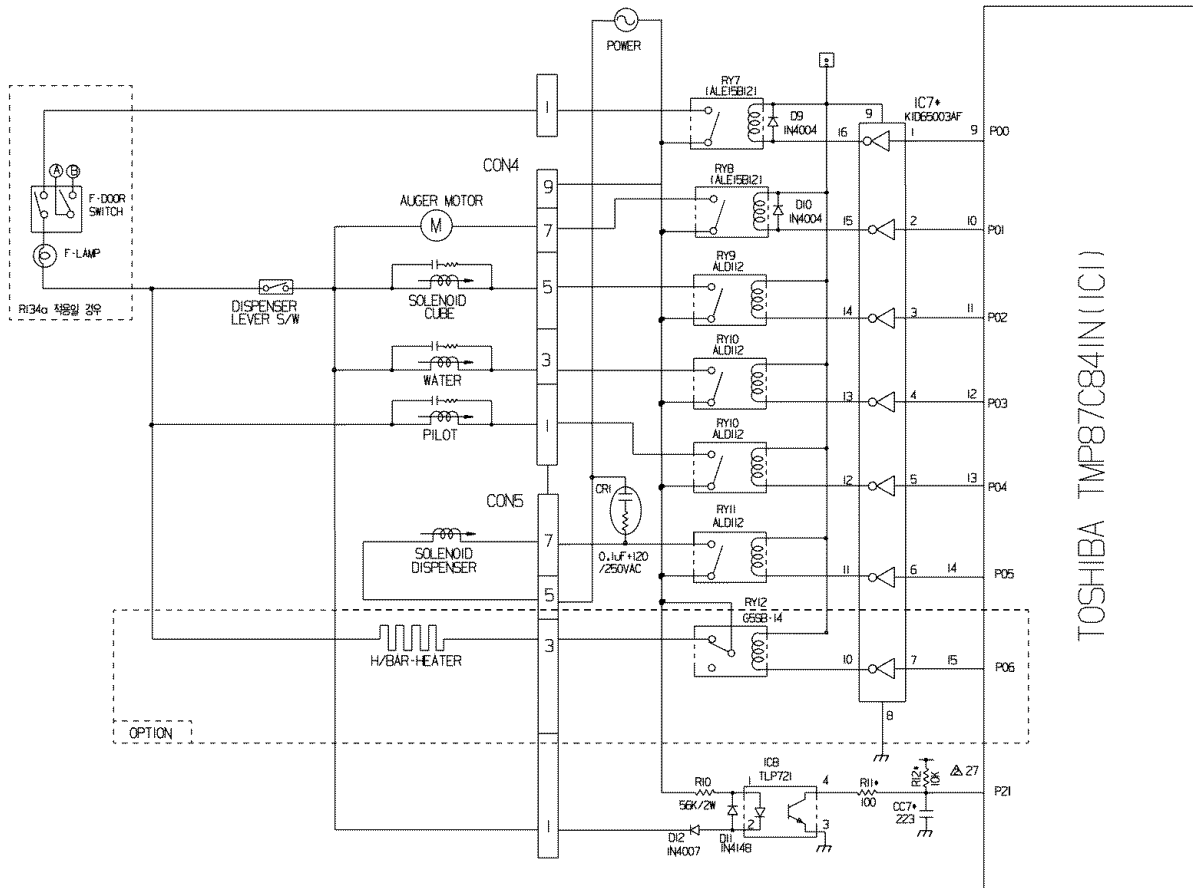

1) Check load driving status

Type of Load	GEARED MOTOR	SOLENOID CUBE	WATER VALVE	PILOT VALVE	SOLENOID DISPENSER
			WATER		
Measuring part	IC7-15	IC7-14	IC7-13	IC7-12	IC7-11
Status	ON	Within 1 V			
	OFF	12 V			

2) Lever Switch sensing circuit

Measuring part	IC1(Micom) (No. 16)
Lever S/W	
On	<p>5 V 0 V (60 Hz)</p>
OFF	5V

EXPLANATION FOR MICOM CIRCUIT

1-6. Door opening sensing circuit

(1) GR-G277STSA(LSC27990TT)

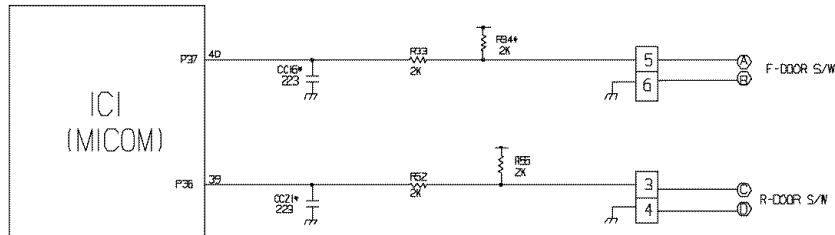

Measuring part	IC1 (MICOM) No. (44, 45) / (45, 46) / (47, 48) Pin
Door of Freezer and Refrigerator	
Closing	5 V (A) - (B), (C) - (D) . Switch at both ends are at Off status)
Opening	0 V (A) - (B), (C) - (D) . Switch at both ends are at On status)

* Since door switches (A) and (B) are interconnected, if either fails, the other will not respond properly.

* If either switch fails, the light will not come on.

EXPLANATION FOR MICOM CIRCUIT

1-7. Temperature sensing circuit

(1) GR-G277STSA(LSC27990TT)

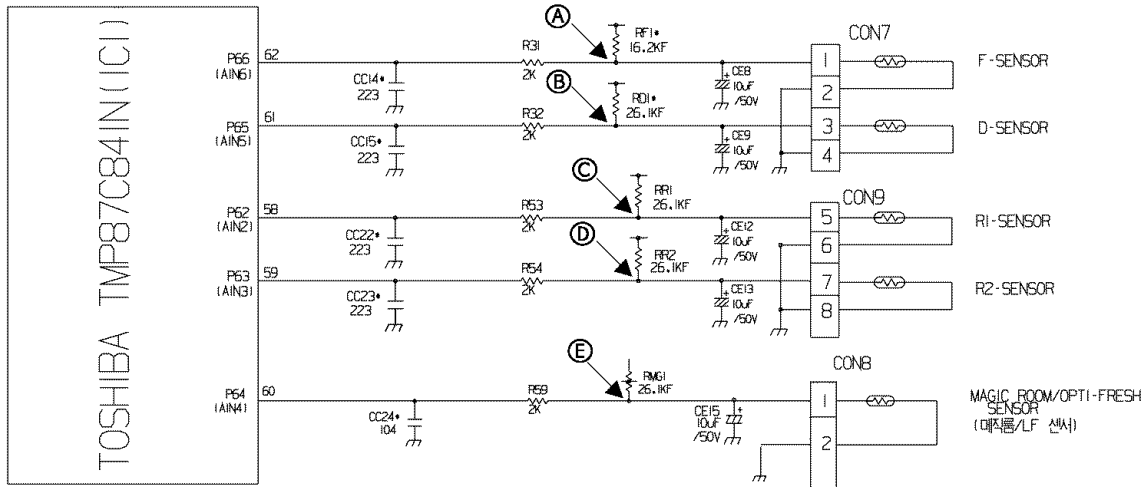

The circuits involving the freezer and refrigerator sensors control the temperature in both the freezer and the refrigerator. The icemaker sensor detects when ice is made. The defrost sensor determines both the need for defrosting and the efficiency of the defrost operation. See the table below for voltages and checkpoints.

SENSOR	CHECK POINT	NORMAL(-22 °F ~ 122 °F)	IN SHORT	IN OPEN
Freezing sensor	POINT (A) Voltage	0.5 V ~ 4.5 V	0 V	5 V
Defrost sensor	POINT (B) Voltage			
Refrigerator sensor 1	POINT (C) Voltage			
Refrigerator sensor 2	POINT (D) Voltage			
Magic room/ Opti Fresh Sensor	POINT (E) Voltage			

EXPLANATION FOR MICOM CIRCUIT

1-8. Switch entry circuit

The following circuits are sensing signal form the damper motor reed switch for testing and diagnosing the refrigerator.

(1) GR-G277STSA(LSC27990TT)

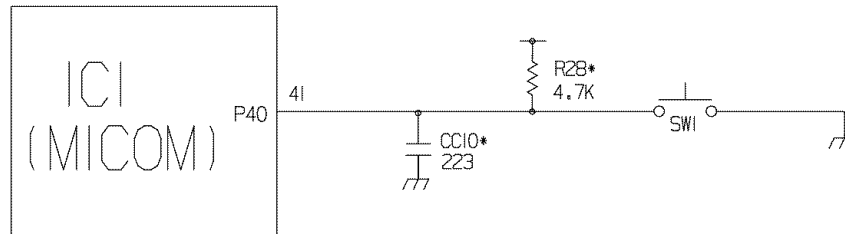

1-9. Option designation circuit (model separation function)

(1) GR-G277STSA(LSC27990TT)

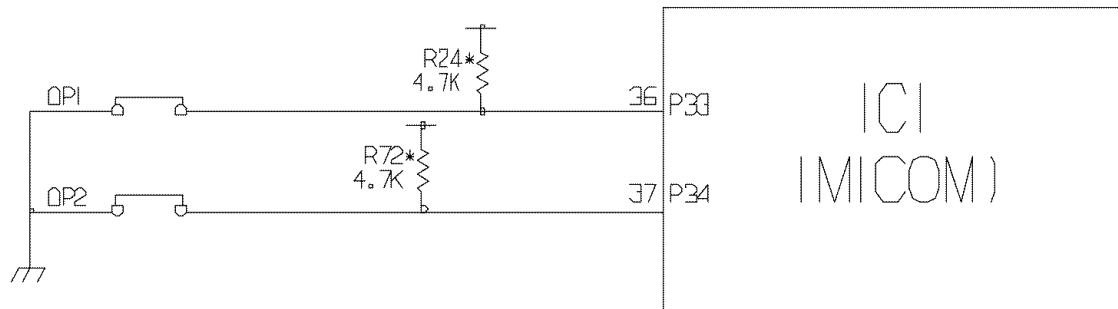

The circuits shown above vary according to which features are included on your particular model.

Separation	Connection Status	Application Standard
OP1	Connection	OptiFresh exist
	OUT	OptiFresh don't exist

▶These circuits are preset at the factory and cannot be altered.

EXPLANATION FOR MICOM CIRCUIT

1-10. Stepping motor operation circuit

(1) GR-G277STSA(LSC27990TT)

The motor is driven by magnetism formed in the areas of the coils and the stator. Rotation begins when a HIGH signal is

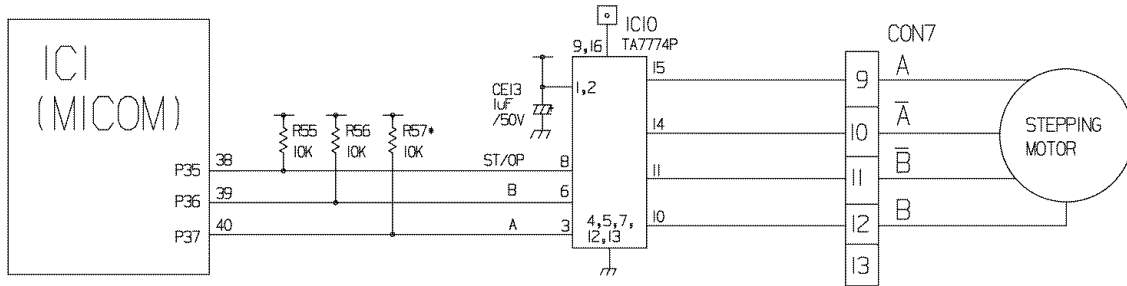

applied to MICOM Pin 33 of IC10 (TA7774F). This causes an output of HIGH and LOW signals on MICOM pins 34 and 35.

Explanation) The stepping motor is driven by sending signals of 3.33 mSEC via MICOM pins 33, 34, and 35, as shown in the chart below. These signals are output via terminals 10, 11, 14, and 15 via input terminals 3, 6, and 8 of IC10 (TA7774F), the motor drive chip. The output signals allow the coils wound on each phase of the stator to form a magnetic field, which causes rotation. Input to the terminals INA and INB of IC10 as shown in the chart below drives the motor.

CCW (Reverse rotation) ← ————— → (Positive rotation) CW

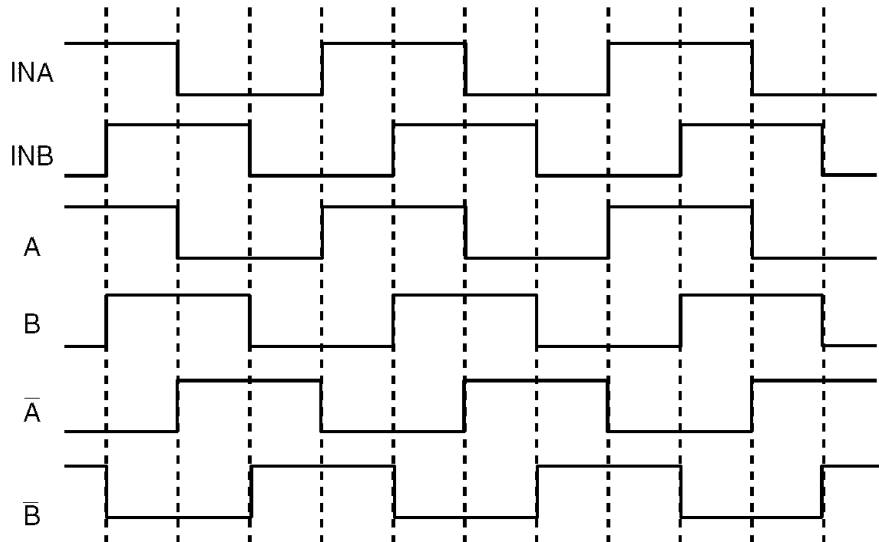

EXPLANATION FOR MICOM CIRCUIT

1-11. Fan motor driving circuit (freezer, mechanical area)

1. The circuit cuts all power to the fan drive IC, resulting in a standby mode.
2. This circuit changes the speed of the fan motor by varying the DC voltage between 7.5 Vdc and 16 Vdc.
3. This circuit stops the fan motor by cutting off power to the fan when it senses a lock-up condition.

	Ⓐ, Ⓓ part	Ⓑ part	Ⓔ part
Motor OFF	5V	2V or less	2V or less
Motor ON	2 ~ 3V	12 ~ 14V	8 ~ 16V

(1) GR-G277STSA(LSC27990TT)

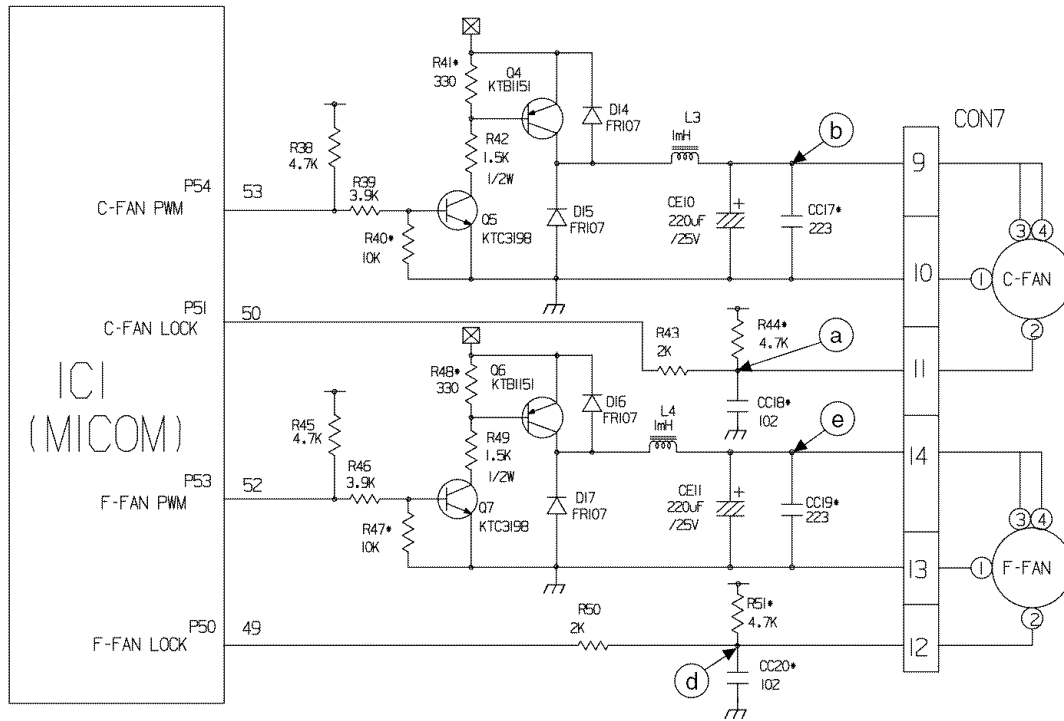

EXPLANATION FOR MICOM CIRCUIT

1-12. Temperature compensation and temperature compensation circuit

1. Temperature compensation in freezer and refrigerator

(1) GR-G277STSA(LSC27990TT)

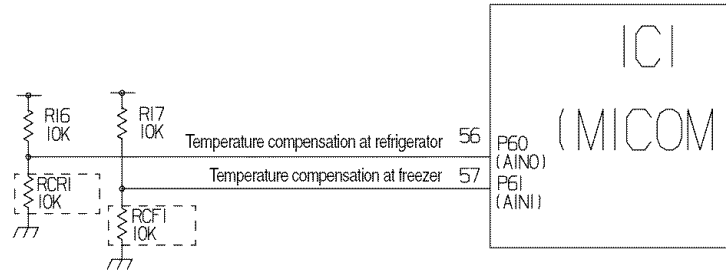

Freezer		Refrigerator		Remarks
Resistance value (RCF1)	Temperature compensation	Resistance value (RCR1)	Temperature compensation	
180 kΩ	+5 °C [+9°F]	180 kΩ	+2.5 °C [+4.5°F]	↑ Warmer
56 kΩ	+4 °C [+7.2°F]	56 kΩ	+2.0 °C [+3.6°F]	
33 kΩ	+3 °C [+5.4°F]	33 kΩ	+1.5 °C [+2.7°F]	
18 kΩ	+2 °C [+3.6°F]	18 kΩ	+1.0 °C [+1.8°F]	
12 kΩ	+1 °C [+1.8°F]	12 kΩ	+0.5 °C [+0.9°F]	
10 kΩ	0 °C [0°F]	10 kΩ	0 °C [0°F]	Reference temperature
8.2 kΩ	-1 °C [-1.8°F]	8.2 kΩ	-0.5 °C [-0.9°F]	↓ Cooler
5.6 kΩ	-2 °C [-3.6°F]	5.6 kΩ	-1.0 °C [-1.8°F]	
3.3 kΩ	-3 °C [-5.4°F]	3.3 kΩ	-1.5 °C [-2.7°F]	
2 kΩ	-4 °C [-7.2°F]	2 kΩ	-2.0 °C [-3.6°F]	
470 Ω	-5 °C [-9°F]	470 Ω	-2.5 °C [-4.5°F]	

► Temperature compensation table by adjustment value (difference value against current temperature)

Ex) If you change compensation resistance at a refrigerator (RCR1) from 10 kΩ (current resistance) to 18 kΩ (modified resistance), the temperature at the refrigerator will increase by +1°C[+1.8°F].

EXPLANATION FOR MICOM CIRCUIT

► Temperature compensation table at the refrigerator is as follows:

	Modification resistance Current resistance	470 Ω	2 kΩ	3.3 kΩ	5.6 kΩ	8.2 kΩ	10 kΩ	12 kΩ	18 kΩ	33 kΩ	56 kΩ	180 kΩ
		Refrigerator (RCR1)	470Ω	No change	0.5 °C [0.9 °F] Up	1 °C [1.8 °F] Up	1.5 °C [2.7 °F] Up	2 °C [3.6 °F] Up	2.5 °C [4.5 °F] Up	3 °C [5.4 °F] Up	3.5 °C [6.3 °F] Up	4 °C [7.2 °F] Up
2 kΩ	0.5 °C [0.9 °F] Down		No change	0.5 °C [0.9 °F] Up	1 °C [1.8 °F] Up	1.5 °C [2.7 °F] Up	2 °C [3.6 °F] Up	2.5 °C [4.5 °F] Up	3 °C [5.4 °F] Up	3.5 °C [6.3 °F] Up	4 °C [7.2 °F] Up	4.5 °C [8.1 °F] Up
3.3 kΩ	1 °C [1.8 °F] Down		0.5 °C [0.9 °F] Down	No change	0.5 °C [0.9 °F] Up	1 °C [1.8 °F] Up	1.5 °C [2.7 °F] Up	2 °C [3.6 °F] Up	2.5 °C [4.5 °F] Up	3 °C [5.4 °F] Up	3.5 °C [6.3 °F] Up	4 °C [7.2 °F] Up
5.6 kΩ	1.5 °C [2.7 °F] Down		1 °C [1.8 °F] Down	0.5 °C [0.9 °F] Down	No change	0.5 °C [0.9 °F] Up	1 °C [1.8 °F] Up	1.5 °C [2.7 °F] Up	2 °C [3.6 °F] Up	2.5 °C [4.5 °F] Up	3 °C [5.4 °F] Up	3.5 °C [6.3 °F] Up
8.2 kΩ	2 °C [3.6 °F] Down		1.5 °C [2.7 °F] Down	1 °C [1.8 °F] Down	0.5 °C [0.9 °F] Drop	No change	0.5 °C [0.9 °F] Up	1 °C [1.8 °F] Up	1.5 °C [2.7 °F] Up	2 °C [3.6 °F] Up	2.5 °C [4.5 °F] Up	3 °C [5.4 °F] Up
10 kΩ	2.5 °C [4.5 °F] Down		2 °C [3.6 °F] Down	1.5 °C [2.7 °F] Down	1 °C [1.8 °F] Down	0.5 °C [0.9 °F] Down	No change	0.5 °C [0.9 °F] Up	1 °C [1.8 °F] Up	1.5 °C [2.7 °F] Up	2 °C [3.6 °F] Up	2.5 °C [4.5 °F] Up
12 kΩ	3 °C [5.4 °F] Down		2.5 °C [4.5 °F] Down	2 °C [3.6 °F] Down	1.5 °C [2.7 °F] Down	1 °C [1.8 °F] Down	0.5 °C [0.9 °F] Down	No change	0.5 °C [0.9 °F] Up	1 °C [1.8 °F] Up	1.5 °C [2.7 °F] Up	2 °C [3.6 °F] Up
18 kΩ	3.5 °C [6.3 °F] Down		3 °C [5.4 °F] Down	2.5 °C [4.5 °F] Down	2 °C [3.6 °F] Down	1.5 °C [2.7 °F] Down	1 °C [1.8 °F] Down	0.5 °C [0.9 °F] Down	No change	0.5 °C [0.9 °F] Up	1 °C [1.8 °F] Up	1.5 °C [2.7 °F] Up
33 kΩ	4 °C [7.2 °F] Down		3.5 °C [6.3 °F] Down	3 °C [5.4 °F] Down	2.5 °C [4.5 °F] Down	2 °C [3.6 °F] Down	1.5 °C [2.7 °F] Down	1 °C [1.8 °F] Down	0.5 °C [0.9 °F] Down	No change	0.5 °C [0.9 °F] Up	1 °C [1.8 °F] Up
56 kΩ	4.5 °C [8.1 °F] Down		4 °C [7.2 °F] Down	3.5 °C [6.3 °F] Down	3 °C [5.4 °F] Down	2.5 °C [4.5 °F] Down	2 °C [3.6 °F] Down	1.5 °C [2.7 °F] Down	1 °C [1.8 °F] Down	0.5 °C [0.9 °F] Down	No change	0.5 °C [0.9 °F] Up
180 kΩ	5 °C [9 °F] Down	4.5 °C [8.1 °F] Down	4 °C [7.2 °F] Down	3.5 °C [6.3 °F] Down	3 °C [5.4 °F] Down	2.5 °C [4.5 °F] Down	2 °C [3.6 °F] Down	1.5 °C [2.7 °F] Down	1 °C [1.8 °F] Down	0.5 °C [0.9 °F] Down	No change	

► Temperature compensation at the freezer is performed the same as at the refrigerator. The value for the freezer is twice that of the refrigerator.

► This circuit enters the necessary level of temperature compensation for adjusting the appliance. The method is the same for every model in this appliance family.

EXPLANATION FOR MICOM CIRCUIT

2. Compensation circuit for temperature at freezer

(1) GR-G277STSA(LSC27990TT)

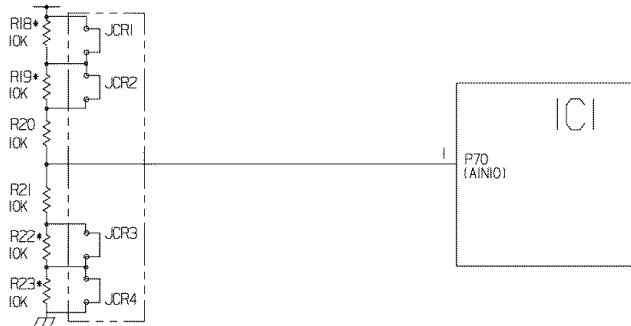

Temperature compensation in CUT		
JCR1	+1 °C [+1.8 °F]	+2 °C [+3.6 °F]
JCR2	+1 °C [+1.8 °F]	
JCR3	-1 °C [-1.8 °F]	-2 °C [-3.6 °F]
JCR4	-1 °C [-1.8 °F]	

Compensation for too warm		Compensation for too cold		Temperature compensation value at refrigerator	Remarks
JCR3	JCR4	JCR1	JCR2		
				0 °C [In shipment from factory]	
CUT				-1 °C [-1.8 °F]	
	CUT			-1 °C [-1.8 °F]	
		CUT		+1 °C [+1.8 °F]	
			CUT	+1 °C [+1.8 °F]	
CUT	CUT			-2 °C [-3.6 °F]	
		CUT	CUT	+2 °C [+3.6 °F]	
CUT		CUT		0 °C [0 °F]	
CUT			CUT	0 °C [0 °F]	
	CUT	CUT		0 °C [0 °F]	
	CUT		CUT	0 °C [0 °F]	
CUT	CUT	CUT		-1 °C [-1.8 °F]	
	CUT	CUT	CUT	+1 °C [+1.8 °F]	
CUT	CUT	CUT	CUT	0 °C [0 °F]	

► This circuit allows adjustment of the set temperature for compensation by changing jumpers at locations JCR1~JCR4.

EXPLANATION FOR MICOM CIRCUIT

1-13. Communication circuit and connection L/Wire between main PCB and display PCB

The following communication circuit is used for exchanging information between the main MICOM of the Main PCB and the dedicated MICOM of the LCD Display PCB.

A bi-directional lead wire assembly between the two boards is required for the display to function properly.

Poor communication occurs if a continuous information exchange fail to continue for more than 2 minutes between main MICOM of main PCB and LCD dedicated MICOM for LCD control of display PCB.

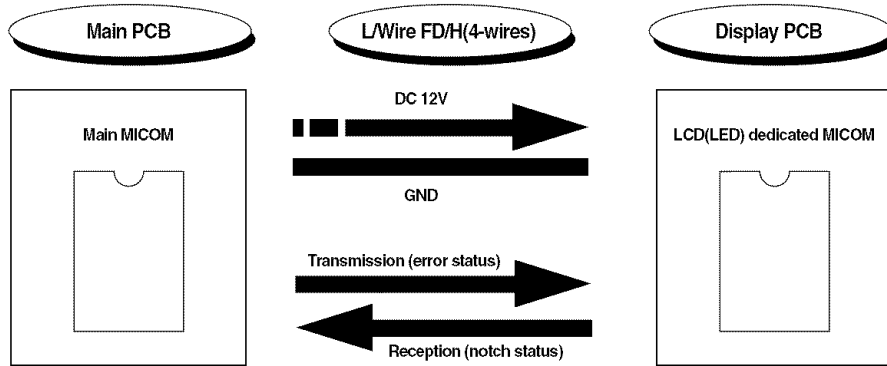

(1) GR-G277STSA(LSC27990TT)

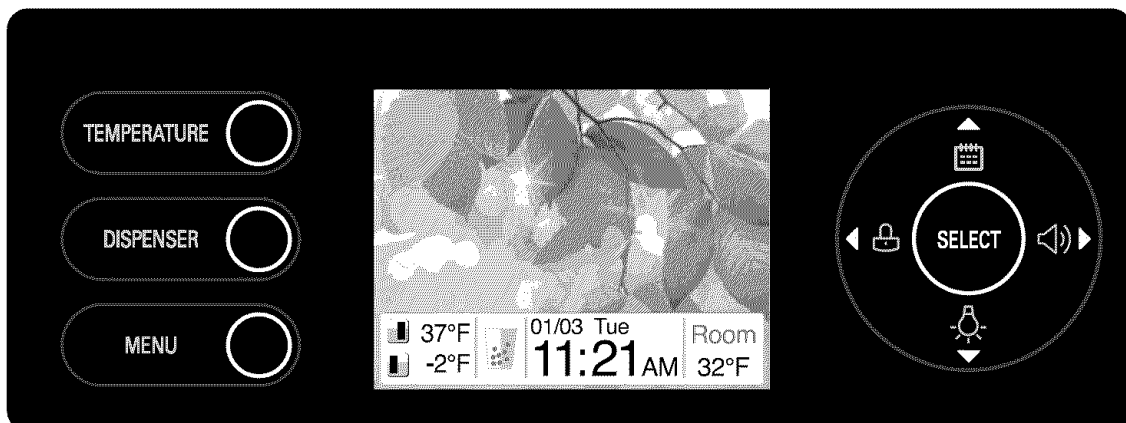
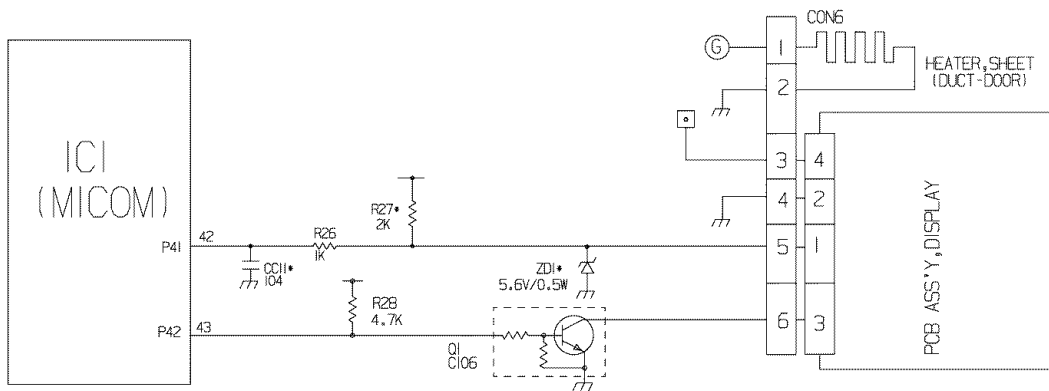

EXPLANATION FOR MICOM CIRCUIT

2) Sensor resistance characteristics table

Measuring Temperature (°C)	Freezing Sensor	Refrigerator sensor 1&2 Defrost sensor, Ambient sensor
-20 °C	22.3 kΩ	77 kΩ
-15 °C	16.9 kΩ	60 kΩ
-15 °C	13.0 kΩ	47.3 kΩ
-5 °C	10.1 kΩ	38.4 kΩ
0 °C	7.8 kΩ	30 kΩ
+5 °C	6.2 kΩ	24.1 kΩ
+10 °C	4.9 kΩ	19.5 kΩ
+15 °C	3.9 kΩ	15.9 kΩ
+20 °C	3.1 kΩ	13 kΩ
+25 °C	2.5 kΩ	11 kΩ
+30 °C	2.0 kΩ	8.9 kΩ
+40 °C	1.4 kΩ	6.2 kΩ
+50 °C	0.8 kΩ	4.3 kΩ

- ▶ Resistance value allowance of sensor is $\pm 5\%$.
- ▶ When measuring the resistance value of the sensor, allow the temperature of that sensor to stabilize for at least 3 minutes before measuring. This delay is necessary because of the sense speed relationship.
- ▶ Use a digital tester to measure the resistance. An analog tester has to great a margin of error.
- ▶ Resistance of the cold storage sensor 1 and 2 shall be measured with a digital tester after separating CON8 of the PWB ASSEMBLY and the MAIN part.
- ▶ Resistance of the freezing sensor shall be measured with a digital tester after separating CON7 of the PWB ASSEMBLY and the MAIN part.

EXPLANATION FOR MICOM CIRCUIT

1-14. OptiFresh stepping MOTOR/Display

(1) GR-G277STSA(LSC27990TT)

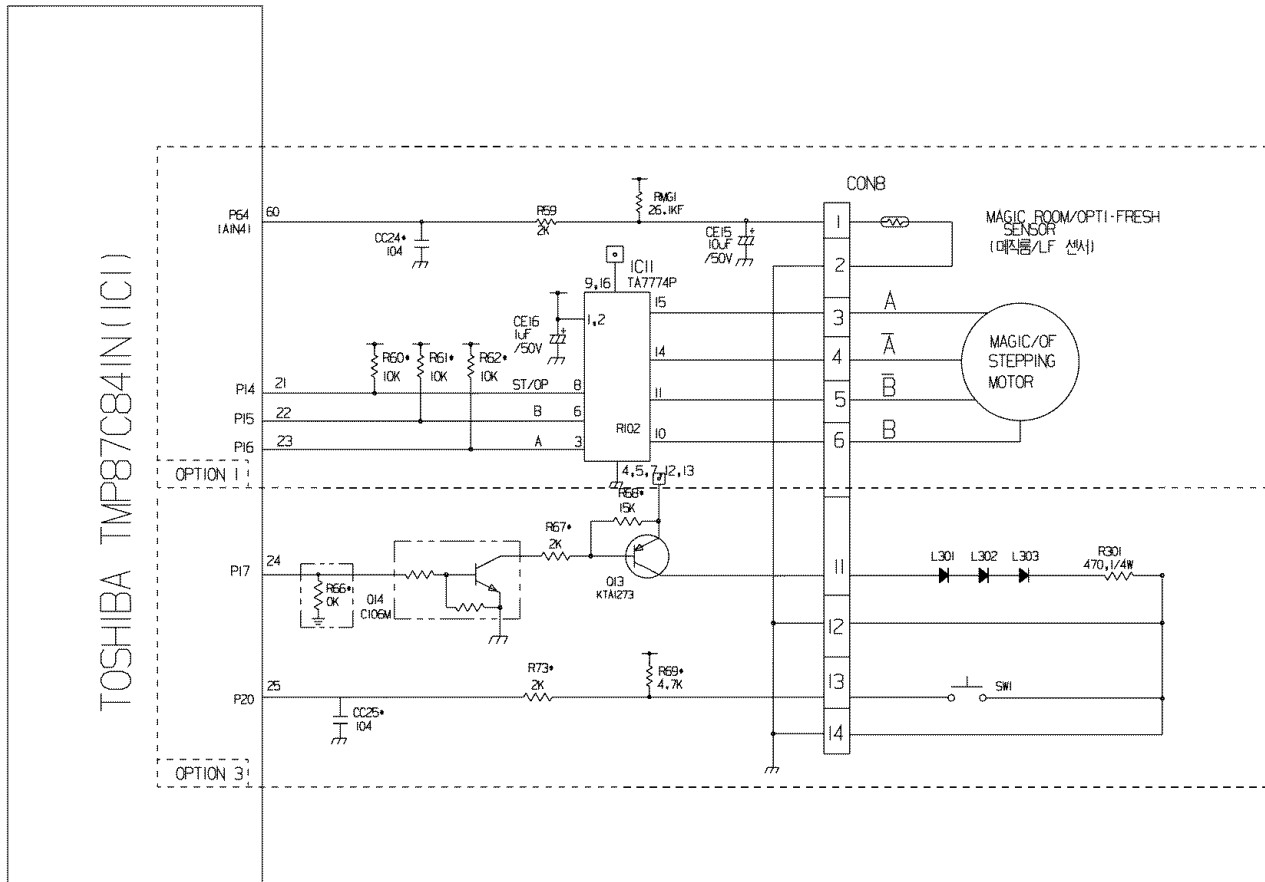

EXPLANATION FOR MICOM CIRCUIT

2. PWB parts diagram and list

2-1. PWB Assembly, main part diagram

(1) GR-G277STSA(LSC27990TT)

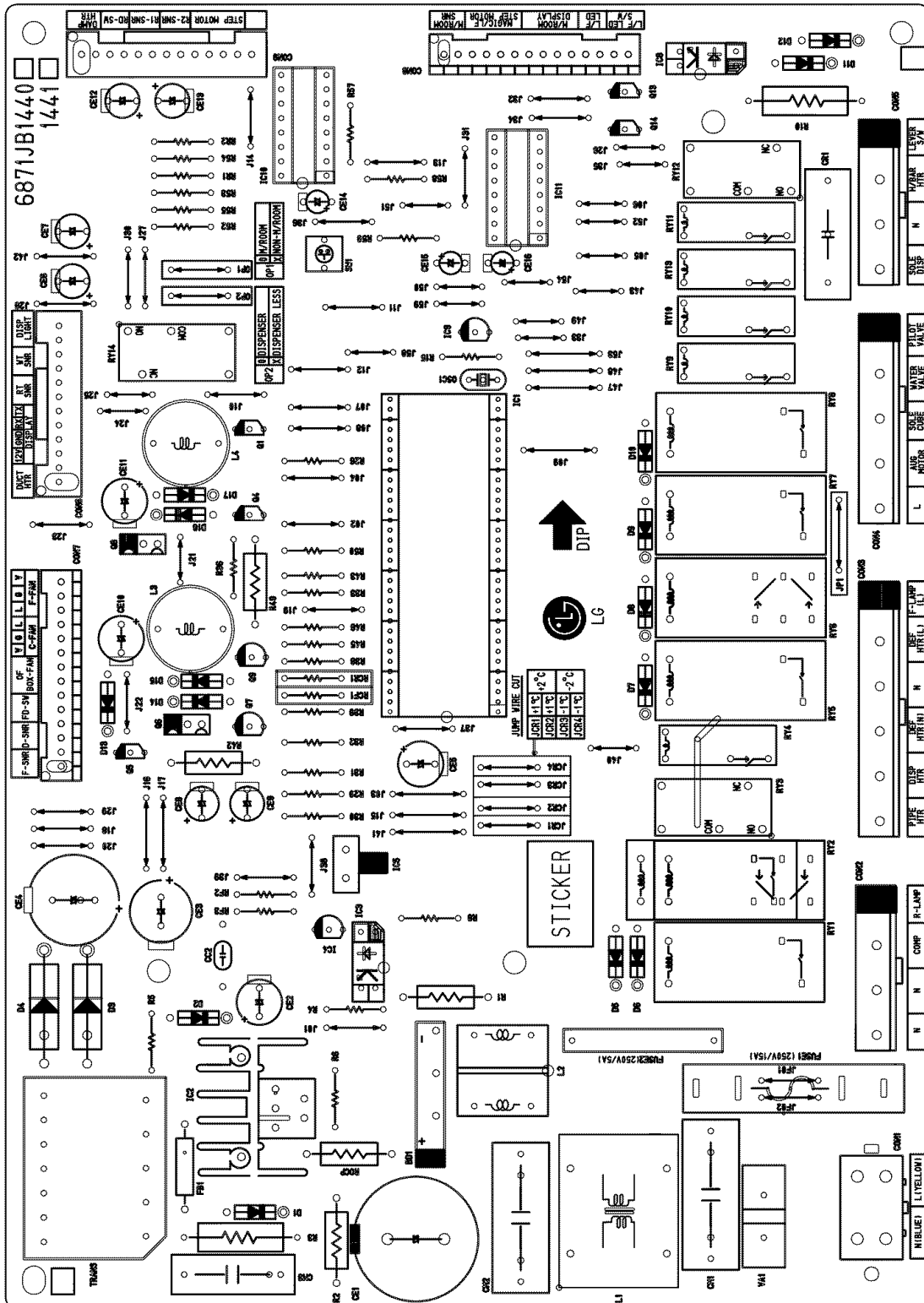

EXPLANATION FOR MICOM CIRCUIT

No	P/NO	DESCRIPTION	SPEC	MAKER	REMARK
143	4530.EE3007A	HEAT SINK	29.917425 DRIVE IC STR R-96A/65V/3 ZPIN 1-SCHEW 3AM	TAI SUNG	(1C2)
144	4530.0324B	SCREW	* 03.0 LB.0 45NR37Z1	-	(1C2)
145	655000000AA	SOLDER(BOSIN WIRE) R50	SR-94 RB FREE, LFM-46	-	-
146	58200.025AA	SOLDER(SOLDERING)	LFM-90 SN 3.046-0.302Z 3.0MM	HE SUNG	-
147	724528000AA	FLUX	SR-94P-05 KOK 12.5 RTX 0.18H+0.003	KOKI	-
148	000103F	CONNECTOR (CIRC), WAFER	6P8B191-2 HAN KUK DAN JA NA NA NA	KEI	TAB. 2
149	0122.EE3007A	C. DRAWING	IMP/PMAN 64 SDIP ST BIC5-PJT BATTERY MASK	TOSHIBA	IC1 (0122.EE3006,01P)
150	0122.EE****	C. DRAWING	IMP/PMAN 64 SDIP ST BIC5-PJT BATT MASK	TOSHIBA	IC1
151	65546E3000A	LAMP WIRE	0.6MM 3AM TP TAPING SN	-	F01, F02
152					
153					
154					
155					
156					
157					

EXPLANATION FOR MICOM CIRCUIT

2-3. DISPLAY ASSEMBLY part diagram

(1) GR-G277STSA(LSC27990TT)

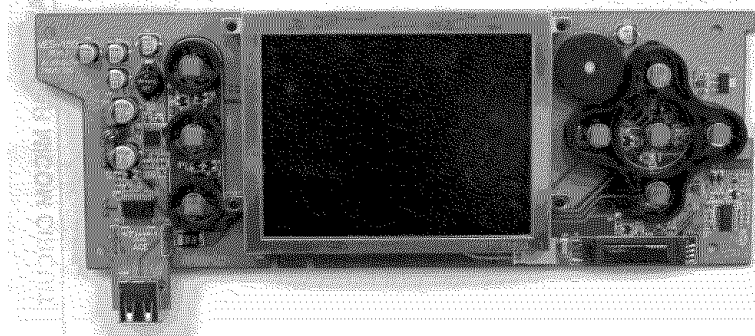

No.	품목코드	품목명	규격	단위	소요량
1	A01010088	32BIT RISC MICROPROCESSOR - SAMSUNG	S3C2410A20-YO80	EA	1
2	A01030086	TTL IC - SO14	74LV14D	EA	1
3	A01040024	PIC - MACROCHIP	PIC18F2520 (SO28) - LG 냉장고	EA	1
4	A01050043	MOSFET SWITCH	SI3861 DV (SSOT6)	EA	1
5	A01050046	POWER MOSFET - ADV POWER	9930M (SO8)	EA	1
6	A01060002	TRANSISTOR-PNP - ONSEMI	MMBT3906LT1-SOT23	EA	2
7	A01060003	TRANSISTOR-NPN - ONSEMI	MMBT3904LT1-SOT23	EA	6
8	A01060029	TRANSISTOR-PNP - KEC	KRA106S-SOT23	EA	1
9	A01060030	TRANSISTOR-NPN - KEC	KRC106S-SOT23	EA	2
10	A01070002	DIODE	LL4148-GS08 MELF	EA	3
11	A01070007	DIODE	BAT54S	EA	1
12	A01070015	DIODE - ONSEMI	MBR0520L T3/T1	EA	1
13	A01070056	Switching Diode - ROHM	1SS380 (SC-79)	EA	1
14	A01070058	ZENER DIODE - ROHM	UDZS 7.5B / SC-76	EA	3
15	A01080002	LED-0805	LED GREEN (SML-210MTT86)	EA	1
16	A01080030	LED-0805	LED WHITE	EA	17
17	A01090005	SWITCHING POWER	LM2653MTCX-ADJ	EA	1
18	A01090079	REGULATOR	AS1117-1.5V (SOT223) / SPX1117-1.5V	EA	1
19	A01090106	REGULATOR - NATIONAL	LP3965EMP-ADJ (SOT223-5)	EA	1
20	A01090128	REGULATOR - ST	LD1117S33TR (SOT223)	EA	1
21	A01090129	REGULATOR - ST	LD1117S18TR (SOT223)	EA	1
22	A01110062	MEMORY - SDRAM - HYNIX/SAMSUNG	HY57V561620CT-H / K4S561632C-TC75	EA	2
23	A01110081	MEMORY - NOR FLASH - ST	M29W800DB70N6 (TSOP48)	EA	1
24	A01110084	MEMORY - NAND FLASH - SAMSUNG	K9F1G08U0M-PCB0 (TSOP48)	EA	1
25	A01140017	ZVS CCFL CONTROLLER - BITECH	BIT 3105 (SSOP20)	EA	1
26	A01140025	RS-232 - INTERSIL	HIN213ECAZ-T (Pbfree용)	EA	1
27	A01150055	TOUCH SENSOR - AD반도체	TS01 (SSOT6)	EA	8
28	A02010001	Resistor-J	0Ω-5%-0603 (RC1608J000CS)	EA	12
29	A02010014	Resistor-J	22Ω-5%-0603 (RC1608J220CS)	EA	20
30	A02010032	Resistor-J	100Ω-5%-0603 (RC1608J101CS)	EA	1
31	A02010034	Resistor-J	150Ω-5%-0603	EA	17
32	A02010038	Resistor-J	220Ω-5%-0603 (RC1608J221CS)	EA	1
33	A02010044	Resistor-J	330Ω-5%-0603 (RC1608J331CS)	EA	4
34	A02010049	Resistor-J	470Ω-5%-0603 (RC1608J471CS)	EA	2
35	A02010057	Resistor-J	820Ω-5%-0603	EA	1
36	A02011001	Resistor-J	1KΩ-5%-0603 (RC1608J102CS)	EA	11
37	A02011003	Resistor-J	1.2KΩ-5%-0603 (RC1608J122CS)	EA	1
38	A02011017	Resistor-J	4.7KΩ-5%-0603 (RC1608J472CS)	EA	9
39	A02011026	Resistor-J	10KΩ-5%-0603 (RC1608J103CS)	EA	26
40	A02011028	Resistor-J	15KΩ-5%-0603	EA	2
41	A02011031	Resistor-J	20KΩ-5%-0603 (RC1608J203CS)	EA	1
42	A02011033	Resistor-J	22KΩ-5%-0603 (RC1608J223CS)	EA	2
43	A02011041	Resistor-J	47KΩ-5%-0603	EA	1
44	A02011045	Resistor-J	62KΩ-5%-0603 (RC1608J623CS)	EA	3
45	A02011046	Resistor-J	75KΩ-5%-0603	EA	1
46	A02012001	Resistor-J	100KΩ-5%-0603	EA	1

EXPLANATION FOR MICOM CIRCUIT

47	A02012003	Resistor-J	120KΩ-5%-0603 (RC1608J124CS)	EA	1
48	A02012006	Resistor-J	270KΩ-5%-0603	EA	1
49	A02012009	Resistor-J	510KΩ-5%-0603	EA	1
50	A02012011	Resistor-J	1MΩ-5%-0603 (RC1608J105CS)	EA	2
51	A02012024	Resistor-J	200KΩ-5%-0603	EA	1
52	A02012034	Resistor-J	360KΩ-5%-0603	EA	1
53	A02021028	Resistor-F	20KΩ-1%-0603 (RC1608F2002CS)	EA	1
54	A02021039	Resistor-F	60.4KΩ-1%-0603 (RC1608F6042CS)	EA	1
55	A02022020	Resistor-F	820KΩ-1%-0603 (RC1608F8203CS)	EA	1
56	A02022037	Resistor-F	560KΩ-1%-0603	EA	6
57	A02022038	Resistor-F	330KΩ-1%-0603	EA	2
58	A02031007	Chip Resistor Networks 4ARRAY	10KΩ-4ARRAY (RP164PJ103CS)	EA	3
59	A03012017	STARCAP - KORCHIP	0.33F/2.5V (SCDM2R5334)	EA	1
60	A03021005	Aluminum Electrolytic CAP	47uF-16V-6.3Φ (SC1C476M6L005VR100)	EA	1
61	A03022001	Aluminum Electrolytic CAP	100uF-16V-6.3Φ (SC1C107M6L005VR259)	EA	3
62	A03022002	Aluminum Electrolytic CAP	330uF-16V-8Φ (GC1C337M08010VR100)	EA	2
63	A03022014	Aluminum Electrolytic CAP	220uF-16V-6.3Φ-CK series - 삼화콘덴서	EA	3
64	A03031009	Tantal CAP	10uF-16V-A	EA	21
65	A03031037	Tantal CAP - 삼성전기	10uF-10V-P (TCSCS1A106MPAR)	EA	4
66	A03032001	Tantal CAP	100uF-16V-D	EA	1
67	A03040007	칩세라믹콘덴서(0603)	15pF-0603 (CL10C150JB8NNNC)	EA	2
68	A03040012	칩세라믹콘덴서(0603)	22pF-0603	EA	2
69	A03040017	칩세라믹콘덴서(0603)	33pF-0603	EA	2
70	A03040024	칩세라믹콘덴서(0603)	100pF-0603 (CL10C101JB8NNNC)	EA	3
71	A03040030	칩세라믹콘덴서(0603)	220pF-0603	EA	1
72	A03040043	칩세라믹콘덴서(0603)	12pF-0603	EA	10
73	A03040052	칩세라믹콘덴서(1808)	5pF(3KV)-1808 (302R29N5R0CV4E)	EA	1
74	A03041005	칩세라믹콘덴서(0603)	2.2nF-0603 (CL10B222KB8NNNC)	EA	1
75	A03041007	칩세라믹콘덴서(0603)	2.7nF-0603 (CL10B272KB8NNNC)	EA	1
76	A03041012	칩세라믹콘덴서(0603)	10nF-0603 (CL10B103KB8NNNC)	EA	12
77	A03041018	칩세라믹콘덴서(0603)	47nF-0603 (CL10B473KA8NNNC)	EA	3
78	A03041021	칩세라믹콘덴서(0603)	100nF-0603 (CL10F104ZA8NNNC)	EA	42
79	A03041022	칩세라믹콘덴서(0805)	100nF-0805 (CL10F104Z08NNNC)	EA	1
80	A03042001	칩세라믹콘덴서(0603)	1uF-0603 (CL10B223KB8NNNC)	EA	14
81	A03042012	칩세라믹콘덴서(1206) TDK	10uF/1206/16V/Y5V (C3216Y5V1C106Z)	EA	2
82	A03042013	칩세라믹콘덴서(1206) TDK	4.7uF/1206/25V/Y5V (C3216Y5V1E475Z)	EA	1
83	A04010001	답바드	BFR601009C8MGH	EA	1
84	A04020015	Chip Ferrite Bead (CERATECH)	120Ω-2A-0805 (HH-1M2012-121JT)	EA	11
85	A04040010	Chip Coil	DO3316P-223(22uH) 2.6A	EA	1
86	A04050006	TRANS	TRANS UI 8.5mm	EA	1
87	A05010001	CRYSTAL - RALTRON - SMD	32.768KHz (SERIES RSM200S)	EA	2
88	A05010004	CRYSTAL	12MHz-JX-1/SMD (JTC-JX-1-12-20-6E7)	EA	1
89	A05010030	CRYSTAL	9.8304MHz - HC49S/SMD	EA	1
90	A06030005	PIN HEADER-SINGLE ROW-Straight	PIN Header 4P-1ROW-2.54mm-S	EA	2
91	A06060003	USB CONNECTOR	USB A Type Single-shield-R/A 787616-2	EA	1
92	A06090032	BUZZER (LG)	BM-20B/4KHZ-85DB	EA	1
93	A06100239	JST CONNECTOR	SM02B-BHSS-1-TB	EA	1
94	A06100240	연호전자 CONNECTOR	SMAW250-04G	EA	1
95	A06100241	우주일렉트로닉스 CONNECTOR	FF100-S40B-C25(D)	EA	1
96	A06100274	연호전자 CONNECTOR	SMAW250-03	EA	1
97	A06100278	한림전자 CONNECTOR	HL2002-S2G-N 14PIN-2ROW	EA	1
98	A08020139	LCD CABLE (FFC) (LG냉장고용)	40P-40P/40mm/1mm pitch MES-110 LCD CABLE	EA	1
99	A09010060	LCD - LG	LB040Q02-TD01 - 4" LCD	EA	1
100	A10010471	PB051206	MES-150 R1.1 Pbfree	EA	1
101	A12020079	낮은 납비머리나사	CM2x4xΦ3.5 BK	EA	4
102	A12030029	BOSS	황동 10.6 * Φ4 M2 관통(LG)	EA	4
103	A17020012	실드폼 가스켓 - AD 반도체	5.5X3.5X5.5 BLOCK	EA	4
104	A17020014	실드폼 가스켓 - AD 반도체	5.5×2.0×5.5 R	EA	1
105	A17020015	실드폼 가스켓 - AD 반도체	5.5×3.0×5.5 R	EA	1
106	A18080006	ELECTRODE - AD반도체	압정봉 12mm	EA	3
107	A18080007	정전기 SWITCH 사출물 - LG 2세대 아바타	압정봉 12mm 1구 사출물 - LG 2세대 아바타	EA	3
108	A18080008	정전기 SWITCH 사출물 - LG 2세대 아바타	압정봉 12mm 5구 사출물 - LG 2세대 아바타	EA	1
109	A60010028	PROGRAM OS - WIN CE.4.2 CORE LIC	WIN CE LIC LABEL	EA	1

EXPLANATION FOR MICOM CIRCUIT

2-4. DISPLAY circuit diagram

(1) GR-G277STSA(LSC27990TT)

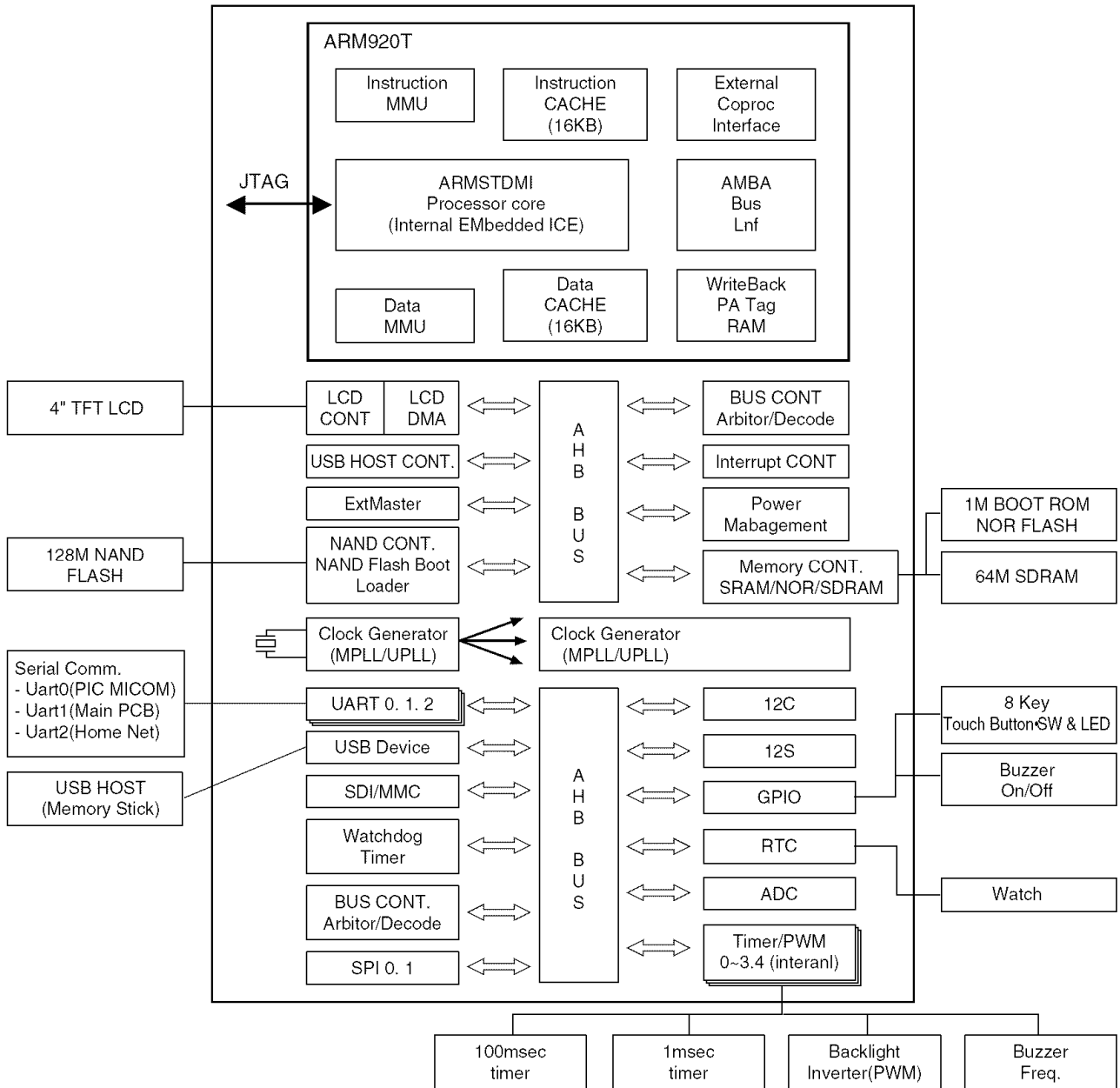

EXPLANATION FOR MICOM CIRCUIT

3. PWB Circuit Diagram may vary by model.

(1) GR-G277STSA(LSC27990TT)

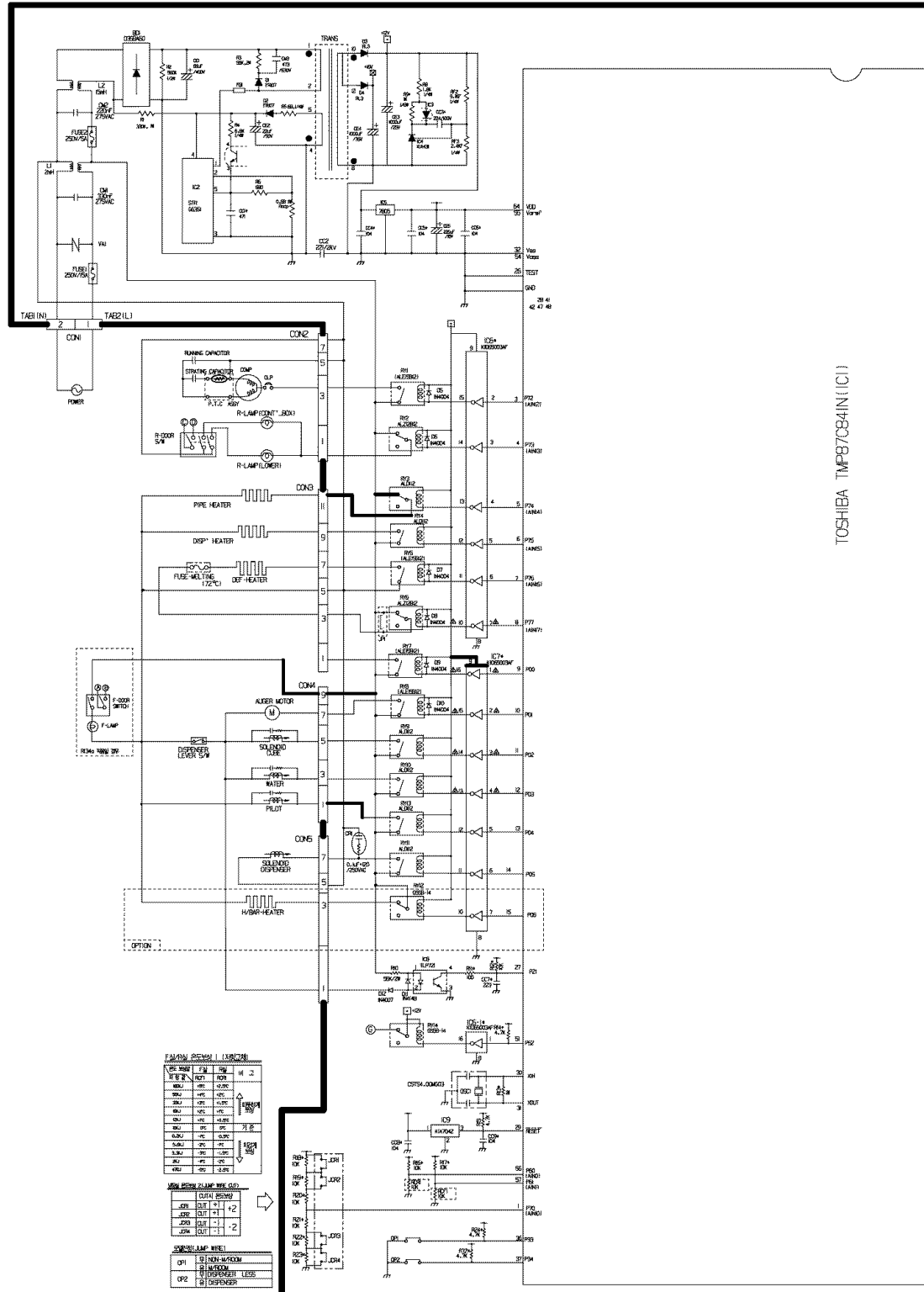

TOSHIBA TMB7C84IN (C1)

EXPLANATION FOR MICOM CIRCUIT

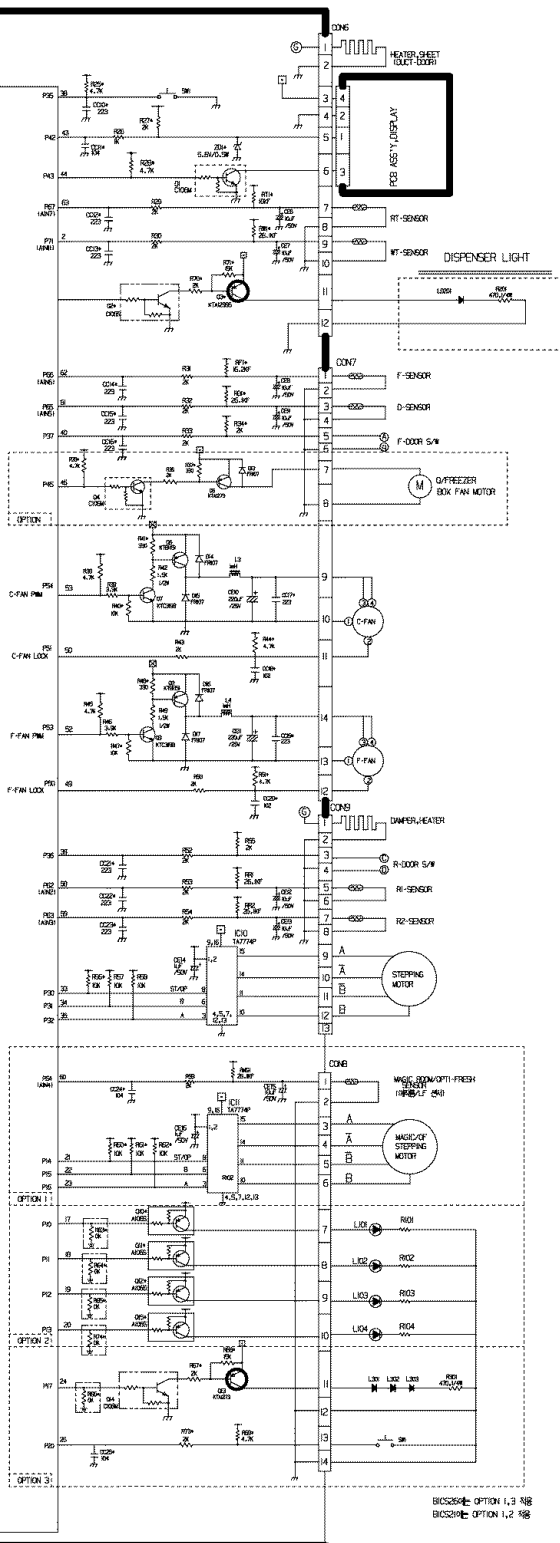

ICEMAKER AND DISPENSER WORKING PRINCIPLES AND REPAIR

1. OPERATION PRINCIPLE

1-1. Operation Principle of Icemaker

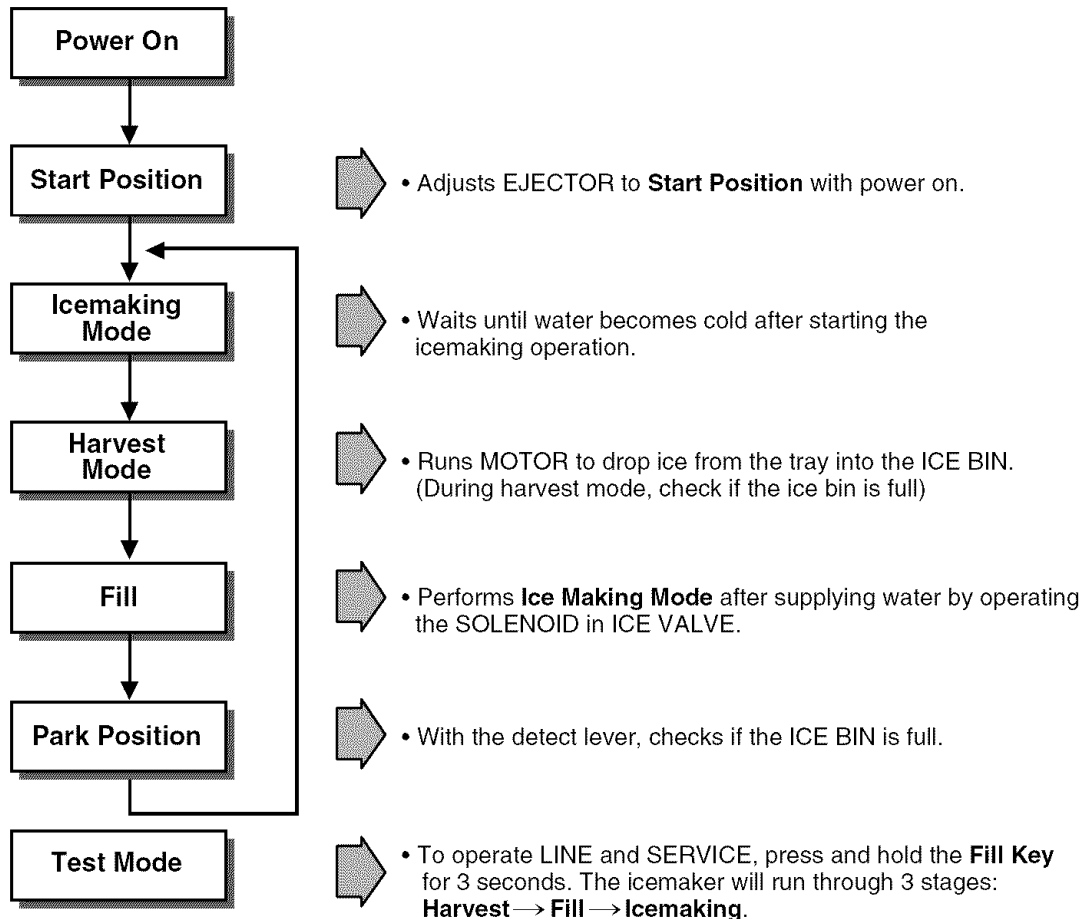

1. Turning the Icemaker stop switch off (O) stops the ice making function.
2. Setting the Icemaker switch to OFF and then turning it back on will reset the icemaker control.

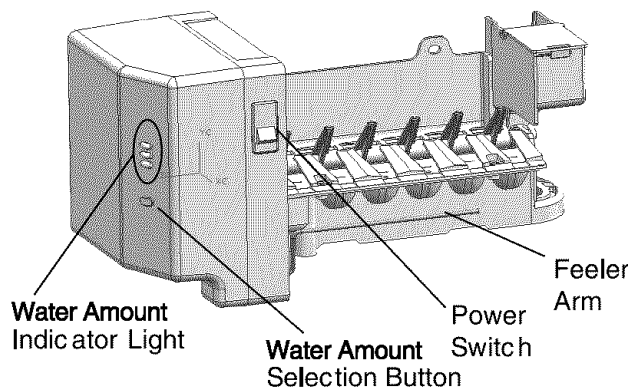

ICEMAKER AND DISPENSER WORKING PRINCIPLES AND REPAIR

2. ICEMAKER FUNCTIONS

2-1. Start Position

1. After POWER OFF or power outage, check the EJECTOR's position with MICOM initialization to restart.
2. How to check if it is in place:
 - Check **HIGH/LOW** signals from HALL SENSOR in MICOM PIN.
3. Control Method to check if it is in place:
 - (1) EJECTOR is in place,
 - It is an initialized control, so the mode can be changed to icemaking control.
 - (2) EJECTOR isn't in place:
 - A. If EJECTOR is back in place within 2 minutes with the motor on, it is being initialized. If not, go to Step B.
 - B. If EJECTOR is back in place within 18 minutes after the heater turns from ON to OFF, it is being initialized. If not, it is not functioning. Repeat Step B with Heater and Motor off.

2-2. Icemaking Mode

1. Icemaking refers to the freezing of supplied water in the ice trays. Complete freezing is assured by measuring the temperature of the Tray with Icemaking SENSOR.
2. Icemaking starts after completion of the water fill operation.
3. The Ice Making function is completed when the sensor reaches 19°F (-7°C), 1 ~ 4 hours after starting.
4. If the temperature sensor is defective, the ice-making function will be completed in 4 hours.

NOTE : After Icemaker Power is ON, the Icemaker heater will be on for test for 9 sec.



2-3. Harvest Mode

1. Harvest (Ice removing) refers to the operation of dropping cubes into the ice bin from the tray when icemaking has completed.
2. Harvest mode:
 - (1) The Heater is ON for 30 seconds, then the motor starts.
 - (2) After performing Step 1 (the Heater is turned OFF), the Ejector will be back in place within 18 minutes. (Hall SENSOR sign = OV). Ice removal is then complete. Then the Icemaker cycles to the Fill Mode. The water supply fails to start, it is not functioning. Put the Heater and Motor in the off position. Restart every 2 hours. (Refer to fig.1)

2-4. Fill/Park Position

1. Once a normal harvest mode has been completed, the water solenoid will be activated.
2. The amount of water is adjusted by pressing the Fill Key repeatedly. This changes the time allowed for fill as illustrated in the table below.

Water supply amount TABLE





STAGE	TIME TO SUPPLY	INDICATIONS	REMARKS
1	5 sec.		The water amount will vary depending on the water control switch setting, as well as the water pressure of the connected water line.
2	5.5 sec. (FIRST STAGE)		
3	6 sec.		

ICEMAKER AND DISPENSER WORKING PRINCIPLES AND REPAIR

2-5. Function TEST

1. This is a forced operation for TEST, Service, cleaning, etc. It is operated by pressing and holding the Fill Key for 3 seconds.
2. The test works only in the Icemaking Mode. It cannot be entered from the Harvest or Fill mode. (If there is an ERROR, it can only be checked in the TEST mode.)
3. **Caution!** If the test is performed before water in the icemaker is frozen, the ejector will pass through the water. When the Fill mode begins (Stage 4), unless the water supply has been shut off, added water will overflow into the ice bin. If the control doesn't operate normally in the TEST mode, check and repair as needed.
4. After water is supplied, the normal CYCLE is followed: **icemaking** → **Harvest** → **Fill** → **Park Position**.
5. Five seconds after Stage 5 is completed, the Ice Maker returns to MICOM control. The time needed to supply water resets to the pre- test setting.

Diagnosis TABLE

STAGE	ITEMS	INDICATOR	REMARKS
1	HEATER		Five seconds after heater starts, a heater will go off if the temperature by sensor is higher than 20°C
2	MOTOR		Five seconds after heater starts, you can confirm that a motor is moving.
3	HALL IC I (detection of position)		After the icemaker detects that ice has been made, the motor and heater are off but on standby until the cycle is cancelled.
4	HALL IC II (detection of position)		You can confirm HALL IC detection of position.
5	VALVE		Two seconds after detection of initial position, you can confirm that valve is on.
6	Reset	Return to Status prior to TEST MODE	Five seconds after fifth stage is completed, The icemaker resets to initial status.

3. DEFECT DIAGNOSIS FUNCTION

3-1. ERROR CODES shown on Icemaker water supply control panel

NO	DIVISION	INDICATOR	CONTENTS	REMARKS
1	Normal	Mark time to supply	None	Display switch operates properly
2	Icemaking Sensor malfunction		Open or short-circuited wire	Make sure that the wire on each sensor is connected.

ERROR indicators in table can be checked only in TEST mode.

CIRCUIT

(1) GR-G277STSA(LSC27990TT)

CIRCUIT DIAGRAM

DELUXE

- H /BAR PART(H/BAR HEATER,DOOR SW),CAPACITOR PART, PLUG TYPE, COMPRESSOR EARTH PART, P.T.C ASSEMBLY ON CIRCUIT DIAGRAMS ARE SUBJECT TO CHANGE IN DIFFERENT LOCALITES AND ACCORDANCE WITH MODEL TYPE.

- N : NEUTRAL

* FUSE PART APPLICATION(OPTIONAL)

FUSE	
100-127V	220-240V
NO FUSE	250VAC 15A

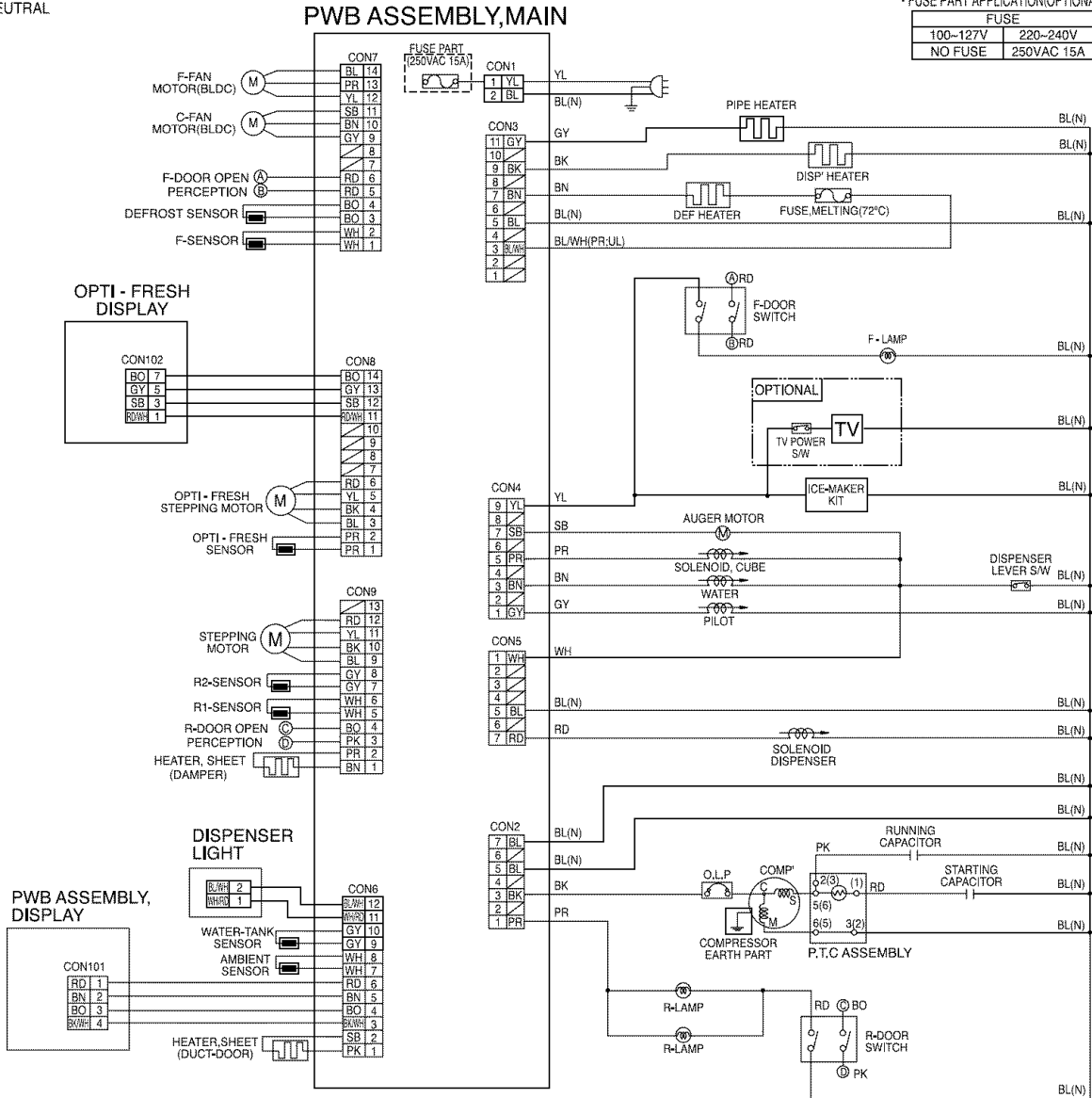

BK : BLACK	BN : BROWN	BO : BRIGHT ORANGE	GY : GRAY	RD : RED
YL : YELLOW	GN : GREEN	PR : PURPLE	WH : WHITE	WH/BK : WHITE/BLACK
SB : SKY BLUE	PK : PINK	GN/YN : GREEN/YELLOW	BL/WH : BLUE/WHITE	RD/WH : RED/WHITE

TROUBLE DIAGNOSIS

1. Troubleshooting

CLAIMS.	CAUSES AND CHECK POINTS.	HOW TO CHECK
<p>1. Faulty start</p>	<p>1) No power at outlet.</p> <p>2) No power on cord.</p> <ul style="list-style-type: none"> └ Bad connection between plug and adapter (faulty plug). <ul style="list-style-type: none"> └ The distance between pins. └ Pin outer diameter. <p>3) Shorted start circuit.</p> <ul style="list-style-type: none"> └ No power on power cord. <ul style="list-style-type: none"> └ Disconnected copper wire. <ul style="list-style-type: none"> └ Power cord is disconnected. └ Faulty soldering. └ Internal electrical short. └ Faulty terminal contact. <ul style="list-style-type: none"> └ Loose contact. <ul style="list-style-type: none"> - Large distance between male terminal. - Thin female terminal. └ Terminal disconnected. └ Bad sleeve assembly. └ Disconnected. <ul style="list-style-type: none"> └ Weak connection. └ Short inserted cord length. └ Worn out tool blade. └ OLP is off. <ul style="list-style-type: none"> └ Capacity of OLP is small. └ Characteristics of OLP is bad. └ Bad connection. └ Power is disconnected. <ul style="list-style-type: none"> └ Inner Ni-Cr wire blows out. └ Bad internal connection. └ Faulty terminal caulking (Cu wire is cut). └ Bad soldering. └ No electric power on compressor. - Faulty compressor. └ Faulty PTC. <ul style="list-style-type: none"> └ Power does not conduct. - Damage. └ Bad characteristics. - Initial resistance is high. └ Bad connection with compressor. <ul style="list-style-type: none"> └ Too loose. └ Assembly is not possible. └ Bad terminal connection. <p>4) During defrost.</p> <ul style="list-style-type: none"> └ Start automatic defrost. <ul style="list-style-type: none"> └ Cycle was set at defrost when the refrigerator was produced. 	<p>* Measuring instrument: Multi tester</p> <ul style="list-style-type: none"> ■ Check the voltage. If the voltage is within $\pm 15\%$ of the rated voltage, it is OK. ■ Check the terminal movement. ■ Check both terminals of power cord. Power conducts: OK. No power conducts: NG ■ Check both terminals of OLP If power conducts: OK. If not: NG. ■ Check the resistance of both terminals. At normal temperature 6: OK. If disconnected: ∞.

TROUBLE DIAGNOSIS

CLAIMS.	CAUSES AND CHECK POINTS.	HOW TO CHECK
<p>2. No cooling.</p>	<p>2) Refrigeration system is clogged.</p> <ul style="list-style-type: none"> - Moisture clogged. <ul style="list-style-type: none"> - Residual moisture in the evaporator. <ul style="list-style-type: none"> - Air Blowing. <ul style="list-style-type: none"> - Not performed. - Too short. - Impossible moisture confirmation. - Low air pressure. - Leave it in the air. <ul style="list-style-type: none"> - During rest time. - After work. - Caps are missed. - Residual moisture. <ul style="list-style-type: none"> - Not dried in the compressor. - Elapsed more than 6 months after drying - Caps are missed. - No pressure when it is open. - No electric power on thermostat. <ul style="list-style-type: none"> - Insufficient drier capacity. <ul style="list-style-type: none"> - Dry drier - Drier temperature. - Air dry <ul style="list-style-type: none"> - Check on package condition. - Good storage after finishing. - Residual moisture in pipes. <ul style="list-style-type: none"> - Caps are missed. <ul style="list-style-type: none"> - During transportation. - During work. - Air blowing. <ul style="list-style-type: none"> - Not performed. - Performed. <ul style="list-style-type: none"> - Too short time. - Low air pressure. - Less dry air. - Moisture penetration - Leave it in the air. - Moisture penetration into the refrigeration oil. - Weld joint clogged. <ul style="list-style-type: none"> - Short pipe insert. - Pipe gaps. <ul style="list-style-type: none"> - Too large. - Damaged pipes. - Too much solder. - Drier clogging. <ul style="list-style-type: none"> - The capillary tube inserted depth. - Too much. - Capillary tube melts. - Over heat. - Clogged with foreign materials. <ul style="list-style-type: none"> - Desiccant powder. - Weld oxides. - Drier angle. - Reduced cross section by cutting. - Squeezed. - Foreign material clogging. <ul style="list-style-type: none"> - Compressor cap is disconnected. - Foreign materials are in the pipe. 	<ul style="list-style-type: none"> ■ Heat a clogged evaporator to check it. As soon as the cracking sound starts, the evaporator will begin to freeze. ■ The evaporator does not cool from the beginning (no evidence of moisture attached). The evaporator is the same as before even heat is applied.

TROUBLE DIAGNOSIS

CLAIMS.	CAUSES AND CHECK POINTS.	HOW TO CHECK
<p>3. Poor Cooling</p>	<p>1) Refrigerant Partly leaked. ┌ Weld joint leak. └ Parts leak.</p> <p>2) Poor defrosting capacity.</p> <p style="margin-left: 20px;">┌ Drain path (pipe) clogged. ┌ Inject adiabatics into drain hose. └ Foreign materials penetration. ┌ Adiabatics lump input. └ Damage by a screw or clamp. └ Other foreign materials input. └ Cap drain is not disconnected.</p> <p style="margin-left: 20px;">┌ Defrost heater does not generate heat. ┌ Parts disconnected. ┌ Plate heater ┌ Wire is cut. └ Heating wire. └ Contact point between heating and electric wire. └ Dent by fin evaporator. └ Poor terminal contacts. └ Cord heater ┌ Wire is cut. └ Lead wire. └ Heating wire. └ Contact point between heating and electric wire. └ Heating wire is corroded. └ Water penetration. └ Bad terminal connection.</p>	<p>■ Check visually.</p> <p>■ Check terminal Conduction: OK. No conduction: NG. If wire is not cut, refer to resistance. P=Power V=Voltage R=Resistance</p> $P = \frac{V^2}{R}$ $R = \frac{V^2}{P}$

TROUBLE DIAGNOSIS

CLAIMS.	CAUSES AND CHECK POINTS.	HOW TO CHECK
<p>3. Poor Cooling</p>	<ul style="list-style-type: none"> Residual frost. <ul style="list-style-type: none"> Weak heat from heater. - Sheath Heater - rated. Too short defrosting time. <ul style="list-style-type: none"> Defrost Sensor. <ul style="list-style-type: none"> - Faulty characteristics. Seat-D (missing, location, thickness). Structural fault. <ul style="list-style-type: none"> Gasket gap. Air inflow through the fan motor. Bad insulation of case door. No automatic defrosting. Defrost does not return. 3) Cooling air leak. <ul style="list-style-type: none"> Bad gasket adhesion <ul style="list-style-type: none"> Gap. Bad attachment. Contraction. Door sag. <ul style="list-style-type: none"> Bad adhesion. Weak binding force at hinge. 4) No cooling air circulation. <ul style="list-style-type: none"> Faulty fan motor. <ul style="list-style-type: none"> Fan motor. <ul style="list-style-type: none"> Self locked. Wire is cut. Bad terminal contact. Door switch. <ul style="list-style-type: none"> Faults. <ul style="list-style-type: none"> Contact distance. Button pressure. Melted contact. Contact. Refrigerator and freezer switch reversed. Button is not pressed. <ul style="list-style-type: none"> Poor door attachment. Door liner (dimension). Contraction inner liner. Misalignment. Bad terminal connection. Adiabatics liquid leak. 	<p>■ Check the fan motor conduction: OK. No conduction: NG.</p>

TROUBLE DIAGNOSIS

CLAIMS.	CAUSES AND CHECK POINTS.	HOW TO CHECK
<p>3. Poor Cooling</p>	<p>4) No cooling air circulation.</p> <ul style="list-style-type: none"> — Faulty fan motor. — Fan is constrained. <ul style="list-style-type: none"> — Fan shroud contact. - Clearance. — Damping evaporator contact. — Accumulated residual frost. — Small cooling air discharge. <ul style="list-style-type: none"> — Insufficient motor RPM <ul style="list-style-type: none"> — Fan overload. - Fan misuse. — Bad low temperature RPM characteristics. — Rated power misuse. — Low voltage. — Faulty fan. <ul style="list-style-type: none"> — Fan misuse. — Bad shape. — Loose connection. - Not tightly connected. — Insert depth. — Shroud. — Bent. — Ice and foreign materials on rotating parts. <p>5) Compressor capacity. <ul style="list-style-type: none"> — Rating misuse. — Small capacity. — Low voltage. </p> <p>6) Refrigerant too much or too little. <ul style="list-style-type: none"> — Malfunction of charging cylinder. — Wrong setting of refrigerant. — Insufficient compressor. - Faulty compressor. </p> <p>7) Continuous operation <ul style="list-style-type: none"> - No contact of temperature controller. - Foreign materials. </p> <p>8) Damper opens continuously. <ul style="list-style-type: none"> — Foreign materials jammed. <ul style="list-style-type: none"> — Adiabatics liquid dump — The EPS (styrofoam®) drip tray has sediment in it. — A screw or other foreign material has fallen into the drip tray or damper. — Failed sensor. - Position of sensor. — Characteristics of damper. <ul style="list-style-type: none"> — Bad characteristics of its own temperatue. — Parts misuse. — Charge of temperature - Impact. characteristics. </p> <p>9) Food storing place. - Near the outlet of cooling air.</p>	<p>■ Check visually after disassembly.</p> <p>■ Check visually after disassembly.</p>

TROUBLE DIAGNOSIS

CLAIMS.	CAUSES AND CHECK POINTS.	HOW TO CHECK
<p>4. Warm refrigerator compartment temperature.</p> <p>5. No automatic operation. (faulty contacts)</p>	<p>1) Clogged cooling path.</p> <ul style="list-style-type: none"> └ Adiabatics liquid leak ?. └ Foreign materials. — Adiabatics dump liquid <p>2) Food storage.</p> <ul style="list-style-type: none"> └ Store hot food. └ Store too much at once. └ Door open. └ Packages block air flow. <p>1) Faulty temperature sensor in freezer or refrigerator compartment.</p> <ul style="list-style-type: none"> └ Faulty contact. └ Faulty temperature characteristics. <p>2) Refrigeration load is too much.</p> <ul style="list-style-type: none"> └ Food. <ul style="list-style-type: none"> └ Too much food. └ Hot food. └ Frequent opening and closing. └ Cool air leak. └ Poor door close. — Partly opens. <p>3) Poor insulation.</p> <p>4) Bad radiation.</p> <ul style="list-style-type: none"> └ High ambient temperature. └ Insufficient space around refrigertor. <p>5) Refrigerant leak.</p> <p>6) Inadequate of refrigerant.</p> <p>7) Weak compressor discharging power.</p> <ul style="list-style-type: none"> └ Different rating. └ Small capacity. <p>8) Fan does not work.</p> <p>9) Button is set at strong.</p>	<p>■ Inspect parts measurements and check visually.</p>
<p>6. Condensation and ice formation.</p>	<p>1) Ice in freeezer compartment.</p> <ul style="list-style-type: none"> └ External air inflow. — Bushing installed incorrectly. └ Door opens but not closes. <ul style="list-style-type: none"> └ Weak door closing power. └ Stopper malfunction. └ Door sag. └ Food hinders door closing. └ Gap around gasket. — Contraction, distortion, loose, door twisted, corner not fully inserted. └ Food vapor. — Storing hot food. — Unsealed food. <p>2) Condensation in the refrigerator compartment.</p> <ul style="list-style-type: none"> └ Door opens but not closes. <ul style="list-style-type: none"> └ Insufficient closing. └ Door sag. └ Food hinders door closing. └ Gasket gap. <p>3) Condensation on liner foam.</p> <ul style="list-style-type: none"> └ Cool air leak and transmitted. <ul style="list-style-type: none"> └ Not fully filled. <ul style="list-style-type: none"> └ Top table part. └ Out plate Ref/Lower part. └ Flange gap. — Not sealed. └ Gasket gap. 	

TROUBLE DIAGNOSIS

CLAIMS.	CAUSES AND CHECK POINTS.	HOW TO CHECK
<p>6. Condensation and ice formation.</p>	<p>4) Condensation on door.</p> <ul style="list-style-type: none"> Condensation on the duct door. - Duct door heater is cut. Condensation on the dispense recess. <ul style="list-style-type: none"> Recess Heater is cut. Duct door is open. / Foreign material clogging. Condensation on the door surface. <ul style="list-style-type: none"> Not fully filled. <ul style="list-style-type: none"> Surface. } Liquid shortage. Corner. } Liquid leak. Adiabatics liquid contraction. Condensation on the gasket surface. <ul style="list-style-type: none"> Bad adhesion. - Door liner shape mismatch. Corner. <ul style="list-style-type: none"> Too much notch. Broken. Home Bar heater is cut. <p>5) Water on the floor.</p> <ul style="list-style-type: none"> Condensation in the refrigerator compartment. Defrosted water overflows. — Clogged discharging hose. Discharging hose — Evaporation tray located at wrong place. location. Tray drip. <ul style="list-style-type: none"> Damaged. Breaks, holes. Small Capacity. Position of drain. 	
<p>7. Sounds</p>	<p>1) Compressor compartment operating sounds.</p> <ul style="list-style-type: none"> Compressor sound inserted. <ul style="list-style-type: none"> Sound from machine itself. Sound from vibration. <ul style="list-style-type: none"> Restrainer. Bushing seat. <ul style="list-style-type: none"> Too hard. Distorted. Aged. Burnt. Stopper. — Bad Stopper assembly. <ul style="list-style-type: none"> Not fit (inner diameter of stopper). Tilted. Not Compressor base not connected. Bad welding compressor stand(fallen). Foreign materials in the compressor compartment. OLP sound. — Chattering sound. Capacitor noise. — Insulation paper vibration. Pipe sound. <ul style="list-style-type: none"> Pipe contacts each other. — Narrow interval. No vibration damper. — Damping Bushing. Capillary tube unattached. 	

TROUBLE DIAGNOSIS

CLAIMS.	CAUSES AND CHECK POINTS.	HOW TO CHECK
7. Sounds	<p>1) Compressor compartment operating sounds.</p> <ul style="list-style-type: none"> Transformer sound. — Bad connection. — Correct screw connection. Drip tray vibration sound. <ul style="list-style-type: none"> Bad assembly. Distortion. Foreign materials inside. Back cover machine sound. <ul style="list-style-type: none"> Bad connection. Partly damaged. Condenser drain sound. <ul style="list-style-type: none"> Not connected. Bad pipe caulking. <p>2) Freezer compartment sounds.</p> <ul style="list-style-type: none"> Fan motor sound. <ul style="list-style-type: none"> Normal operating sound. Vibration sound. <ul style="list-style-type: none"> Old, dried, or cracked bushing Bad torque for assembling motor bracket. Sounds from fan contact. <ul style="list-style-type: none"> Fan guide contact. Shroud burr contact. Damping evaporator contact. Residual frost contact. <ul style="list-style-type: none"> Damaged heater cord. Narrow evaporator interval. Unbalance fan sounds. <ul style="list-style-type: none"> Unbalance. <ul style="list-style-type: none"> Surface machining conditions. Fan distortion. Misshappen. Burr. Ice on the fan. — Air intake (opposite to motor bushing assembly.) Motor shaft contact sounds. <ul style="list-style-type: none"> Supporter disorted. Tilted during motor assembly. Resonance. Evaporator noise. <ul style="list-style-type: none"> Evaporator pipe contact. — No damping evaporator. Sound from refrigerant. — Stainless steel pipe shape in accumulator. Sound from fin evaporator and pipe during expansion and contraction. <p>3) Bowls and bottles make contact on top shelf.</p> <p>4) Refrigerator roof contact.</p> <p>5) Refrigerator side contact.</p> <p>6) Insufficient lubricants on door hinge.</p>	

TROUBLE DIAGNOSIS

CLAIMS.	CAUSES AND CHECK POINTS.	HOW TO CHECK
<p>8. Faulty lamp (freezer and refrigerator compartment).</p>	<p>1) Lamp problem. — Filament blows out. — Glass is broken.</p> <p>2) Bad lamp assembly. — Not inserted. — Loosened by vibration.</p> <p>3) Bad lamp socket.</p> <p>— Disconnection. — Bad soldering. — Bad rivet contact.</p> <p>— Short. — Water penetration. — Low water level in tray.</p> <p>— Bad elasticity of contact.</p> <p>— Bad contact (corrosion).</p> <p>4) Door switch. — Defective. — Refrigerator and freezer switches are reversed. — Travel distance. — Bad connection. — Bad terminal contact. — Adiabatics liquid leak.</p>	
<p>9. Faulty internal voltage (short).</p>	<p>1) Lead wire is damaged.</p> <p>— Wire damage when assembling PTC Cover. — Outlet burr in the bottom plate. — Pressed by cord heater. lead wire, evaporator pipe.</p> <p>2) Exposed terminal.</p> <p>— Compressor Compartment terminal. - Touching other components. — Freezer compartment terminal. - Touching evaporator pipe.</p> <p>3) Faulty parts.</p> <p>— Transformer. — Coil contacts cover. — Welded terminal parts contact cover.</p> <p>— Compressor. — Bad coil insulation.</p> <p>— Plate heater.</p> <p>— Melting fuse. — Sealing is broken. — Moisture penetration.</p> <p>— Cord heater. — Pipe damaged. — Moisture penetration. — Bad sealing.</p> <p>— Sheath heater.</p>	<p>■ Connect conduction and non-conduction parts and check with tester. Conduction: NG. Resistance∞: OK.</p>

TROUBLE DIAGNOSIS

CLAIMS.	CAUSES AND CHECK POINTS.	HOW TO CHECK
<p>10. Structure, appearance, and others.</p>	<p>1) Door foam.</p> <ul style="list-style-type: none"> Sag. <ul style="list-style-type: none"> Hinge loose <ul style="list-style-type: none"> Bolt is loosened during transportation. Not tightly fastened. Fastener worn or damaged. Weak gasket adhesion. <ul style="list-style-type: none"> Gasket sealing surface defective. Fixed tape. <ul style="list-style-type: none"> Not properly attached. Noise during operation. <ul style="list-style-type: none"> Hinge interference. <ul style="list-style-type: none"> Bigger door foam. Hinge-Pin tilted-Poor flatness. No washer. No grease. Malfunction. <ul style="list-style-type: none"> Not closed Interference between door liner and inner liner. Refrigerator compartment is opened when freezer compartment is closed (faulty stopper). <ul style="list-style-type: none"> Stopper worn out. Bad freezer compartment door assembly. No stopper. <p>2) Odor.</p> <ul style="list-style-type: none"> Temperature of refrigerator compartment. <ul style="list-style-type: none"> High. <ul style="list-style-type: none"> Faulty damper control. Button is set at weak. Door is open (something in the way). Deodorizer. <ul style="list-style-type: none"> No deodorizer. Poor capacity. Food Storage. <ul style="list-style-type: none"> Seal condition. Storage of fragrant foods. Long term storage. Others. <ul style="list-style-type: none"> Odors from cleaners or items which should not be stored in a refrigerator. 	

TROUBLE DIAGNOSIS

2. Faults

2-1. Power

Problems	Causes	Checks	Measures	Remarks
No power on outlet.	<ul style="list-style-type: none"> - Power cord cut. - Faulty connector insertion. - Faulty connection between plug and adapter. 	<ul style="list-style-type: none"> - Check the voltage with tester. - Check visually. - Check visually. 	<ul style="list-style-type: none"> - Replace the components. - Reconnect the connecting parts. - Reconnect the connecting parts. 	
Fuse blows out.	<ul style="list-style-type: none"> - Short circuit by wrong connection. - Low voltage products are connected to high voltage. - Short caused by vermin. - Electricity leakage. - High voltage. - Short circuit of components (tracking due to moisture and dust penetration). 	<ul style="list-style-type: none"> - Check the fuse with tester or visually. - Check the input volt are with tester (between power cord and products). - Check the resistance of power cord with tester (if it is 0Ω, it is shorted). 	<ul style="list-style-type: none"> - Find and remove the cause of problem (ex. short, high voltage, low voltage). - Replace with rated fuse. 	<ul style="list-style-type: none"> - Replace with rated fuse after confirming its specification. ■ If fuse blows out frequently, confirm the cause and repair.

2-2. Compressor

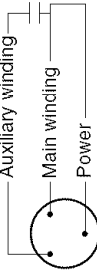
Problems	Causes	Checks	Measures	Remarks
Compressor does not operate.	<ul style="list-style-type: none"> - Faulty PTC. - Compressor is locked up. 	<ul style="list-style-type: none"> - Check the resistance. Value:∞ is defective. - If compressor assembly parts are normal (capacitor, PTC, OLP), apply power directly to the compressor to force operation. 	<ul style="list-style-type: none"> - If resistance is infinite, replace it with new one. - If it is not infinite, it is normal. - Check other parts. - During forced operation: - Operates: Check other parts. - Does not operate operate: Replace the frozen compressor with new one, weld, evacuate, and recharge refrigerant. 	
		 <p>OLP It starts as soon as it is contacted.</p>	<ul style="list-style-type: none"> • Refer to weld repair procedures. 	

TROUBLE DIAGNOSIS

2-3. Temperature

Problems	Causes	Checks	Measures	Remarks
High temperature in the freezer compartment.	Poor cool air circulation due to faulty fan motor.	<ul style="list-style-type: none"> - Lock — Check resistance with a tester. 0Ω: short. ∞Ω: cut. - Rotate rotor manually and check rotation. - Wire is cut. - Check for bad terminal connection. - Fan constraint. – Fan shroud contact: Confirm visually. – Fan icing: Confirm visually. 	<ul style="list-style-type: none"> - Replace fan motor. - Reconnect and reinsert. - Maintain clearance and remove ice (Repair and/or replace shroud if fan is constrained by shroud deformation). 	
	Faulty fan motor due to faulty door switch operation.	<ul style="list-style-type: none"> - Iced button (faulty) operation: Press button to check - Faulty button pressure and contact: Press button to check operation. - Door cannot press door switch button: Check visually. 	<ul style="list-style-type: none"> - Confirm icing causes and repair. - Replace door switch. - Door sag: fix door. - Door liner bent: replace door or attach sheets. 	
	Poor heat exchange in compressor area.	<ul style="list-style-type: none"> - Check the clearance between the refrigerator and wall minimum of 4 " (50 mm). - Check dust on the grill in compressor compartment. - Check dust on the condenser coils. 	<ul style="list-style-type: none"> - Keep clearance between refrigerator and walls minimum of 4 " (50 mm). - Remove dust and contaminants from grill for easy heat radiation. - Remove the dust with vacuum cleaner from the coils condenser while the refrigerator is off. 	<ul style="list-style-type: none"> - The fan may be broken of damaged if cleaned while the refrigerator is running.

TROUBLE DIAGNOSIS

2-4. Cooling

Problems	Causes	Checks	Measures	Remarks
High temperature in the freezer compartment.	Refrigerant leak.	<p><u>Check sequence</u></p> <ol style="list-style-type: none"> 1. Check the welded parts of the drier inlet and outlet and drier auxiliary in the compressor compartment (high pressure side). 2. Check the end of compressor sealing pipe (low pressure side). 3. Check silver soldered parts. 4. Check bending area of wire condenser pipe in compressor compartment (cracks can happen during bending). 5. Check other parts (compressor compartment and evaporators in freezer compartment). 	Weld the leaking part, recharge the refrigerant.	Drier must be replaced.
	Shortage of refrigerant.	<p>Check frost formation on the surface of evaporator in the freezer compartment.</p> <ul style="list-style-type: none"> - If the frost forms evenly on the surface, it is OK. - If it does not, it is not good. 	<ul style="list-style-type: none"> - Find out the leaking area, repair, evacuate, and recharge the refrigerant. - No leaking, remove the remaining refrigerant, and recharge new refrigerant. 	Drier must be replaced.

TROUBLE DIAGNOSIS

Problems	Causes	Checks	Measures	Remarks
High temperature in the freezer compartment.	Cycle pipe is clogged.	<p>Check sequence.</p> <ol style="list-style-type: none"> 1. Check temperature of condenser manually. If it is warm, OK. If it is not, compressor discharging joints might be clogged. 2. Manually check whether hot line pipe is warm. If it is warm, OK. If it is not, condenser outlet weld joints might be clogged. 	<ul style="list-style-type: none"> - Maybe evacuate should be the first step here. If the servicer puts a torch to a charged system, the joint will explode and spray refrigerant on him. Also, if oil is forced out, it could create a fire or safety hazard. - If it's warm, OK. If it's not, condenser discharging line weld joints might be clogged. <p>Discharge the system and recover the refrigerant. Then use a torch to disconnect unbrazed piping to repair the obstruction. Repair, evacuate the system, and recharge it before testing.</p>	Drier must be replaced.
	Leak at loop pipe weld joint (discharge) in compressor.	<p>Check sequence.</p> <ol style="list-style-type: none"> 1. Manually check whether condenser is warm, it is not warm and the frost forms partly on the evaporator in the freezer compartment. 	<p>Replace the compressor, weld, evacuate, and recharge refrigerant.</p>	Drier must be replaced.
	Faulty cooling fan in the compressor compartment.	<p>Check sequence.</p> <ol style="list-style-type: none"> 1. Check cooling fan operation. 2. Check that cooling fan is disconnected from the motor. 	<ul style="list-style-type: none"> - Replace if motor does not operate. - If fan is disconnected, check fan damage and reassemble it. <p>■ Refer to fan motor disassembly and assembly sequence.</p>	

TROUBLE DIAGNOSIS

2-5. Defrosting failure

Problems	Causes	Checks	Measures	Remarks
No defrosting.	<p>Heater does not generate heat as the heating wire is cut or the circuit is shorted.</p> <p>1) Heating wire is damaged when inserting into the evaporator.</p> <p>2) Lead wire of heater is cut.</p> <p>3) Heating wire at lead wire contacts is cut.</p>	<p>1. Check the resistance of heater. 0Ω: Short. ∞Ω: Cut. Tens to thousands Ω: OK.</p> <p>2. Check the resistance between housing terminal and heater surface. 0Ω: Short. ∞Ω: Cut. Tens to thousands Ω: Short.</p>	<p>Heating wire is short and wire is cut.</p> <p>• Parts replacement: Refer to parts explanations.</p>	<p>Seal the lead wire with insulation tape and heat shrink tube if the cut lead wire is accessible to repair.</p>
Suction tube and discharge orifice:	<p>1. Impurities.</p> <p>2. Ice.</p>	<p>1. Confirm foreign materials. In case of ice, insert the copper line through the hole to check.</p> <p>2. Put hot water into the drain (check drains outside).</p>	<p>1) Push out impurities by inserting copper wire. (Turn off more than 3 hours and pour in hot water if frost is severe.)</p> <p>2) Put in hot water to melt down frost.</p> <p>3) Check the water outlet.</p> <p>4) Push the heater plate to suction duct manually and assemble the disconnected parts.</p>	
Gap between Suction duct and Heater plate (Ice in the gap).		<p>1. Confirm in the Suction duct.</p>	<p>1) Turn off the power, confirm impurities and ice in the gap, and supply hot water until the ice in the gap melts down.</p> <p>2) Push the Heater plate to drain bottom with hand and assemble the disconnected parts.</p>	
Wrong heater rating (or wrong assembly).		<p>1. Check heater label.</p> <p>2. Confirm the capacity after substituting the resistance value into the formula.</p> $P = \frac{V^2}{R}$ <p>(V: Rated voltage of user country) (R: Resistance of tester[Ω])</p> <p>Compare P and label capacity. Tolerance: ±7%</p>	<p>Faults: Replace.</p> <p>- How to replace : Refer to main parts.</p>	

TROUBLE DIAGNOSIS

Problems	Causes	Checks	Measures	Remarks
No defrosting	<p>Melting fuse blows.</p> <p>1) Lead wire is cut.</p> <p>2) Bad soldering.</p> <p>Ice in the Suction duct.</p> <p>1) Icing by foreign materials in the duct.</p> <p>2) Icing by cool air inflow through the gap of heater plate.</p> <p>3) Icing by the gap of heater plate.</p>	<p>- Check melting fuse with tester. - If 0Ω: OK. If ∞Ω: wire is cut.</p> <p>1. Check the inner duct with mirror.</p> <p>2. Check by inserting soft copper wire into the duct (soft and thin copper not to impair heating wire).</p>	<p>Faulty parts: parts replacement.</p> <p>- Check wire color when measuring resistance with a tester.</p> <p>1) Turn power off.</p> <p>2) Raise the front side (door side), support the front side legs, and let the ice melt naturally. (If power is on, melt the frost by forced defrosting.)</p> <p>3) Reassemble the heater plate.</p>	
	<p>Bad cool air inflow and discharge, and bad defrosting due to faulty contact and insertion (bad connector insertion into housing of heater, melting, fuse, and motor fan).</p>	<p>1. Turn on power, open or close the door, check that motor fan operates (If it operates, motor fan is OK).</p> <p>2. Disconnect parts in the refrigerator compartment, check the connection around the housing visually, defrost, and confirm heat generation on the heater. Do not put hands on the sheath heater.</p> <p>3. Check the parts which have faults described in 1 & 2 (mechanical model: disconnect thermostat from the assembly).</p>	<p>1) Check the faulty connector of housing and reassemble wrongly assembled parts.</p> <p>2) If the parts are damaged, remove the parts and replace it with a new one.</p>	

TROUBLE DIAGNOSIS

2-6. Icing

Problems	Causes	Checks	Measures	Remarks
Icing in the refrigerator compartment. - Damper icing. - Pipe icing. - Discharging pipe icing.	1) Bad circulation of cool air. - Clogged intake port in the refrigerator compartment. - Sealing is not good. - Too much food is stored and clogs the discharge port. - Bad defrosting.	- Check if food is stored properly (check if discharge and intake port are clogged). - Check icing on the surface of baffle and cool air path (pipe) after dissembling the container box. - Check icing at intake ports of freezer and refrigerator compartment.	- Be acquainted with how to use. - Sealing on connecting parts. - Check the damper and replace it if it has defects. - Check defrost. (After forced defrosting, check ice in the evaporator and pipes.)	- Check the defrost related parts if problem is caused by faulty defrosting.
	2) Faulty door or refrigerator compartment. - Faulty gasket. - Faulty assembly.	- Check gasket attached conditions. - Check door assembly conditions.	- Correct the gasket attachment conditions and replace it. - Door assembly and replacement.	- Replacement should be done when it cannot be repaired.
	3) Overcooling in the refrigerator compartment. - Faulty damper in the refrigerator compartment. - Faulty MICOM (faulty sensor)	- Check if refrigerator compartment is overcooled (when button pressed on weak). - Check parts are faulty.	- Replace faulty parts.	
	4) Bad defrosting - Heater wire is cut. - Defective defrost sensor. - Defrosting cycle.	- Check for frost on the evaporator after dissembling shroud and fan grille. - Check for ice on intake port of freezer and refrigerator compartment.	- Check parts related to defrosting. - Check defrosting. (Check ice on the evaporator and pipe.)	- Moisture does not freeze on the evaporator but can be sucked into the refrigerator, where it condenses and freezes. This interferes with cold air circulation and sublimation of the ice.
	5) Customers are not familiar with this machine. - Door opens. - High temperature, high moisture, and high load.	- Check if food interferes with door closing. - Check for ice on the ceilings.	- Read the manual and become familiar with the operation of the product.	

TROUBLE DIAGNOSIS

Problems	Causes	Checks	Measures	Remarks
Ice in the freezer compartment. - Surface of fan grille. - Wall of freezer compartment. - Cool air discharging port. - Basket(rack) area.	1) Bad cooling air circulation. - Intake port is clogged in the freezer compartment. - Discharging port is Clogged. - Too much food is stored. - Bad defrosting.	- Check food storage conditions visually. (Check clogging at intake and discharging port of cooling air.) - Check food occupation ratio in volume (Less than 75%). - Check frost on the evaporator after dissembling shroud and fan grille. - Check icing at intake port of refrigerator compartment.	- Be acquainted with how to use. - Check defrost (Check ice on the evaporator and pipes after forced defrosting).	- Check the parts related to defrosting if the problem is caused by the faulty defrosting.
- Food surface. - Icing in the shute.	2) Bad freezer compartment door - Faulty gasket - Faulty assembly	- Check gasket attachment conditions. - Check door assembly conditions.	- Correct the gasket attachment conditions and replace it. - Door assembly and replacement.	- Replace when it can not be repaired.
	3) Over freezing in the freezer compartment. - Faulty MICOM.	- Refrigerator operates pull down. (Check if it is operated intermittently) - The Temperature of freezer compartment is satisfactory, but over freezing happens in the refrigerator compartment even though the notch is set at weak .	- Replace defective parts.	
	4) Bad defrosting. - Heater wire is cut. - Faulty defrost sensor. - Defrosting cycle	- Check frost on the evaporator after dissembling shroud and grille. - Check ice on the intake port in the refrigerator compartment.	- Check parts related to defrosting. - Check defrosting. Check ice on the evaporator and pipes after forced defrosting.	
	5) User is not familiar with how to use. - Door opens. - High moisture food water is stored.	- Check food holds door open. - Check ice on the ice tray.	- Be acquainted with how to use.	

TROUBLE DIAGNOSIS

2-7. Sound

Problems	Causes	Checks	Measures	Remarks
Hiss sound	1. Loud sound of compressor operation.	1.1 Check the level of the refrigerator. 1.2 Check the bushing seat conditions (sagging and aging).	1) Maintain horizontal level. 2) Replace bushing and seat if they are sagged and aged. 3) Touch the piping at various place along its route. Install a damper at the point where your touch reduces the noise. 4) Avoid pipe interference. 5) Replace defective fan and fan motor. 6) Adjust fan to be in the center of the fan guide. 7) Leave a clearance between interfering parts and seal gaps in the structures. 8) Reassemble the parts which make sound. 9) Leave a clearance if evaporator pipes and suction pipe touch freezer shroud.	
	2. Pipes resonate sound which is connected to the compressor.	2.1 Check the level of pipes connected to the compressor and their interference. 2.2 Check bushing inserting conditions in pipes. 2.3 Touch pipes with hands or screw -driver (check the change of sound).		
	3. Fan operation sound in the freezer compartment.	3.1 Check fan insertion depth and blade damage. 3.2 Check the interference with structures. 3.3 Check fan motor. 3.4 Check fan motor bushing insertion and aging conditions.		
	4. Fan operation sound in the compressor compartment.	4.1 Same as fan confirmation in the refrigerator. 4.2 Check the drip tray support installation. 4.3 Check the screw fastening conditions at condenser and drip tray.		

TROUBLE DIAGNOSIS

Problems	Causes	Checks	Measures	Remarks
<p>Vibration sound. Clack.</p>	<ol style="list-style-type: none"> 1. Vibration of shelves and foods in the refrigerator. 2. Pipes interference and capillary tube touching in the compressor compartment. 3. Compressor stopper vibration. 4. Moving wheel vibration. 5. Other structure and parts vibration. 	<ol style="list-style-type: none"> 1-1. Remove and replace the shelves in the refrigerator 1-2. Check light food and container on the shelves. 2-1. Touch pipes in the compressor compartment with hands. 2-2. Check capillary tube touches cover back. 3-1. Check compressor stopper vibration. 4-1. Check vibration of front and rear moving wheels. 5-1. Touch other structures and parts. 	<ol style="list-style-type: none"> 1) Reassemble the vibrating parts and insert foam or cushion where vibration is severe. 2) Leave a clearance where parts interfere with each other. 3) Reduce vibration with bushing and restrainer if it is severe. (especially compressor and pipe). 4) Replace compressor stopper if it vibrates severely. 	
<p>Irregular sound. Click.</p>	<ol style="list-style-type: none"> 1. It is caused by heat expansion and contraction of evaporator, shelves, and pipes in the refrigerator. 	<ol style="list-style-type: none"> 1-1 Check time and place of sound sources. 	<ol style="list-style-type: none"> 1) Explain the principles of refrigeration and that the temperature difference between operation and defrosting can make sounds. 2) If evaporator pipe contacts with other structures, leave a clearance between them (freezer shroud or inner case). 	

TROUBLE DIAGNOSIS

Problems	Causes	Checks	Measures	Remarks
Sound Popping	It happens when refrigerant expands at the end of capillary tube.	<ul style="list-style-type: none"> - Check the sound of refrigerant at the initial installation. - Check the sound when the refrigerator starts operation after forced defrosting. - Check the restrainer attachment conditions on the evaporator and capillary tube weld joints. 	<ul style="list-style-type: none"> - Check the restrainer attached on the evaporator and capillary tube weld joints and attach another restrainer. - If it is continuous and severe, insert capillary tube again (depth 15±3mm) - Fasten the capillary tube to suction pipes or detach in the compressor compartment. - Explain the principles of freezing cycles. 	
Water boiling or flowing sound.	It happens when refrigerant passes orifice in accumulator internal pipes by the pressure difference between condenser and evaporator.	<ul style="list-style-type: none"> - Check the sound when compressor is turned on. - Check the sound when compressor is turned off. 	<ul style="list-style-type: none"> - Explain the principles of freezing cycles and refrigerant flowing phenomenon by internal pressure difference. - If sound is severe, wrap the accumulator with foam and restrainer. 	
Sound of whistle when door closes.	When door closes, the internal pressure of the refrigerator decreases sharply below atmosphere and sucks air into the refrigerator, making the whistle sound.	<ul style="list-style-type: none"> - Check the sound by opening and closing the refrigerator or freezer doors. 	<ul style="list-style-type: none"> - Broaden the cap of discharge hose for defrosting in the compressor compartment. - Seal the gap with sealant between out and inner cases of hinge in door. 	

TROUBLE DIAGNOSIS

2-8. Odor

Problems	Causes	Checks	Measures	Remarks
Food Odor.	Food (garlic, kimchi, etc)	<ul style="list-style-type: none"> - Check the food is not wrapped. - Check the shelves or inner wall are stained with food juice. - Be sure food is securely covered with plastic wrap. - Check food cleanliness. 	<ul style="list-style-type: none"> - Dry the deodorizer in a sunny place with adequate ventilation. - Store the food in the closed container instead of vinyl wraps. - Clean the refrigerator and set button at strong. 	
Plastic Odor.	Odors of mixed food and plastic odors.	<ul style="list-style-type: none"> - Check wet food is wrapped with plastic bowl and bag. - It happens in the new refrigerator. 	<ul style="list-style-type: none"> - Clean the refrigerator. - Persuade customers not to use plastic bag or wraps with wet food or odorous foods. 	
Odor from the deodorizer.	Odor from the old deodorizer.	<ul style="list-style-type: none"> - Check the deodorizer odors. 	<ul style="list-style-type: none"> - Rinse the deodorizer under running water and let it air dry in a sunny place. - Remove and replace the deodorants. 	*Deodorizer is optional on some models.

TROUBLE DIAGNOSIS

2-9. MICOM

Problems	Symptom	Causes		Checks	Measures	Remarks
Bad PCB electric power.	All display LCD are off.	Bad connection between Main PCB and display circuit.	Bad connector connection from main PCB to display PCB.	Visual check on connector connection.	Reconnect connector.	
		Defective PCB transformer.	PCB transformer winding is cut. PCB transformer temperature fuse is burnt out.	Check resistance of PCB transformer input and output terminals with a tester. (If resistance is infinity, trans winding is cut).	Replace PCB transformer or PCB.	Applicable to model without dispenser.
Abnormal display LCD operation	Defective LCD.	Defective PCB electric circuit parts.	Defective regulator IC (7812, 7805).	Check voltage at input/output terminals.	Replace regulator.	Refer to electric circuit in circuit explanation.
			PCB electric terminal fuse is burned out.	Check fuse in PCB electric terminal with a tester.	Replace PCB fuse.	
			STR Parts are damaged.	Check if STR No. 2 and 3 pins are cut when power is off.	Replace parts.	Applicable to model with dispenser.
		Bad connection between Main PCB and display circuit.	Lead Wire connecting main PCB and display PCB is cut or connector terminal connection is bad.	Check Lead Wire terminals connecting Main PCB and display PCB with a tester.	Reconnect Lead Wire and directly connect defective contact terminal to Lead Wire.	
			Defective LCD.	Check if all LCD are on when Main PCB Test switch is pressed (or when both freezer key and power freezer key are pressed at the same time for more than one second.)	Replace display PCB.	Refer to display circuit in circuit explanation.

TROUBLE DIAGNOSIS

Problems	Symptom	Causes		Checks	Measures	Remarks
Bad cooling.	Freezer temperature is high.	Compressor does not start.	Compressor Lead Wire is cut.	Check compressor Lead Wire with a tester.	Reconnect Lead Wire.	
			Defective compressor driving relay.	Measure voltage at PCB CON2 (3 & 9) after pressing main PCB test switch once. It is OK if voltage is normal.	Replace relay RY1 and RY2 or PCB.	Refer to load driving circuit in circuit explanation.
		Defective freezer sensor.	Defective Freezer sensor parts.	Check resistance of freezer sensor with a tester.	Replace freezer sensor.	Refer to resistance characteristics table of sensor in circuit. Refer to tables on pages 39~42
			The wrong sensor has been installed. Order by model number and part number.	Confirm the color of sensor in circuits (main PCB sensor housing).	Repair main PCB sensor housing	explanation.
Defective freezer fan motor.	Fan motor lead wire is cut.	Fan motor lead wire is cut.	Check fan motor lead wire with a tester.	Reconnect lead wire.		
		<ul style="list-style-type: none"> Defective door switch (freezer, refrigerator, home bar). Defective fan motor. Defective fan motor driving relay. 	Measure the voltage between PCB power blue line and fan motor after pressing test switch of Main PCB. If the voltage is normal, it is OK.	<ul style="list-style-type: none"> Replace door switch (freezer, refrigerator, and home bar). Replace fan motor. Replace relay RY5 & RY6 or PCB. 	Refer to load driving circuits in circuit explanation.	
	Faulty defrost.		Refer to faulty defrost items in trouble diagnosis functions.			Refer to trouble diagnosis function.

TROUBLE DIAGNOSIS

Problems	Symptom	Causes	Checks	Measures	Remarks		
Bad cooling	Wrong Refrigerator temperature.	Defective Step Motor Damper.	Check Step Motor damper motor and reed switch and lead wire are cut. Check Step Motor damper part.	Check if Step Motor damper motor and reed switch lead wire are cut with a tester. Refer to Step Motor damper in parts repair guide.	Reconnect lead wire.		
			Check Step Motor damper Motor driving relay in PCB.	Refer to Step Motor damper in parts repair guide.	Replace Step Motor damper or refrigerator control box Assembly.	Refer to single motor damper driving circuits in circuit explanation.	
		Foreign materials in Step Motor damper baffles.	Check Step Motor damper baffle visually.	Remove foreign materials.			
			Ice formation on Step Motor damper baffles.	Check if Step Motor damper Heater wire is cut with a tester.	Replace Step Motor damper or refrigerator control Box Assembly.		
		Defective refrigerator sensor	Defective refrigerator sensor parts.	Check the resistance of refrigerator sensor with a tester.	Replace refrigerator sensor.	Refer to sensor resistance characteristic table in circuit explanation.	
			Refrigerator sensor is substituted for other sensor.	Check the sensor color in the circuit. (Main PCB sensor housing.)	Repair main PCB sensor housing.		
			Defective refrigerator sensor assembly condition.	Check if refrigerator sensor is not attached at cover sensor but inner case visually.	Re-attach again the refrigerator sensor.		

TROUBLE DIAGNOSIS

Problems	Symptom	Causes	Checks	Measures	Remarks
Bad defrost.	Defrost is not working.	Defrost lead wire is cut.	Check if defrost lead wire is cut with a tester.	Reconnect Lead Wire.	
		Defective defrost driving relay.	Check the voltage of CON2 (1 and 7) with a tester after pressing main PCB test switch twice. If the voltage is normal then it is OK.	Replace relay (RY 7 and RY 3) or PCB.	Refer to load driving conditions check in circuit explanation.
		Defective defrost sensor parts.	Check the resistance of defrost sensor with a tester.	Replace defrost sensor.	Refer to sensor resistance characteristic table of circuit explanation.
Defective buzzer	Buzzer continuously rings or door opening alarm does not work.	Defective connecting lead wire from main PCB to door switch.	Check lead wire related to door switch with a tester.	Repair lead wire.	
		Defective door switch parts.	Refer to door switch in parts repair guide.	Replace door switch.	
Defective display button	Buzzer does not sound and buttons do not operate.	Key input wire is cut or bad connector terminal contact in main PCB and display PCB connecting lead wire.	Check input wire with a tester.	Reconnect lead wire and replace or directly connect bad contact terminal to lead wire.	Refer to display circuit in circuit explanation.
		Key is continuously depressed due to structural interference.	Disassemble frame display and confirm visually.	Adjust or replace interfering structures.	

TROUBLE DIAGNOSIS

Problems	Symptom	Causes	Checks	Measures	Remarks
Defective display button.	Buzzer does not sound and buttons do not operate.	Trouble mode indication.	Check trouble diagnosis function.	Repair troubles	Refer to mode indication in function explanations.
Door Buzzer	Buzzer continuously rings or door opening alarm does not work.	Defective connecting lead wire from main PCB to door switch.	Check lead wire associated with door switch.	Repair lead wire.	Check model with dispenser.
		Defective freezer compartment door switch parts.	Refer to door switch in parts repair guide.	Replace Freezer compartment door switch.	
Defective water / ice dispenser.	Ice and water are not dispensed.	Defective connecting lead wire from Main PCB to lever switch.	Check Lead Wire associated with lever switch with a tester.	Repair lead wire.	
		Defective lever switch parts	Refer to door switch in parts repair guide.	Replace lever switch.	
		Defective photo coupler IC parts.	Check voltage change at photo coupler output terminals with lever switch pressed. It is OK if voltage change is between 0V - 5V.	Replace photo coupler IC or PCB.	
		Defective relay associated with ice dispenser (gearing motor, cube, and dispenser solenoid).	Check relay (RY4, RY5, RY12) with a tester.	Replace defective relay.	
		Defective parts associated with ice dispenser (gearing motor, cube, and dispenser solenoid).	Check resistance of parts with a tester.	Replace defective parts.	
		Defective relay associated with water dispenser.	Check relay (RY7) with a tester	Replace defective relay.	
	Defective parts associated with water dispenser.	Check resistance of parts with a tester.	Replace defective parts.		

TROUBLE DIAGNOSIS









3. Cooling Cycle Heavy Repair

3-1. The Heavy Repair Standards for Refrigerator with R134a Refrigerant

NO.	Items	Unit	Standards	Purposes	Remarks	
1	Pipe and piping system opening time.	Min.	Pipe: within 1 hour. Comp: within 10 minutes. Drier: within 20 minutes.	To protect Moisture Penetration.	The opening time should be reduced to a half of the standards during rain and rainy seasons (the penetration of water into the pipe is dangerous).	
2	Welding.	Nitrogen Pressure.	Weld under Nitrogen atmosphere (N ₂ pressure: 0.1~0.2 kg/cm ²)	To protect oxide scale formation.	- Refet to repair note in each part. - R134a refrigerant is more susceptible to leaks than R12 and requires more care during welding. - Do not apply force to pipes before and after welding to protect pipe from cracking.	
3	N ₂ sealed parts.	Confirm N ₂ leak.	Confirm air leaking sounds when removing bushing cap. Sound: usable No sound: not usable	To protect moisture penetration.	- In case of evaporator parts, if it doesn't make noise when removing bushing cap blow dry air or N ₂ gas for more than 1 min use the parts.	
4	Refrigeration Cycle.	Evacuation time	Min.	More than 40 minutes.	To remove moisture.	Note: Only applicable to the model equipped with reverse flow protect plate. Vaccum efficiency can be improved by operating compressor during evacuation. The bushing pipes for R12 refrigerant will be melted when they are used for R134a refrigerant causes of leak.
		Vacuum degree	Torr	Below 0.03(ref)		
		Vacuum	EA	High and low Pressure sides are evacuated at the same time for models above 200ℓ		
		Vacuum piping	EA	Use R134a exclusive manifold.	To protect mixing of mineral and ester oils.	
		Pipe coupler	EA	Use R134a cxclusive.	To protect R12 Refrigerant mixing.	
		Outlet (Socket) Plug		R134a exclusive. R134a exclusive		
5	Refrigerant weighing.	EA	Use R134a exclusively. Weighing allowance: ±5g Note: Winter: -5g Summer: +5g	Do not mix with R12 refrigerant.	- Do not weigh the refrigerant at too hot or too cold an area. (25°C [77°F] is adequate.) - Use copper charging canister Socket:2SV Plug: 2PV R134a Note : Do not burn O-ring (rubber) during welding.	
6	Drier replacement.		-Use R134a exclusively for R134a refrigerator -Replace drier whenever repairing refrigerator cycle piping.	To remove the moisture from pipe.		
7	Leak check.		-Do not use soapy water for check. It may be sucked into the pipe.	Detect refrigerant leak area.	- Check oil leak at refrigerant leak area. Use electronic leak detector if oil leak is not found. - The electronic leak detector is very sensitive to halogen gas in the air. It also can detect R141b in urethane. Please practice, therefore, many times before use.	

TROUBLE DIAGNOSIS

3-2. Summary Of Heavy Repair

Process	Contents	Tools
		
	<ul style="list-style-type: none"> - Cut charging pipe ends and discharge refrigerant from drier and compressor. 	Filter, side cutters
	<ul style="list-style-type: none"> - Use R134a oil and refrigerant for compressor and drier - Confirm N₂ sealing and packing conditions before use. Use good one for welding and assembly. - Weld under nitrogen gas atmosphere. (N₂ gas pressure: 0.1-0.2kg/cm²). - Repair in a clean and dry place. 	Pipe Cutter, Gas welder, N ₂ gas
	<ul style="list-style-type: none"> - Evacuate for more than forty minutes after connecting manifold gauge hose and vacuum pump to high (drier) and low (compressor refrigerant discharging parts) pressure sides. - Evacuation Speed: 113 liters/minute. 	Vacuum pump R134a exclusively, Manifold gauge.
	<ul style="list-style-type: none"> - Weigh and control the allowance of R134a charging canister in a vacuum conditions to be ± 5 g with electronic scales and charge through compressor inlet (Charge while compressor operates). - Weld carefully after pinching off the inlet pipe. 	R134a exclusive charging canister (mass cylinder), refrigerant R134a manifold gauge, electronic scales, pinch-off plier, gas welding machine
	<ul style="list-style-type: none"> - Check leak at weld joints. <ul style="list-style-type: none"> □ Minute leak : Use electronic leak detector □ Big leak : Check visually. Note: Do not use soapy water for check. - Check cooling capacity <ol style="list-style-type: none"> ① Check radiator manually to see if warm. ② Check hot line pipe manually to see if warm. ③ Check frost formation on the whole surface of the evaporator. 	Electronic Leak Detector, Driver (Ruler).
	<ul style="list-style-type: none"> - Remove flux from the silver weld joints with soft brush or wet rag. Flux may be the cause of corrosion and leaks. - Clean R134a exclusive tools and store them in a clean tool box or in their place. 	Copper brush, Rag, Tool box
	<ul style="list-style-type: none"> - Installation should be conducted in accordance with the standard installation procedure. Leave space of more than 5 cm (2 inches) from the wall for compressor compartment cooling fan mounted model. 	

TROUBLE DIAGNOSIS

3-3. Precautions During Heavy Repair

Items	Precautions
1. Use of tools.	1) Use special parts and tools for R134a.
2. Recovery of refrigerant.	<p>1) Continue to recover the refrigerant for more than 5 minutes after turning the refrigerator off.</p> <p>2) Install a piercing type valve on the high pressure line (drier side). Then use the appropriate recovery equipment to recover the refrigerant from the system. When the refrigerant has been recovered, install a piercing type valve on the low pressure side. IT IS IMPORTANT TO OPEN THE SYSTEM IN THIS ORDER TO KEEP THE OIL FROM BEING FORCED OUT.</p> <p>The use of piercing type valves will allow future servicing and eliminates the possibility of a defective pinch off.</p> <div data-bbox="602 726 1265 1010" data-label="Diagram"> <p>The diagram illustrates a refrigeration cycle. On the left is the Compressor, with a circled '2' indicating the low pressure side. The refrigerant flows clockwise through the Condenser, then through a Hot Line, then through a Drier, and finally through the Evaporator. A circled '1' is located on the high pressure line between the condenser and the drier, indicating the high pressure side.</p> </div>
3. Replacement of drier.	1) Be sure to replace drier with R134a only when repairing pipes and injecting refrigerant.
4. Nitrogen blowing welding.	<p>1) Use pressurized nitrogen to prevent oxidation inside the piping. (Nitrogen pressure : 0.1~0.2 kg/cm².)</p>
5. Others.	<p>1) Only nitrogen or R134a should be used when cleaning the inside of piping of the sealed system.</p> <p>2) Check leakage with an electronic leakage tester.</p> <p>3) Be sure to use a pipe cutter when cutting pipes.</p> <p>4) Be careful not the water let intrude into the inside of the cycle.</p>

TROUBLE DIAGNOSIS

3-4. Practical Work For Heavy Repair

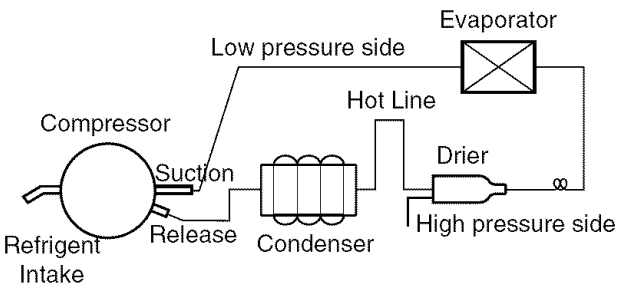
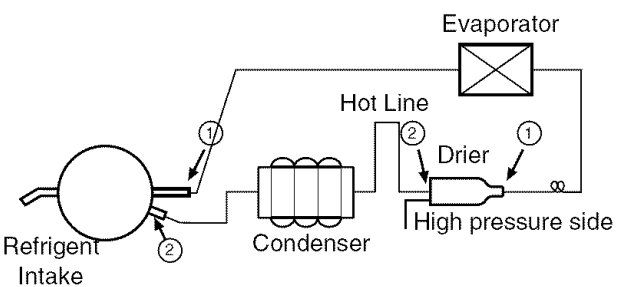
Items	Precautions
<p>1. Removal of residual refrigerant.</p>	<div style="display: flex; justify-content: space-between; align-items: flex-start;"> <div style="text-align: center;">  </div> <div style="width: 25%;"> <p>KEY POINT Observe the sequence for removal of refrigerant. (If not, compressor oil may leak.)</p> </div> </div> <p>1) Continue to recover the refrigerant for more than 5 minutes after turning the refrigerator off.</p> <p>2) Install a piercing type valve on the high pressure line (drier side). Then use the appropriate recovery equipment to recover the refrigerant from the system. When the refrigerant has been recovered, install a piercing type valve on the low pressure side. IT IS IMPORTANT TO OPEN THE SYSTEM IN THIS ORDER TO KEEP THE OIL FROM BEING FORCED OUT.</p> <p>The use of piercing type valves will allow future servicing and eliminates the possibility of a defective pinch off.</p>
<p>2. Nitrogen blowing welding.</p>	<div style="display: flex; justify-content: space-between; align-items: flex-start;"> <div style="text-align: center;">  </div> <div style="width: 25%;"> <p>KEY POINT Welding without nitrogen blowing produces oxidized scales inside a pipe, which affect performance and reliability of a product.</p> </div> </div> <p>When replacing a drier: Weld ① and ② parts by blowing nitrogen (0.1~0.2kg/cm²) to high pressure side after assembling a drier.</p> <p>When replacing a compressor: Weld ① and ② parts by blowing nitrogen to the low pressure side.</p> <p>Note) For other parts, nitrogen blowing is not necessary because it does not produce oxidized scales inside pipe because of its short welding time.</p>
<p>3. Replacement of drier.</p>	<div style="text-align: right;"> <p>KEY POINT Be sure to check the inserted length of capillary tube when it is inserted. (If inserted too far, the capillary tube will be blocked by the filter.)</p> </div> <p>Inserting a capillary tube Measure distance with a ruler and put a mark (12^{+3/-0}) on the capillary tube. Insert tube to the mark and weld it.</p>

TROUBLE DIAGNOSIS

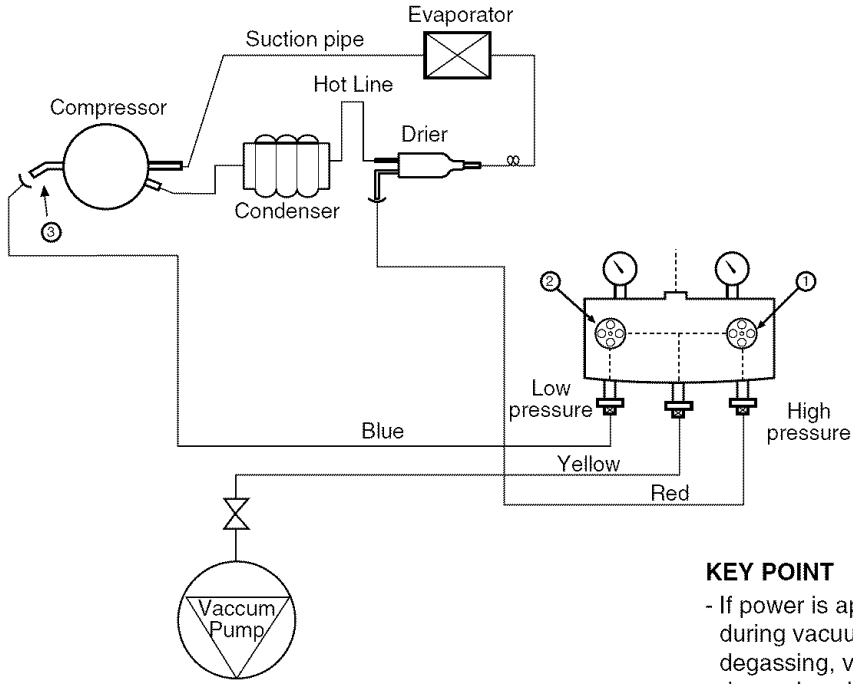
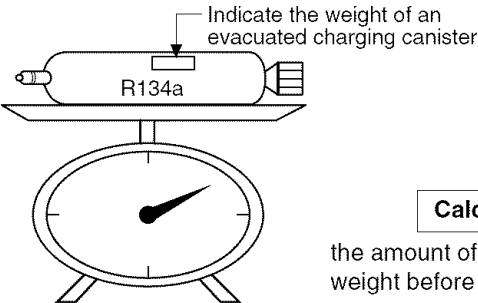
Items	Precautions
<p>4. Vacuum degassing.</p>	<div style="display: flex; justify-content: space-between;"> <div style="width: 60%;">  <p>Pipe Connection Connect the red hose to the high pressure side and the blue hose to the low pressure side.</p> <p>Vacuum Sequence Open valves ① and ② and evacuate for 40 minutes. Close valve ①.</p> </div> <div style="width: 35%;"> <p>KEY POINT</p> <ul style="list-style-type: none"> - If power is applied during vacuum degassing, vacuum degassing shall be more effective. - Run the compressor while charging the system. It is easier and works better. </div> </div>
<p>5. Refrigerant charging.</p>	<p>Charging sequence</p> <ol style="list-style-type: none"> 1) Check the amount of refrigerant supplied to each model after completing vacuum degassing. 2) Evacuate charging canister with a vacuum pump. 3) Measure the amount of refrigerant charged. <ul style="list-style-type: none"> - Measure the weight of an evacuated charging canister with an electronic scale. - Charge refrigerant into a charging canister and measure the weight. Calculate the weight of refrigerant charged into the charging canister by subtracting the weight of an evacuated charging canister. <div style="display: flex; justify-content: space-between; align-items: flex-start;"> <div style="width: 40%;">  </div> <div style="width: 55%;"> <p>KEY POINT</p> <ul style="list-style-type: none"> - Be sure to charge the refrigerant at around 25°C [77°F]. - Be sure to keep -5g in the winter and +5g in summer. <div style="border: 1px solid black; padding: 5px; text-align: center; margin-top: 10px;"> <p>Calculation of amount of refrigerant charged</p> </div> <p>the amount of refrigerant charged= weight after charging - weight before charging (weight of an evacuated cylinder)</p> </div> </div>

TROUBLE DIAGNOSIS

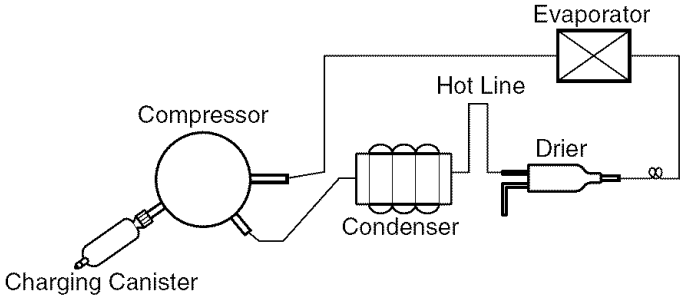
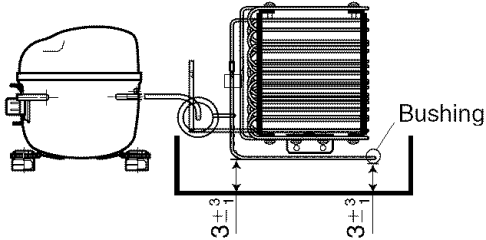
Items	Precautions
	 <p>4) Refrigerant Charging Charge refrigerant while operating a compressor as shown above.</p> <p>5) Pinch the charging pipe with a pinch-off plier after completion of charging.</p> <p>6) Braze the end of a pinched charging pipe with copper brazer and test for gas leakage at the brazed parts.</p>
6. Gas-leakage test	* Test for leaks on the welded or suspicious area with an electronic leakage tester.
7. Pipe arrangement in each cycle	<p>When replacing components, be sure each pipe is replaced in its original position before closing the cover of the mechanical area.</p> 

3-5. Standard Regulations For Heavy Repair

- 1) Observe the safety precautions for gas handling.
- 2) Use JIG (or a wet towel) in order to prevent electric wires from burning during welding. (In order to prevent insulation break and accident.)
- 3) The inner case will melt and the insulation will burn.
- 4) The copper piping will oxidize.
- 5) Do not allow aluminum and copper pipes to touch. (In order to prevent corrosion.)
- 6) Observe that the inserted length of a capillary tube into a drier should be $12^{+0.3}$ mm.

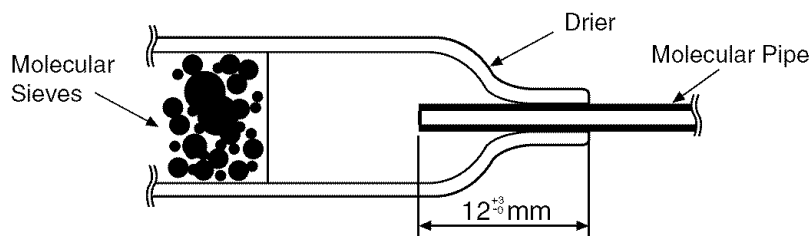

- 7) Make sure that the inner diameter is not distorted while cutting a capillary tube.
- 8) Be sure that the suction pipe and the filling tube should not be substituted each other during welding. (High efficiency pump.)

TROUBLE DIAGNOSIS

3-6. Brazing Reference Drawings

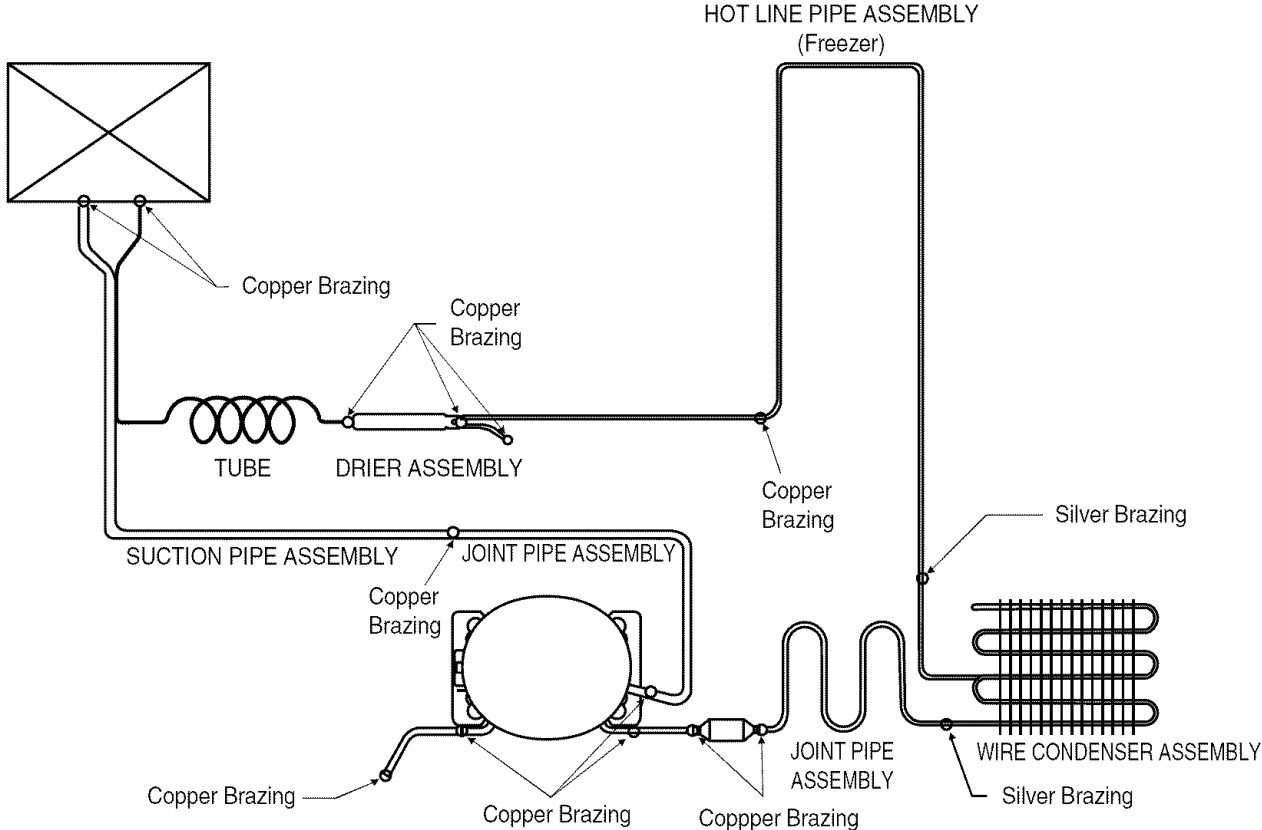

TROUBLE DIAGNOSIS

4. HOW TO DEAL WITH CLAIMS

4-1. Sound

Problems	Checks and Measures
Hiss sounds	<ul style="list-style-type: none"> ■ Explain general principles of sounds. <ul style="list-style-type: none"> • All refrigerators make noises when they run. The compressor and fan produce sounds. There is a fan in the freezer compartment which blows cool air to freezer and refrigerator compartments. Hiss sounds are heard when the air passes through the narrow holes into the freezer and refrigerator compartments. ■ Cooling Fan sound in the compressor compartment. <ul style="list-style-type: none"> • There is a fan on the back of the refrigerator which cools the compressor compartment. If there is a small space between the refrigerator and the wall, the air circulation sounds may be noticeable. ■ Compressor Noise <ul style="list-style-type: none"> • This operating sound happens when the compressor compresses the refrigerant. The compressor rotates at 3600 RPM. The sound of compressor Bigger refrigerators make more noise than small ones
Click sounds	<ul style="list-style-type: none"> ■ Explain the principles of temperature change. <ul style="list-style-type: none"> • The sounds happens when pipes and internal evaporator in the refrigerator compartment expand and contract as the temperature changes during the refrigerator operation. This sound also happens during defrosting, twice a day, when the ice on the evaporator melts.
Clunk sound	<ul style="list-style-type: none"> ■ Explain that it comes from the compressor when the refrigerator starts. <ul style="list-style-type: none"> • When the refrigerator operates, the piston and motor in the compressor rotate at 3600 RPM. This sound is caused by the vibration of motor and piston when they start and finish their operation. This phenomenon can be compared with that of cars. When an automobile engine starts, it is loud at first but quiets down quickly. When the engine stops, so does the vibration.
Vibration sound	<ul style="list-style-type: none"> ■ Check the sound whether it comes from the pipes vibration and friction. <ul style="list-style-type: none"> • Insert bushing or leave a space between pipes to avoid the noise. • Fix the fan blade if it is hitting on the shroud • Fix the drip tray if it is loosened. ■ Sound depends on the installation location. <ul style="list-style-type: none"> • Sound becomes louder if the refrigerator is installed on a wooden floor or near a wooden wall. Move it to another location. • If the refrigerator is not leveled properly, a small vibration can make a loud sound. Please adjust the level of the refrigerator.

TROUBLE DIAGNOSIS

Problems	Checks and Measures
<p>Sounds of water flowing</p>	<p>■ Explain the flow of refrigerant.</p> <ul style="list-style-type: none"> • When the refrigerator stops, the water flowing sound happens. This sound happens when the liquid or vapor refrigerant flows from the evaporator to compressor.
<p>Click sounds</p>	<p>■ Explain the characteristics of moving parts.</p> <ul style="list-style-type: none"> • This noise comes from the MICOM controller's switch on the top of the refrigerator when it is turned on and off.
<p>Noise of Icemaker operation (applicable to model with Icemaker). - Noise produced by ice dropping and hitting ice bin. - Noise from motor sounds Hiss.</p>	<p>■ Explain the procedure and principles of Icemaker operation.</p> <ul style="list-style-type: none"> • Automatic Icemaker repeats the cycle of water supplying → icemaking → ice ejection. When water is supplied, the water supply valve in the machine room makes sounds like Hiss and water flowing also makes sound. When water freezes, clicking sounds are heard. When ice is being ejected, sounds like Hiss produced by a motor to rotate an ice tray and ice dropping and hitting ice bin sounds are also heard.
<p>Noise when supplying water.</p>	<p>■ Explain the principles of water supplied to dispenser.</p> <ul style="list-style-type: none"> • When the water supply button in the dispenser is pressed, the water supply valve in the compressor compartment opens and let the water flow to the water tank in the lower part of the refrigerator compartment. The water is dispensed by this pressure. When this happens, motor sound and water flowing sound are heard.
<p>Noise when supplying ice.</p>	<p>■ Explain the principles of ice supply and procedure of crushed icemaking in a dispenser.</p> <ul style="list-style-type: none"> • When ice cube button is pressed, ice stored in the ice bin is moved by an auger and dispensed. If crushed ice button is pressed, the ice cube is crushed. When this happens, ice crushing and hitting ice bin sounds are heard.

TROUBLE DIAGNOSIS

4-2. Measures for Symptoms on Temperature

Problems	Checks and Measures
Refrigeration is weak.	<p>■ Check temperature set in the temperature control knob.</p> <ul style="list-style-type: none"> • Refrigerator is generally delivered with the button set at normal use (MID). But customer can adjust the temperature set depending on their habit and taste. If you feel the refrigeration is weak, then set the temperature control button at strong position. If you adjust the button in the freezer compartment as well, the refrigeration is stronger than adjusting refrigerator only.
The food in the chilled drawer is not frozen but defrosted.	<p>■ The chilled drawer does not freeze food.</p> <ul style="list-style-type: none"> • Use chilled drawer for storing fresh meat or fish for short periods. For storing for a long periods or freezing food, use a freezer compartment. It is normal that frozen foods thaw above the freezing temperature (in the chilled drawer).
Refrigerator water is not cool.	<p>■ Check the water storage location.</p> <ul style="list-style-type: none"> • If water is kept in the door rack, move it to a refrigerator shelf. It will then become cooler.
Ice cream softens.	<p>■ Explain the characteristics of ice cream.</p> <ul style="list-style-type: none"> • The freezing point of ice cream is below -15°C (5°F). Therefore ice cream may melt if it is stored in the door rack. • Store ice cream in a cold place or set the temperature control button of a freezer at strong position.
Refrigeration is too strong.	<p>■ Check the position of temperature control button.</p> <ul style="list-style-type: none"> • Check if refrigeration is strong in whole area of the refrigerator or partly near the outlet of the cooling air. If it is strong in whole area, set the control button at weak. If it is strong only near the outlet of cool air, keep food (especially damp foods and easily frozen foods) away from the outlet.
Vegetables are frozen.	<p>■ Check the vegetables storage.</p> <ul style="list-style-type: none"> • If vegetables are stored in the refrigerator shelf or chilled drawer instead of vegetable drawer, they will be frozen. Set the control button at weak if they are also frozen in the vegetable drawer.
The food stored at inside of the shelf freezes even the control button is set at MID .	<p>■ Check if food is stored near the outlet of the cooling air.</p> <ul style="list-style-type: none"> • The temperature at cooling air outlet is always below the freezing point. Do not store food near the outlet of the cooling air as it block the air circulation. Do not block the outlet. If the outlet of the cooling air is blocked, the refrigerator compartment will not be cooled.

TROUBLE DIAGNOSIS

4-3. Odor and Frost

Problems	Checks and Measures
Odor in the refrigerator compartment.	<p>■ Explain the basic principles of food odor.</p> <ul style="list-style-type: none"> • Each food has its own particular odor. Therefore it is impossible to prevent or avoid food odor completely when food is stored in the completely sealed refrigerator compartment. The deodorizer can absorb some portions of the odor but not completely. The intensity of odor depends on refrigerator conditions and environments. <p>■ Check the temperature control button and set at strong.</p> <ul style="list-style-type: none"> • Clean inside of the refrigerator with detergent and remove moisture. Dry inside the refrigerator by opening the door for about 3 or 4 hours and then set the temperature control button at strong.
Frost in the freezer compartment	<p>■ Explain the basic principles of frost formation.</p> <ul style="list-style-type: none"> • The main causes for frosting: <ul style="list-style-type: none"> - Door was left open. - Air penetration through the gasket - Too frequent door opening. (parties. etc.) - Hot foods are stored before they are cooled down. The temperature of freezer is -19°C (-2.2°F). if temperature is set at MID. If hot air comes into the refrigerator, fine frost forms as cold air mixes with hot air. If this happens quite often, much frost forms inside of the refrigerator. If the door is left open in Summer, ice may form inside of the refrigerator.
Frost in ice tray.	<p>■ Explain basic principles of frost formation.</p> <ul style="list-style-type: none"> • When ice tray with full of water is put into a freezer compartment, the water evaporates. If cool air fan operates, the moisture attached to the jaw (protruded part) of ice mold will freeze and form frost. If warm water was put into the ice mold, the situation will become worse.

4-4. Weather Forecast

My refrigerator does NOT display weather forecast information.

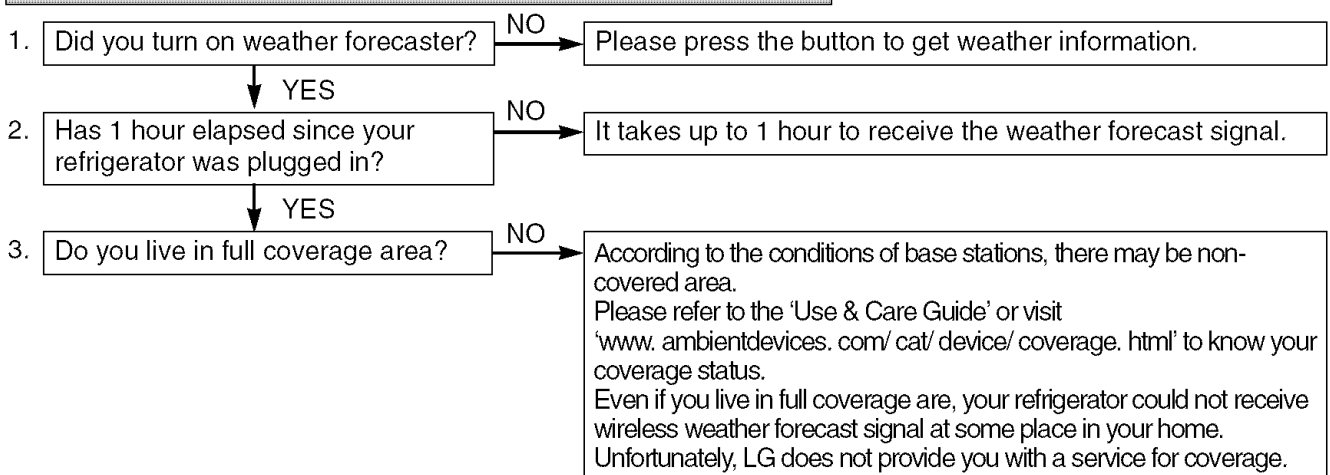

TROUBLE DIAGNOSIS

4-5. Others

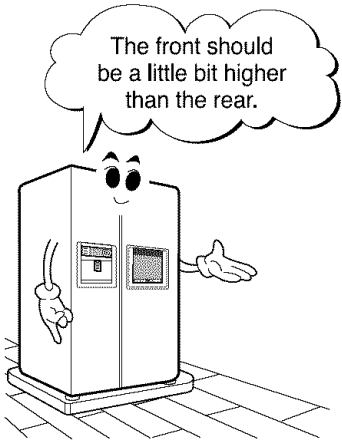
Problems	Checks and Measures
The refrigerator case is hot.	<ul style="list-style-type: none"> ■ Explain the principles of radiator. <ul style="list-style-type: none"> • The radiator pipes are installed in the refrigerator case and partition plate between the refrigerator and the freezer compartment in order to prevent condensation formation. Particularly in summer or after installation of refrigerator, it may feel hot but it is normal. If there is not enough space to dissipate heat, it can be hotter due to lack of heat radiation. Please install a refrigerator in a well-ventilated place and leave the clearance between refrigerator and wall:
Small holes in a door liner	<ul style="list-style-type: none"> ■ Explain that the hole is for releasing air during the manufacturing process. <ul style="list-style-type: none"> • These small holes in the plastic of the refrigerator allow the plastic parts to be molded and the foam insulation to be pumped in. The holes allow the air to be expelled so there are no bubbles.
Electric bills are too much.	<ul style="list-style-type: none"> ■ If the electric bill seems high, make sure the refrigerator is the cause rather than a general increase in the cost of electricity. This refrigerator may be larger than your previous refrigerator, and therefore require more power.
Condensation on the inside wall of the refrigerator compartment and the cover of properly vegetable drawer.	<ul style="list-style-type: none"> ■ Explain how to store foods <ul style="list-style-type: none"> • Condensation forms when refrigerator is installed at damp area, door is frequently opened, and wet foods are not stored in the air tight container or wrapped. Be sure to store wet foods in airtight containers or securely covered in plastic wrap.
When is the power connected?	<ul style="list-style-type: none"> ■ When should the power be connected ? <ul style="list-style-type: none"> • You can connect the power immediately after installation. However, if the refrigerator was laid flat before or during installation, you must stand it upright for 6 hours before plugging it in. This allows the refrigerant oils to return to the sump in the compressor. If you operate the refrigerator before the oil has had a chance to settle, you could damage the compressor.
Door does not open properly. <div style="text-align: center; margin-top: 20px;">  </div>	<ul style="list-style-type: none"> ■ Refrigerator compartment door does not open properly. <ul style="list-style-type: none"> • When the door is opened, warm air goes inside the refrigerator. When it cools, it creates a slight vacuum, which makes the door a little harder to open. This will diminish over time. ■ When the refrigerator compartment door is opened and closed, the freezer compartment door moves up and down. <ul style="list-style-type: none"> • When the refrigerator compartment door is opened and closed, fresh air comes into the freezer compartment and moves up and down the freezer compartment door. ■ Door opens too easily. <ul style="list-style-type: none"> • There is a magnet in the gasket so it closes securely without a gap. It can be held open easily if something is in the way and obstructs the door's closing. ■ Door does not close properly. <ul style="list-style-type: none"> • If the refrigerator is not properly leveled, the doors will not close easily. Adjust the level using the leveling screws under the front of the refrigerator.

TV-RADIO

1. SAFETY PRECAUTIONS

1-1. Warning

1. Be sure to make a safety check, if circuit is found, components that appear to have overheated or are otherwise damaged should be replaced with new components.
2. After servicing, be sure that the protected equipment is assembled.
3. When you don't watch TV, use the POWER button turn it off.

1-2. Notes

1. When inserting the instrument or circuit board, fix the leads to the jack, before soldering.
2. Insert higher voltage resistors with a 10mm gap above the PWB.
3. Don't touch hot chassis leads.

2. FEATURE

2-1. Auto Program tuning

All stations that can be received are stored.

2-2. Auto Sleep

TV will automatically switch itself to standby mode approximately ten minutes after TV station stops broadcasting.

2-3. Auto Search (FM RADIO)

Press the TV/AV/RADIO button and then hold CH▲ or CH▼ button for more than 1 second to search RADIO Channel.

TV-RADIO

3. CONTROLS

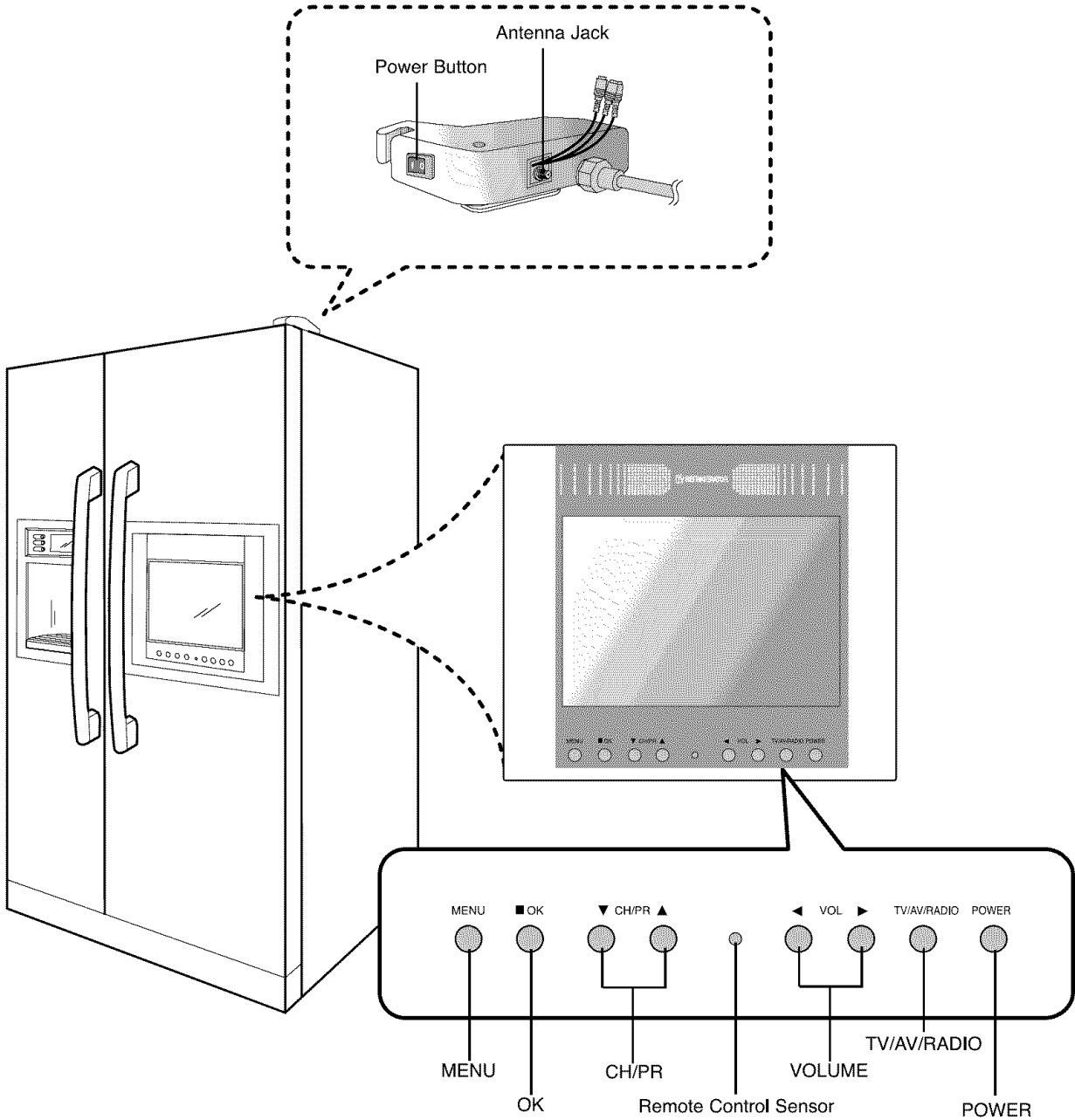

TV-RADIO

4. REMOTE CONTROL KEY FUNCTIONS

- When using the remote control, aim it at the remote control sensor on the TV.

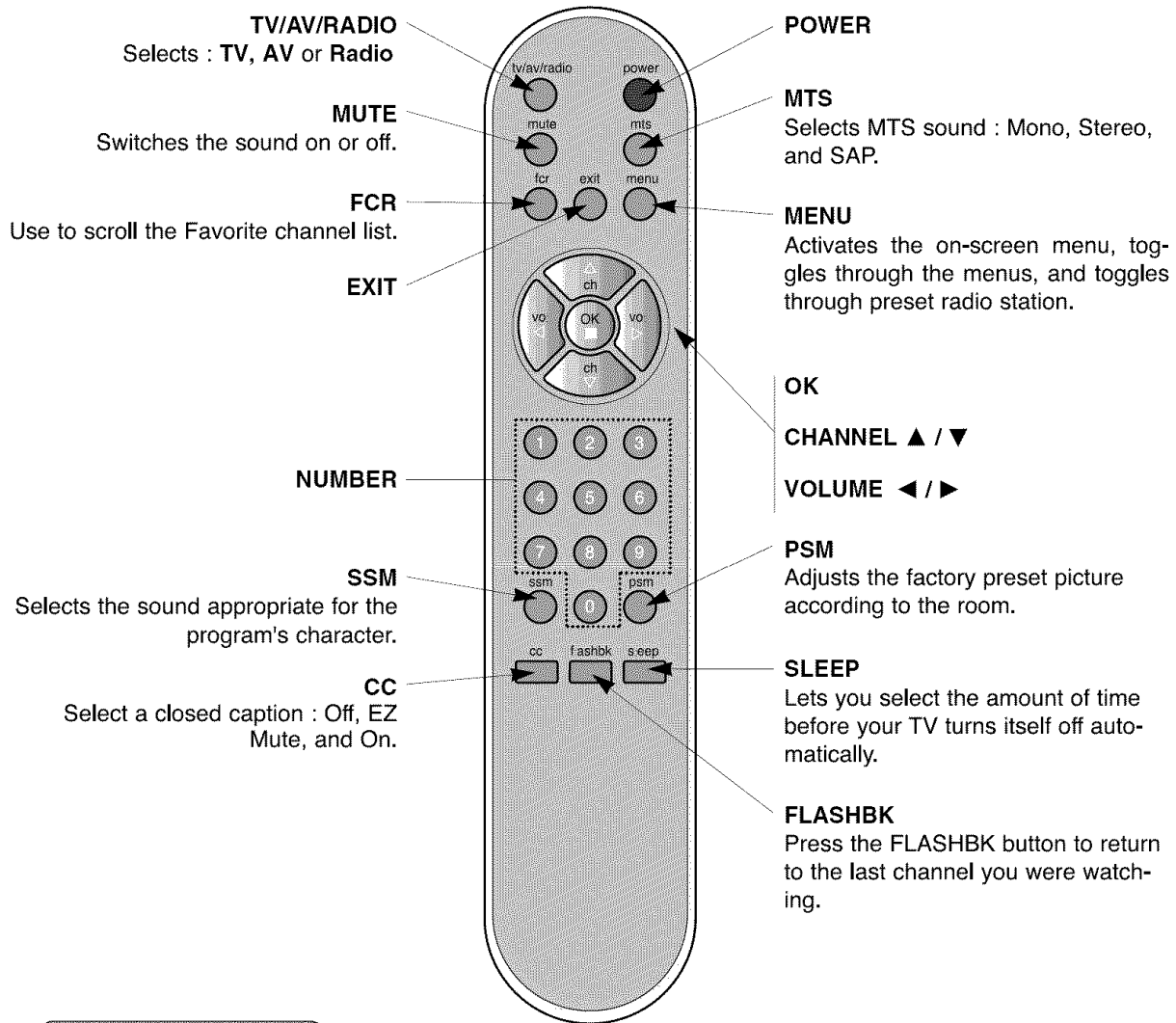

Installing Batteries

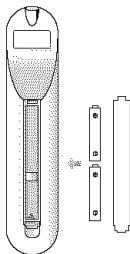

- Open the battery compartment cover on the back side and insert the batteries with correct polarity.
- Install two 1.5V batteries of AAA type. Don't mix used batteries with new batteries.

TV-RADIO

S5. TROUBLESHOOTING

5-1. General

No.	Poor	Symptoms	Adjustment
1	No Picture	1) No P401, P501 connector 2) Poor TV Main PCB	1) Check P1 connector and switched on 2) Change the TV Main PCB
2	Poor Picture	1) Poor LCD Lamp 2) LCD Connector	1) Change the LCD 2) Check connector and switched on

5-2. TV

No.	Poor	Symptoms	Adjustment
1	No Sound	1) No P601, P602 connector 2) Poor speaker 3) Poor TV Main PCB	1) Check connector and switched on 2) Change the speaker 3) Change the TV Main PCB
2	Poor Radiant heat Fan	1) Fan turning abrades wire and tape. 2) Poor Fan	1) Detach Fan and remove the interference. 2) Change the Fan
3	No TV broadcast	1) No TV connection (Hinge Cover, Back TV)	1) Check connection and switch on
4	Button does not work	1) No P105 connector 2) Poor switch	1) Check connector and switch on 2) Change the Button PCB
5	Remote Control does not work	1) No P105 connector 2) Poor Remote Control sensor 3) Poor Remote Control	1) Check connector and switched on 2) Change the Button PCB 3) Change the Remote Control

5-3. FM Radio

No.	Poor	Symptoms	Adjustment
1	No Sound	1) Poor FM Radio Tuner	1) Charge FM Radio Tuner.

TV-RADIO

6. BLOCK DIAGRAM

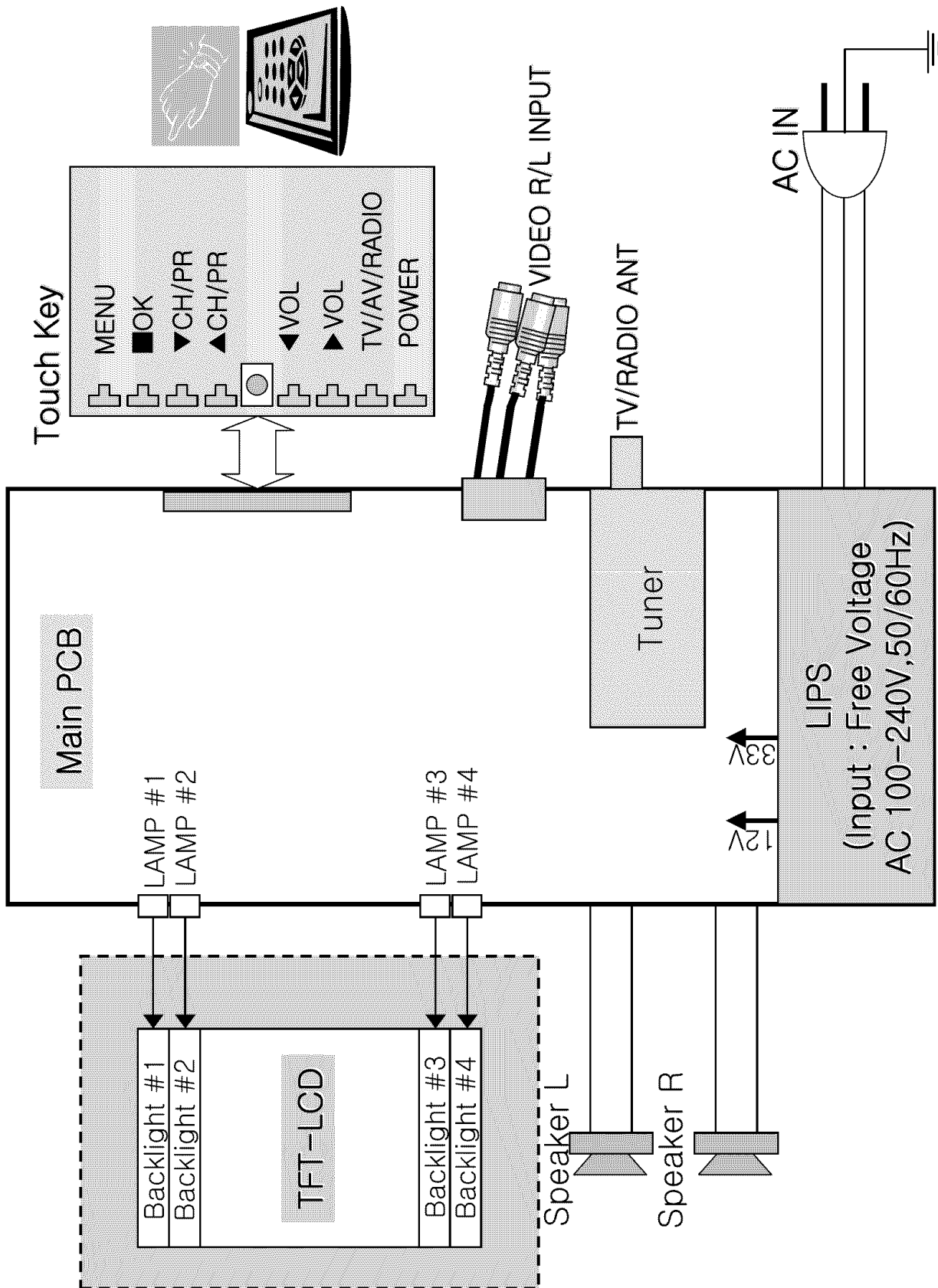

TV-RADIO

7. TV PART DISASSEMBLE

1

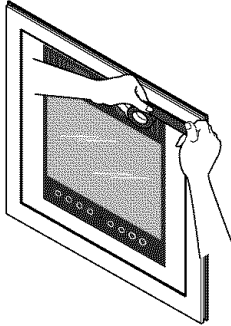

Place tape on the outer edge of the TV case to protect the soft plastic from damage (2 or 3 layers is recommended).

2

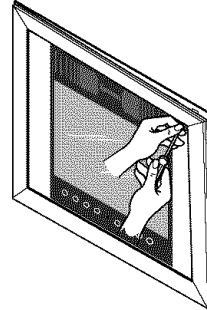

Using a flat bladed screwdriver, carefully pry the trim loose from the frame.

3

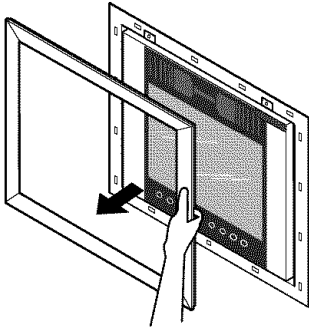

Carefully remove the trim.

4

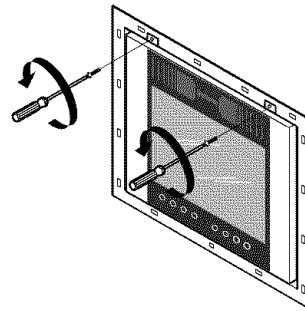

Remove two phillips head screws located at the top of the TV.

5

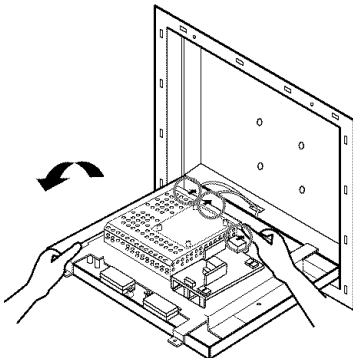

Tip the TV forward and disconnect all wires.

6

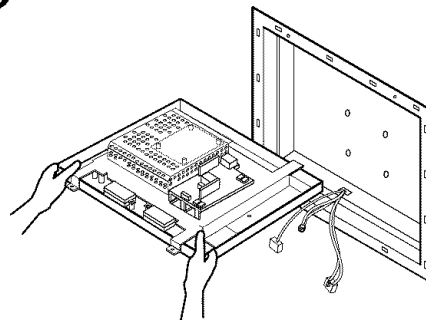

Carefully remove the TV.

HOW TO DISASSEMBLE AND ASSEMBLE

1. DOOR

1) Remove lower cover and then disconnect water supply tube in the lower part of freezer door.

- Pull the water supply tube ② forward while pressing on the coupling ① as shown in the drawing.

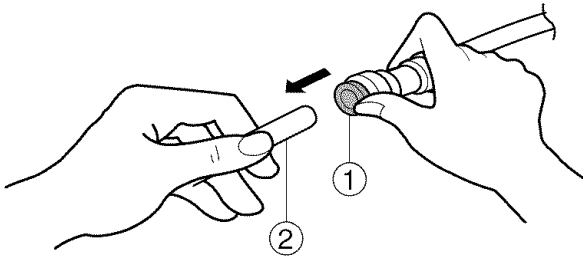

- ⚠ Disconnecting the tube under the door causes about 3 pints (1.5 liters) of water to flow out. Use a big container to catch it.

Note : Connect the same tube color.

2) Remove the a freezer door.

- (1) Loosen hinge cover screw of freezer door and remove the cover.
Disconnect all connecting lines except grounding cord.

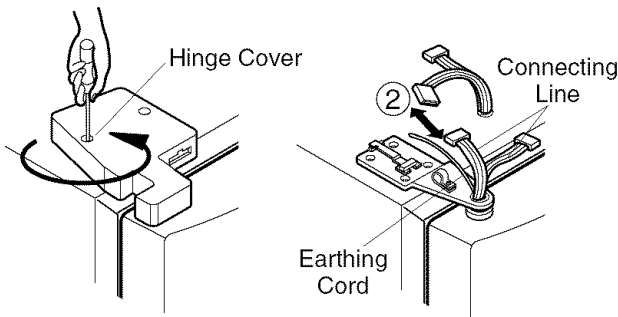

- (2) Turn hinge lever in arrow (A) direction until it is loosened and take it out in arrow (B) direction.

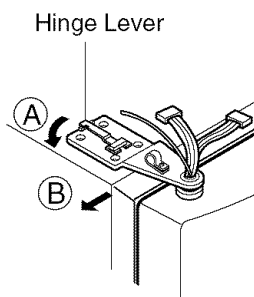

- **Note :** When disconnecting refrigerator door, turn hinge lever counterclockwise.

- If the hinge or bracket are bent during assembly, use two extra screws (Tap Tite M6, Left Hinge attaching screw) in the holes of the upper hinge.

- (3) Disconnect upper hinge ① from the hinge supporter ② by grasping the front part of upper hinge and lifting up (Hinge Assembly, U) in arrow direction (A) and pull forward in arrow (B) direction. Be careful because the door may fall, damaging the door, the floor, or injuring you.

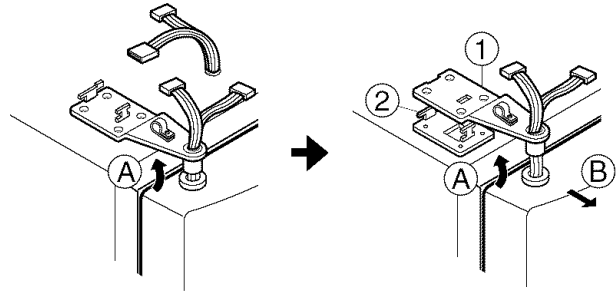

- (4) Lift up the freezer door ① in arrow direction and disconnect the door from the lower hinge ②. Don't pull the door forward.

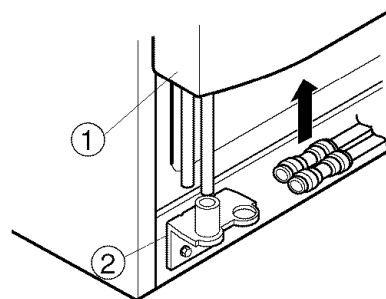

- **Note :** Lift up the freezer door until the water supply tube is fully taken out.

- (5) Assembly is the reverse order of disassembly

HOW TO DISASSEMBLE AND ASSEMBLE

2. HANDLE

1) Aluminum short handle Model

(1) Grasp the handle by both hands and hold it upward.

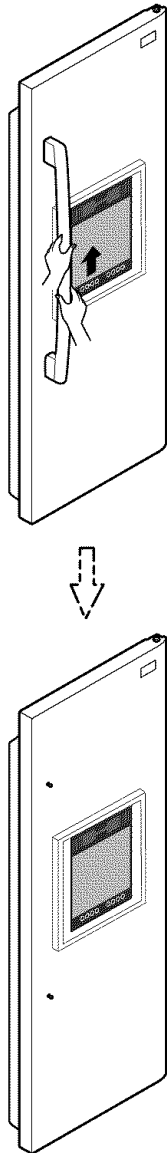

3. FAN SHROUD GRILLE

- 1) Remove the caps and remove the two screws holding the upper fan grille.
- 2) Remove the upper fan grille by pressing in the hooks with a screwdriver blade. Be careful to avoid breaking the plastic.
- 3) Disconnect electrical connector A and remove the upper fan grille.
- 4) Hold the upper part of the lower fan grille and pull it forward carefully.
- 5) Loosen two screws.
- 6) Disconnect electrical connector B on the back fan housing. Use a screwdriver blade to remove the 2 rails and the fan housing.
- 7) Pull the fan housing out from the top.
- 8) Check the adhesive foam on the upper and lower fan grilles. If it is damaged, torn, or loose, replace it.

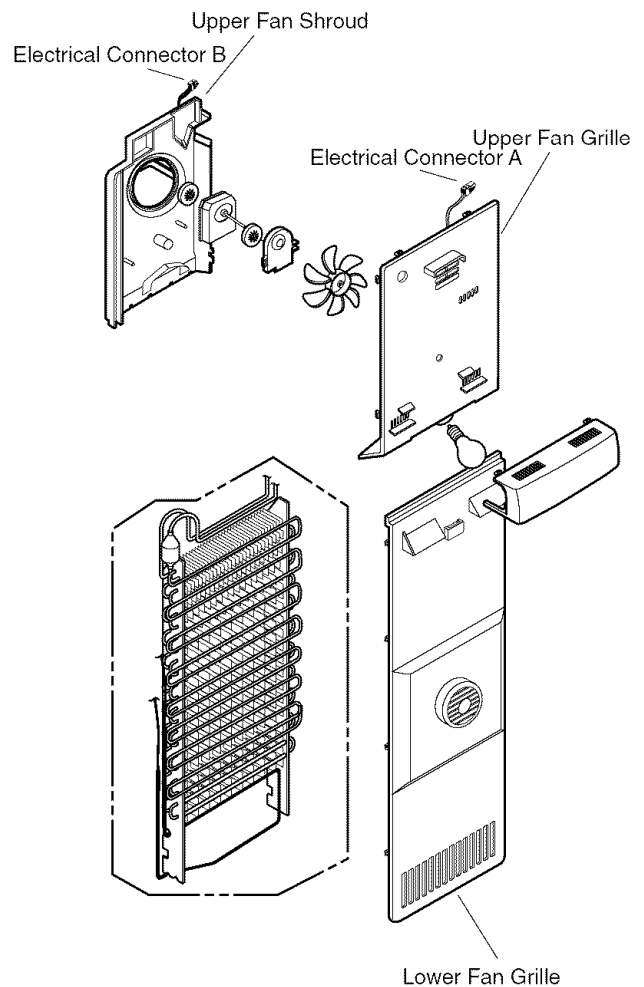

HOW TO DISASSEMBLE AND ASSEMBLE

4. WATER VALVE DISASSEMBLY METHOD

- 1) Turn off the power of the refrigerator (pull out the plug).
Open the FREEZER and REFRIGERATOR Door and disassemble the Lower Cover.

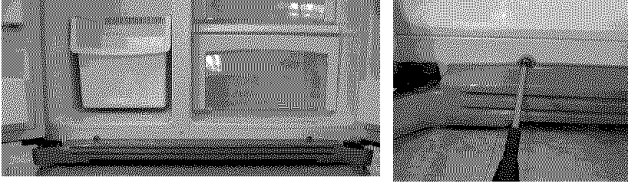

- 2) Lay a dry towel on the floor and get ready to spill water from the water tank.
Pull out the Clip. Then press the collet to separate the tube from the connector and pour out the water until emptied.
(Refer to the label attached on Front L on how to separate the tube.)

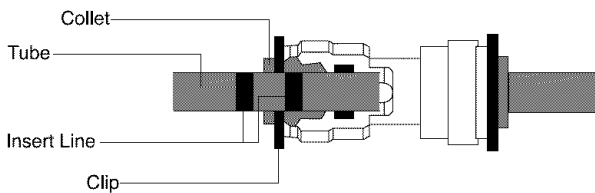

- 3) Turn off the water. Then separate the water line from the valve.

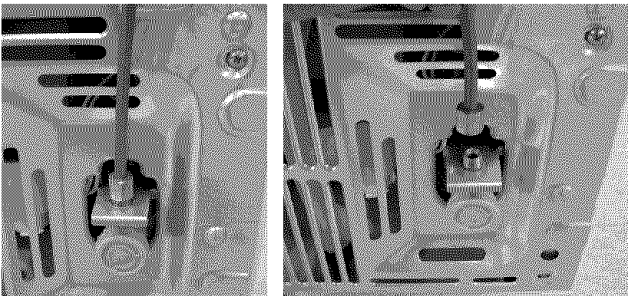

- 4) Separate the Mechanical Cover and Valve Screw.

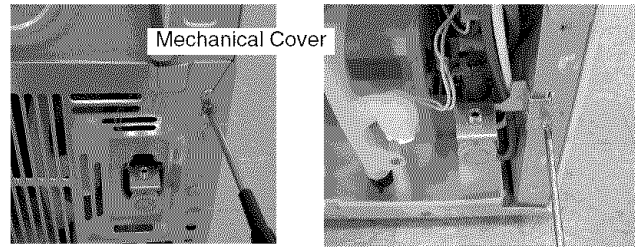

- 5) Separate the housing and pull out the valve.

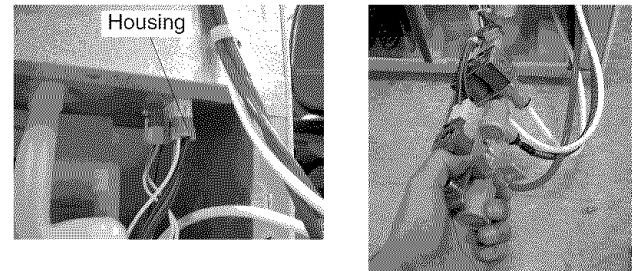

5. FAN AND FAN MOTOR DISASSEMBLY METHOD

- 1) Using a short screwdriver, loosen one SCREW in DRAIN PIPE ASSEMBLY and one connected to the MOTOR COVER.

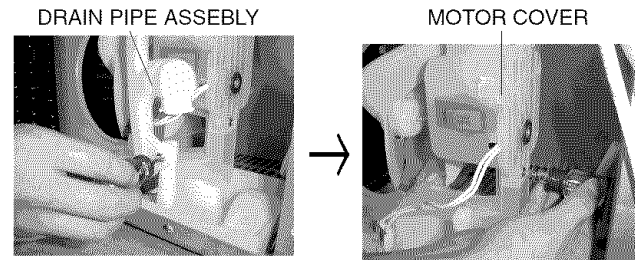

- 2) Pull and separate the FAN ASSEMBLY and MOTOR turning counterclockwise based on the MOTOR SHAFT.

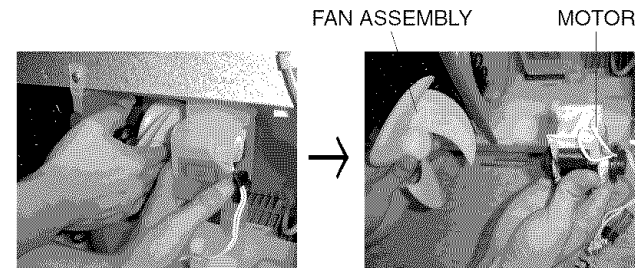

The assembly is in the reverse order of the disassembly and take special care for the following details.

1. Be careful not to bend the tube during assembly.
2. Press the WATER DISPENSER button until water pours out and check for leakage in the CONNECTOR TUBE (It differs by the water pressure but usually takes about 2 minutes until water pours out.)

HOW TO DISASSEMBLE AND ASSEMBLE

6. DISPENSER

1) Disconnect funnel and button assembly by pulling down and forward.

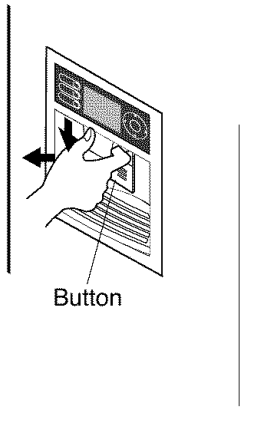

4) Loosen four screws with a phillips screwdriver and pull the funnel assembly to disconnect.

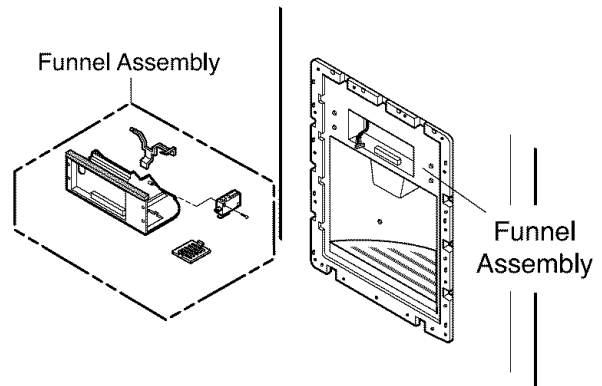

2) Remove display frame assembly by making a gap between a display frame assembly and door with a flat blade screwdriver and pulling it forward. The cover dispenser is attached with a hook.

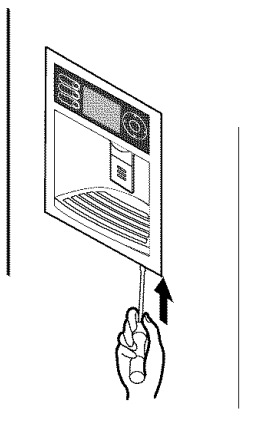

5) The duct cap assembly can be disconnected if the hold lever connecting screw is loosened with a phillips driver.

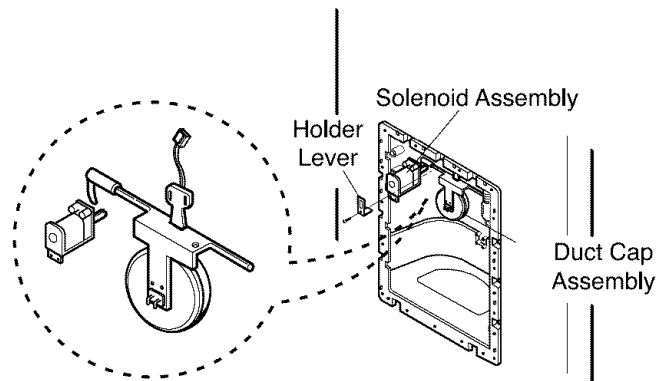

3) The display assembly can be connected by pressing the top of the dispenser cover and pushing it after separating the display frame from its housing.

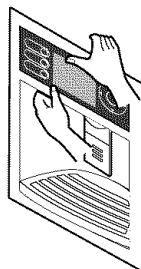

6) To install the duct cap assembly, insert one end of the spring into the right hole of the dispenser lever and insert the other end into the right hole in the top part of the dispenser. Then attach the holder at the solenoid switch.

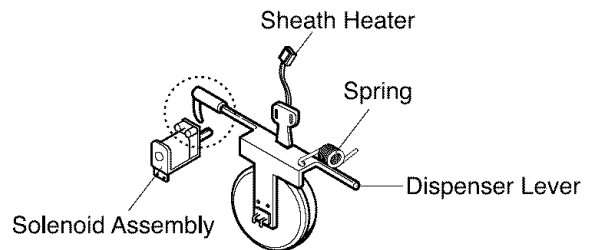

HOW TO DISASSEMBLE AND ASSEMBLE

7) Dispenser Related Parts

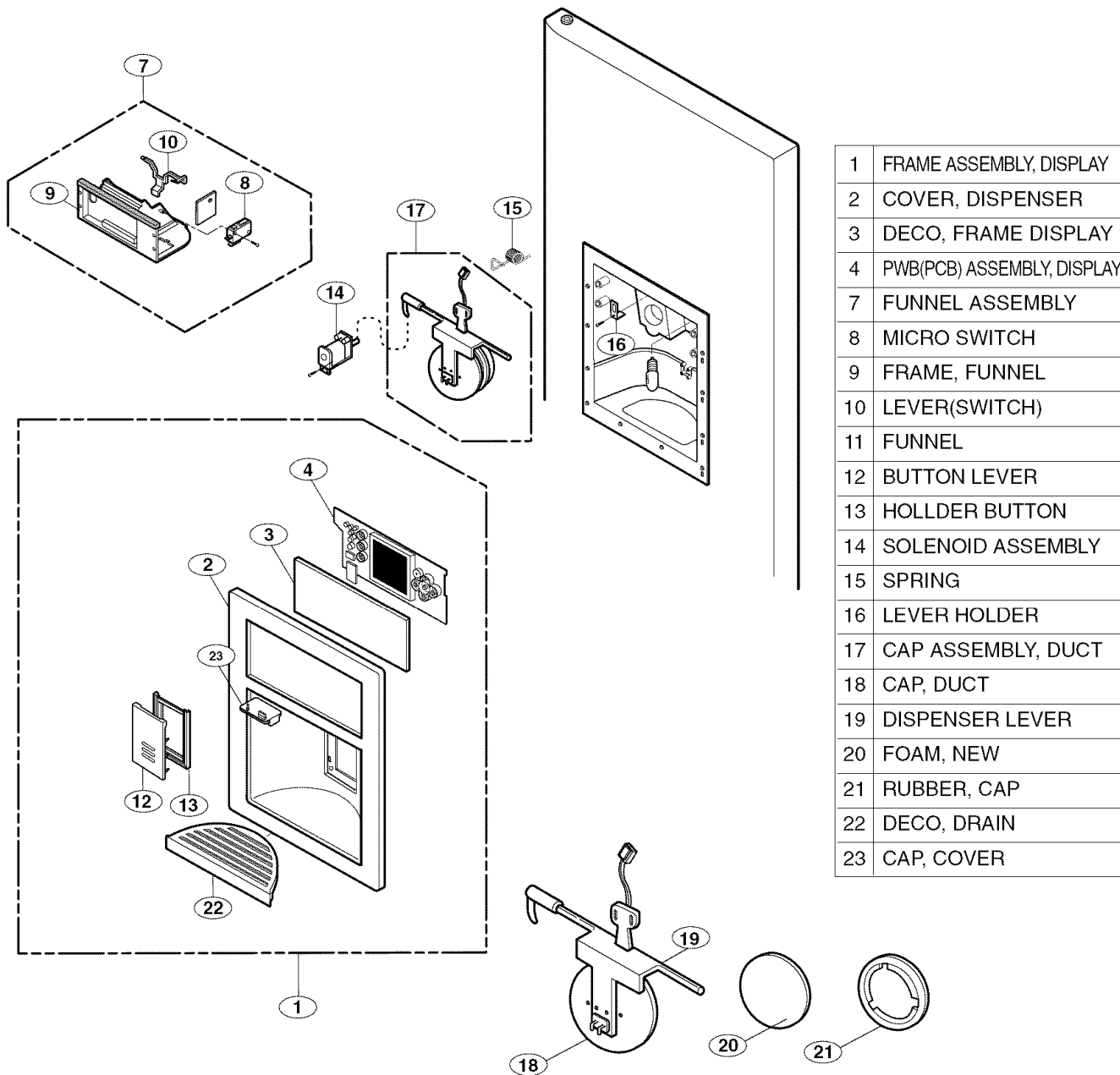

NOTE : Not every model includes every option

EXPLODED VIEW

FREEZER DOOR PART: GR-G277STSA(LSC27990TT)

* : Optional part

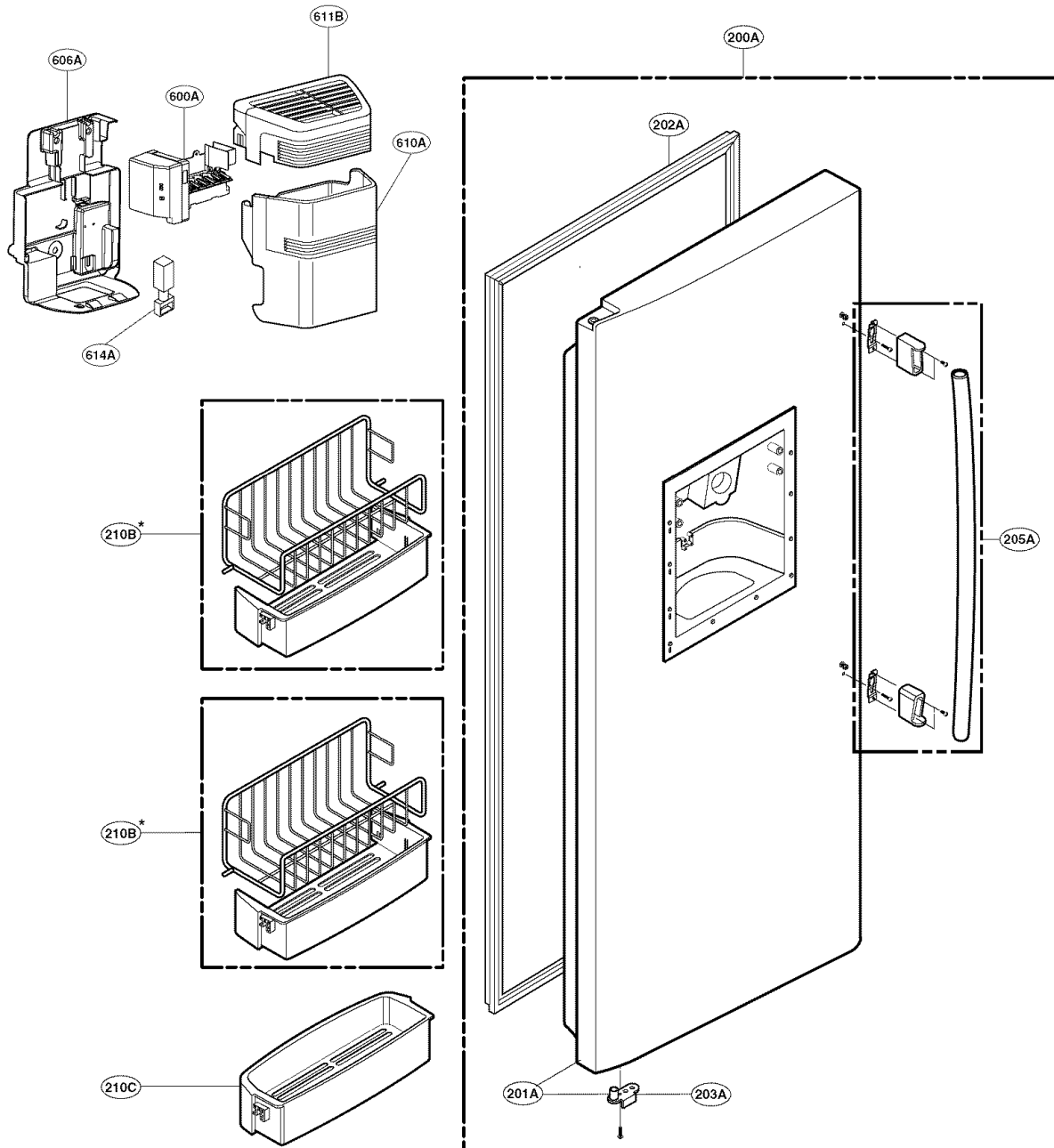

EXPLODED VIEW

REFRIGERATOR DOOR PART: GR-G277STSA(LSC27990TT)

* : Optional part

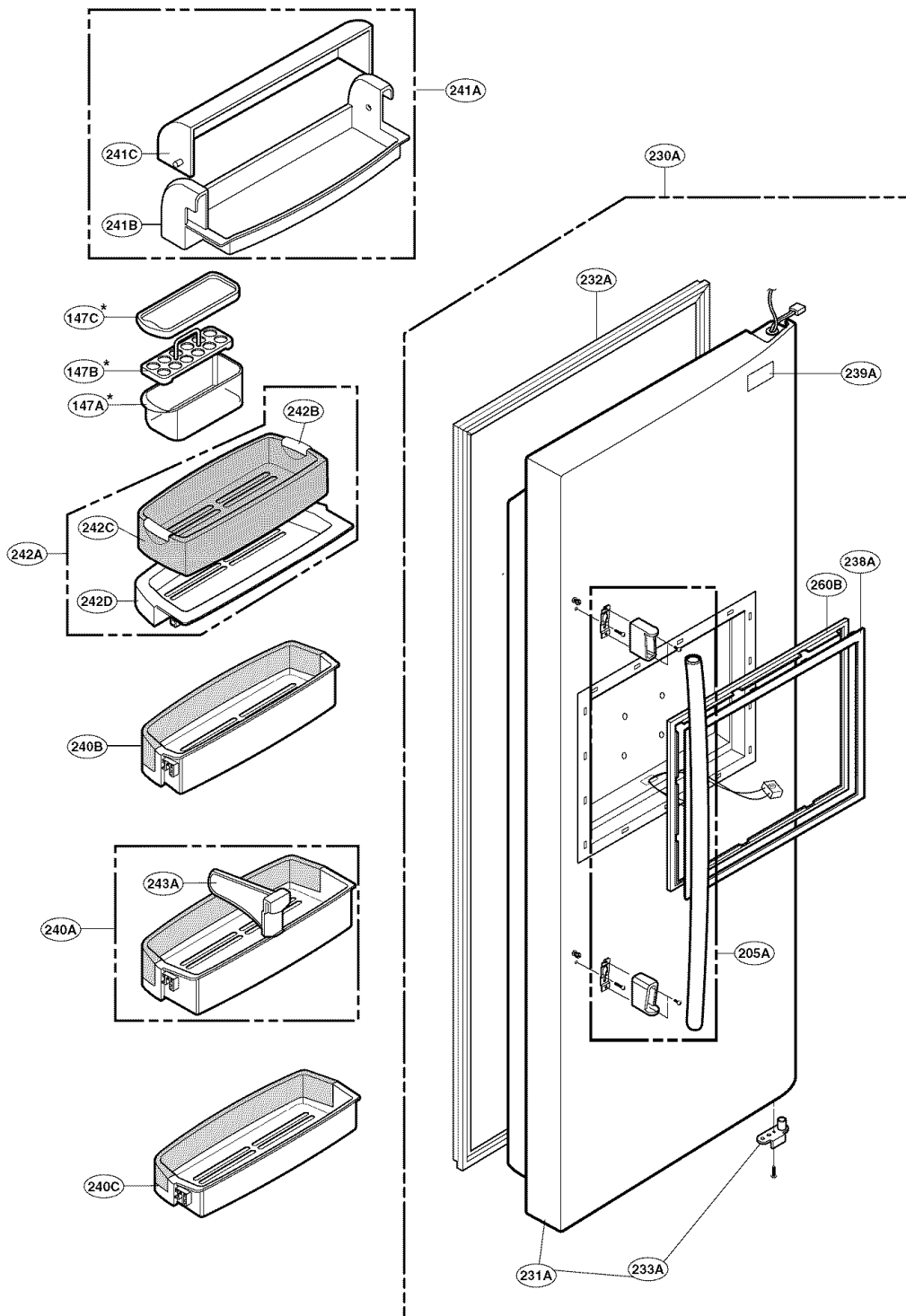

EXPLODED VIEW

REFRIGERATOR COMPARTMENT: GR-G277STSA(LSC27990TT)

* : Optional part

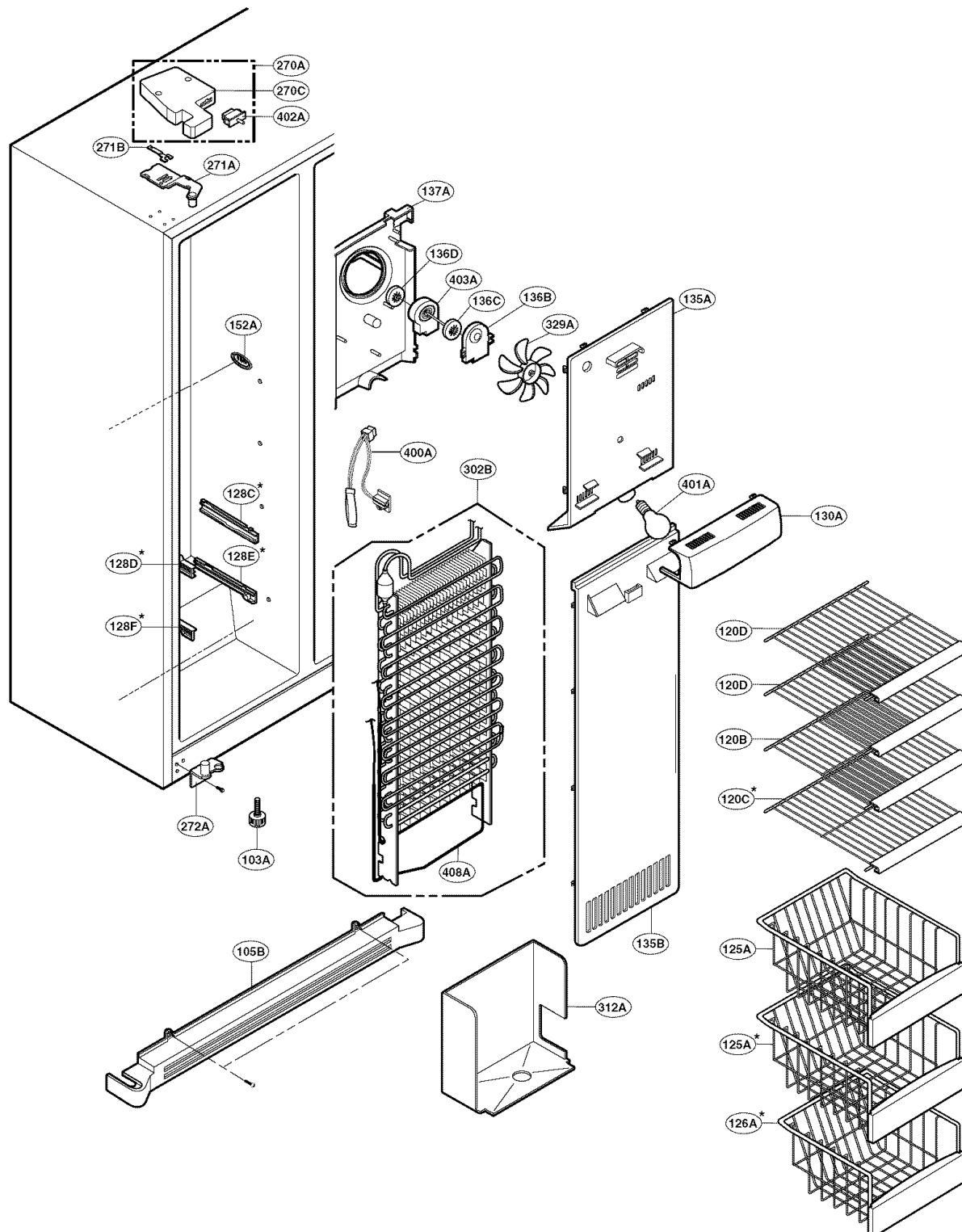

EXPLODED VIEW

REFRIGERATOR COMPARTMENT: GR-G277STSA(LSC27990TT)

* : Optional part

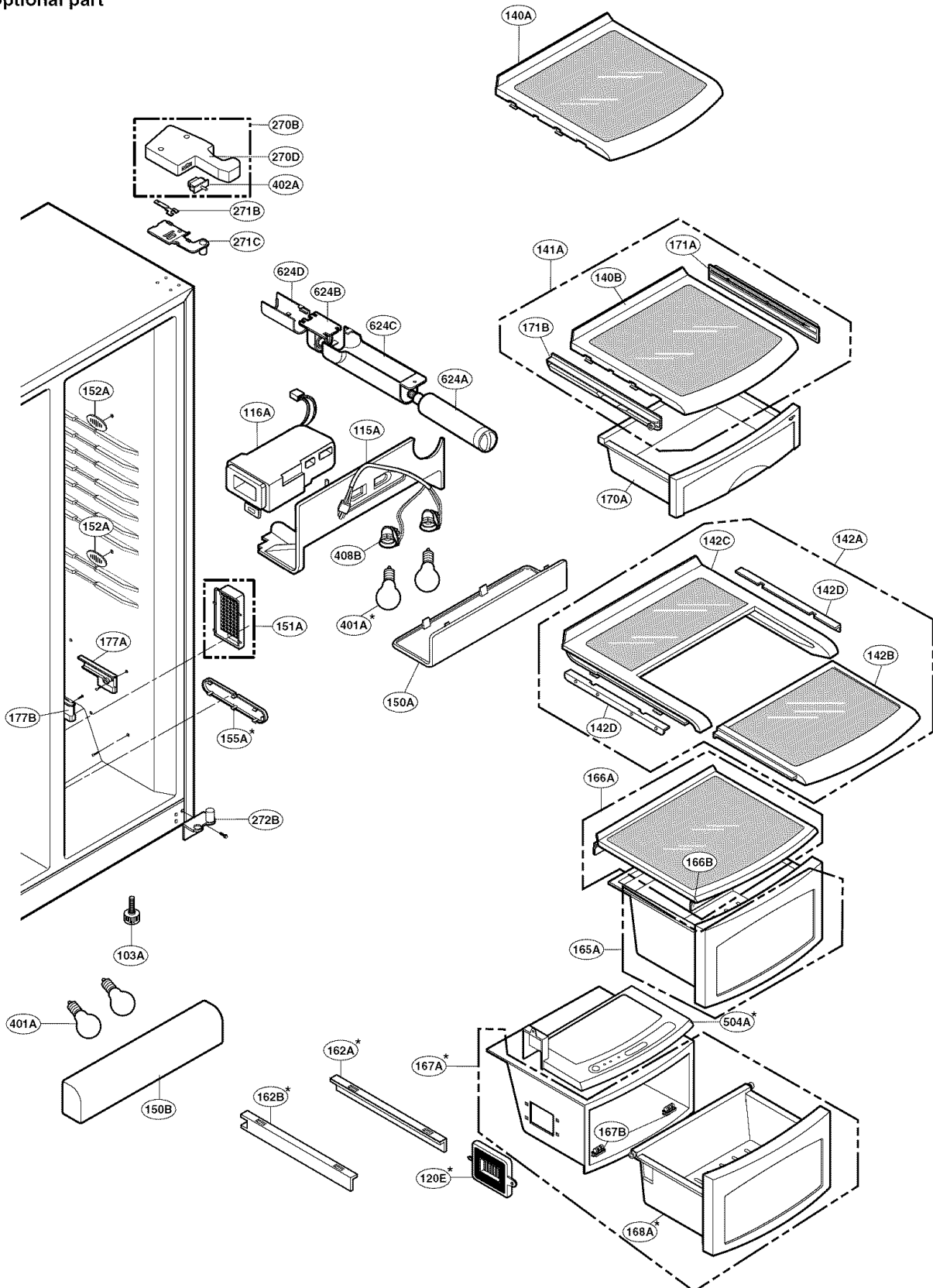

EXPLODED VIEW

MACHINE COMPARTMENT: GR-G277STSA(LSC27990TT)

* : Optional part

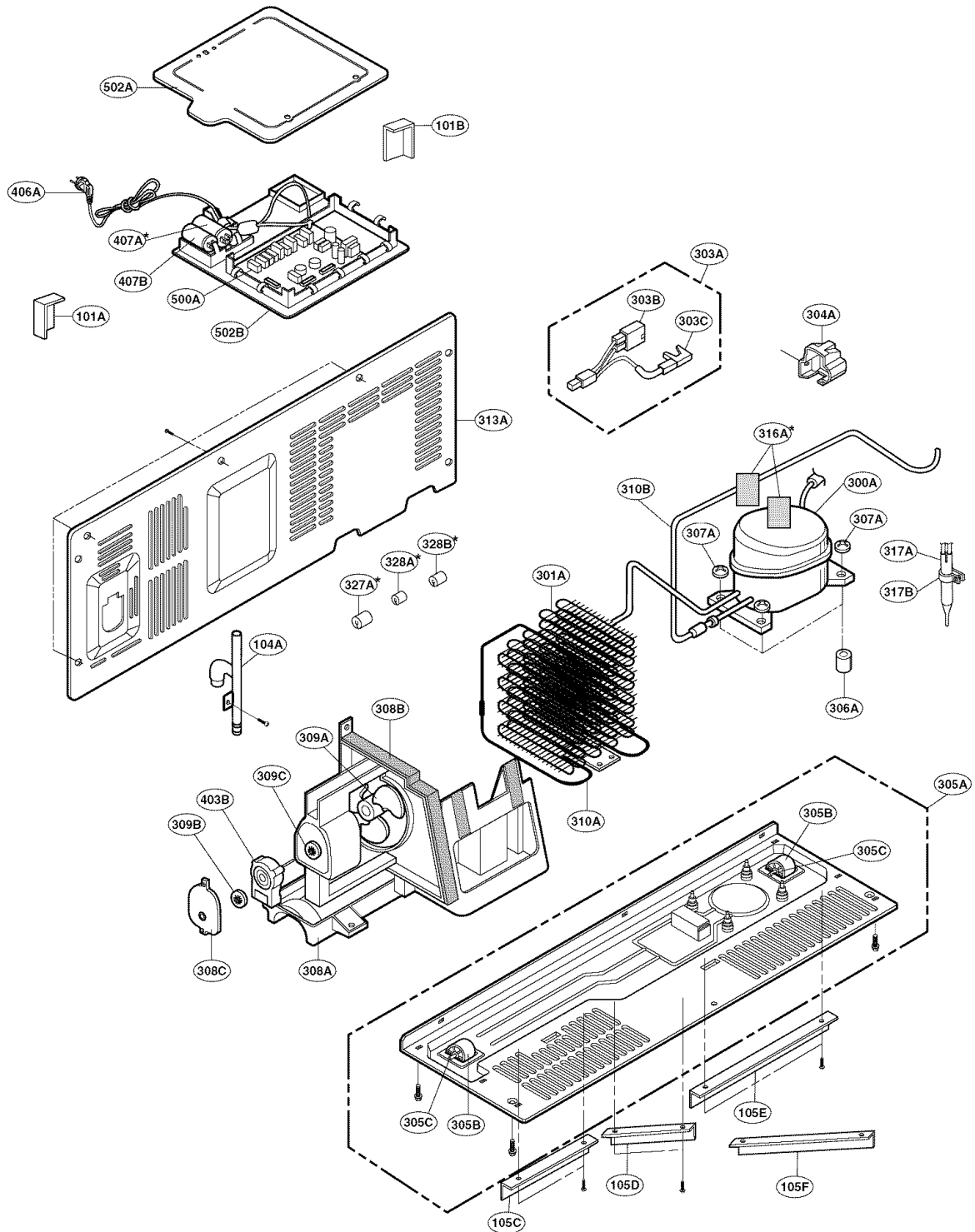

EXPLODED VIEW

DISPENSER PART: GR-G277STSA(LSC27990TT)

* : Optional part

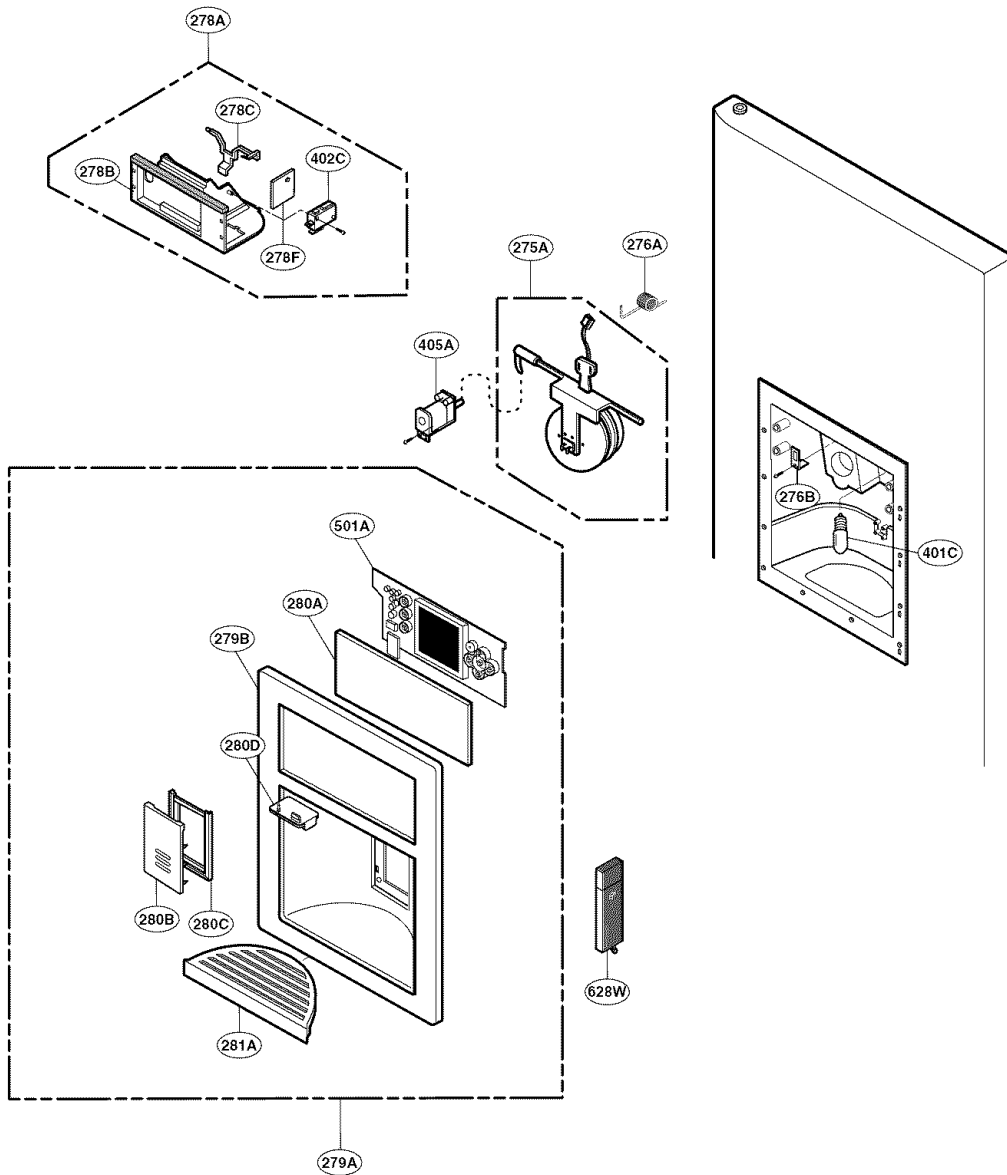

EXPLODED VIEW

TV PART: GR-G277STSA(LSC27990TT)

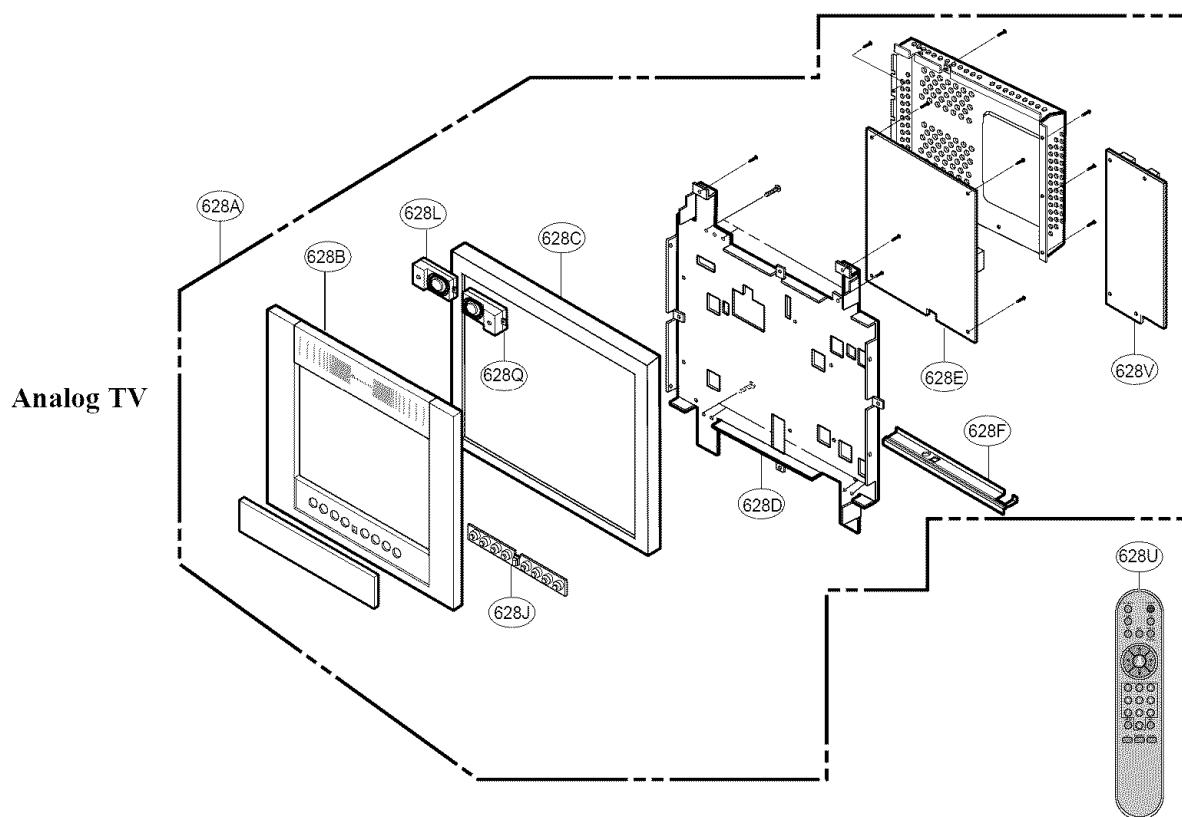



P/No. 3828JD8985A

JAN., 2006 Printed in Korea