

**PERFORMANCE DATA
NO LOAD AND NO DOOR OPENINGS AT MID-POINT CONTROL SETTING**

Type A With Run/Start Capacitor	65°F (18°C) Ambient	90°F (32°C) Ambient
Operating Time	32 to 40%	55 to 65%
Freezer Temperature	0° to 4°F -18° to -16°C	-1° to 3°F -18° to -16°C
Refrigerator Temperature	34° to 39°F 1° to 4°C	34° to 39°F 1° to 4°C
Low Side Pressure (cut-in)	5 to 12 psig 34 to 83 kPa	5 to 12 psig 34 to 83 kPa
Low Side Pressure (cut-out)	-2 to 2 psig -14 to 14 kPa	-2 to 2 psig -14 to 14 kPa
High Side Pressure (Last 1/3 of cycle)	90 to 115 psig 621 to 793 kPa	130 to 155 psig 896 to 1069 kPa
Wattage (Last 1/3 of cycle)	120 to 150	130 to 160
Amps (Running)	1.2 to 1.5	1.2 to 1.5
Base Voltage	115 VAC	115 VAC

DEFROST SPECIFICATIONS

Cabinet Size	Thermostat		Heater	
	Cut-in	Cut-out	Watts	Ohms
23' & 26'	25°F -4°C	47°F 8°C	450	30

Electronic Timer - (ADC) Defrost 24 minutes every 6 to 72 hours of compressor run time.

CONDENSER FAN MOTOR

Watts	RPM	Amps
7	1100 CW Opposite Shaft	.1 Running

ICE MAKER SPECIFICATIONS

Electrical	115 Volts	60 Hertz
Thermostat	Opens at 48°F (9°C)	Closes at 15°F (-9°C)
Heater Wattage	165	

ICE MAKER CONNECTOR PLUG CONNECTIONS

Wire Number	Wire Color	Connects to:
1	Green/Yellow	Ground
2	Yellow	Water Valve
3	Black	Line
4	Lt. Blue	Neutral

SERVICE DATA SHEET - 240389606

**R134a
ICE & WATER - AUTOMATIC DEFROST
SIDE BY SIDE MODELS**

IMPORTANT SAFETY NOTICE

The information provided herein is designed to assist qualified repair personnel only. Untrained persons should not attempt to make repairs due to the possibility of electrical shock. Disconnect power cord before servicing.

IMPORTANT

If any green grounding wires are moved during servicing, they must be returned to their original position and properly secured.

CAUTION: All electrical parts and wiring must be shielded from torch flame. Do not allow torch to contact insulation; it will char at 200°F and flash ignite (burn) at 500°F. Excessive heat will distort the plastic liner.

NOTE: This product comes equipped with an Electronic Defrost Control. To initiate defrost, depress the fresh food light switch 5 times in 6 seconds (light bulb must be working). To terminate defrost, depress the fresh food light switch 5 times in 6 seconds.

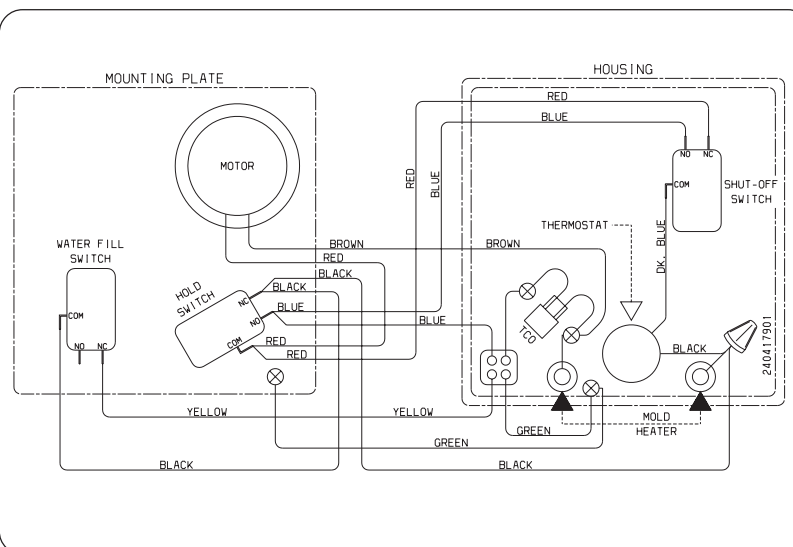

ICE MAKER INFORMATION

Test Cycling

Remove cover by inserting screwdriver in notch at bottom and prying cover from housing. Use screwdriver to rotate motor gear counterclockwise until holding switch circuit is completed. All components of ice maker should function to complete the cycle.

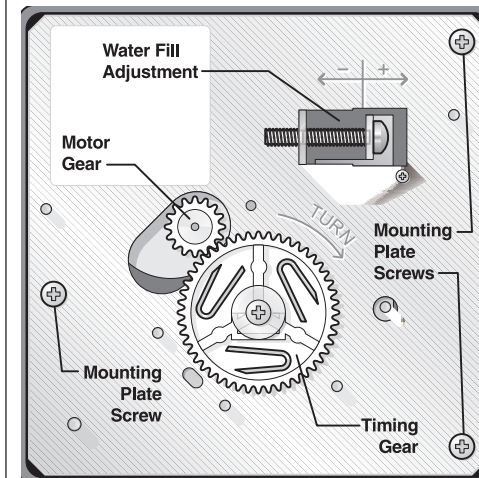

Water Fill Volume

The water fill adjustment screw will change the fill time. One full turn is equal to 20cc (.68 oz.). The correct fill is 102 to 130cc (3.4 to 4.3 oz.). When a water valve is replaced, the fill volume must be checked.

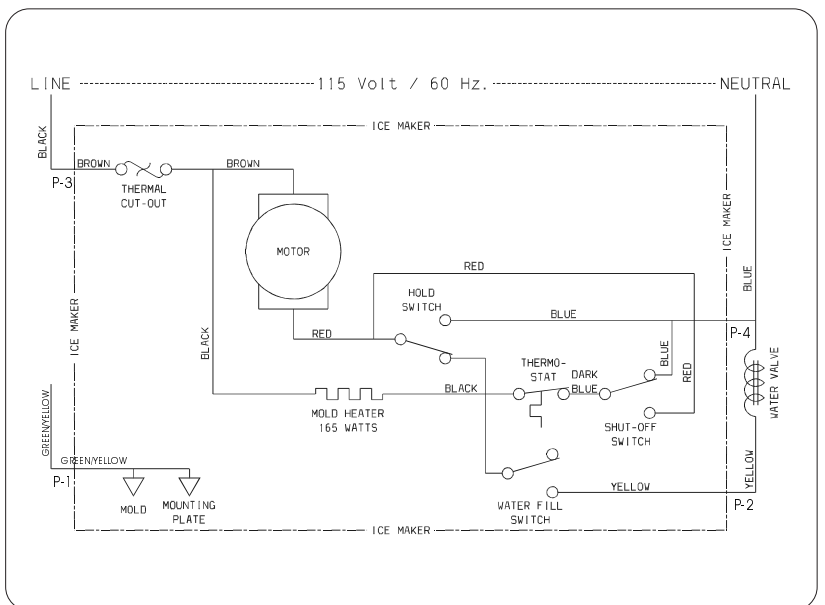

Pictorial Schematic

5.50

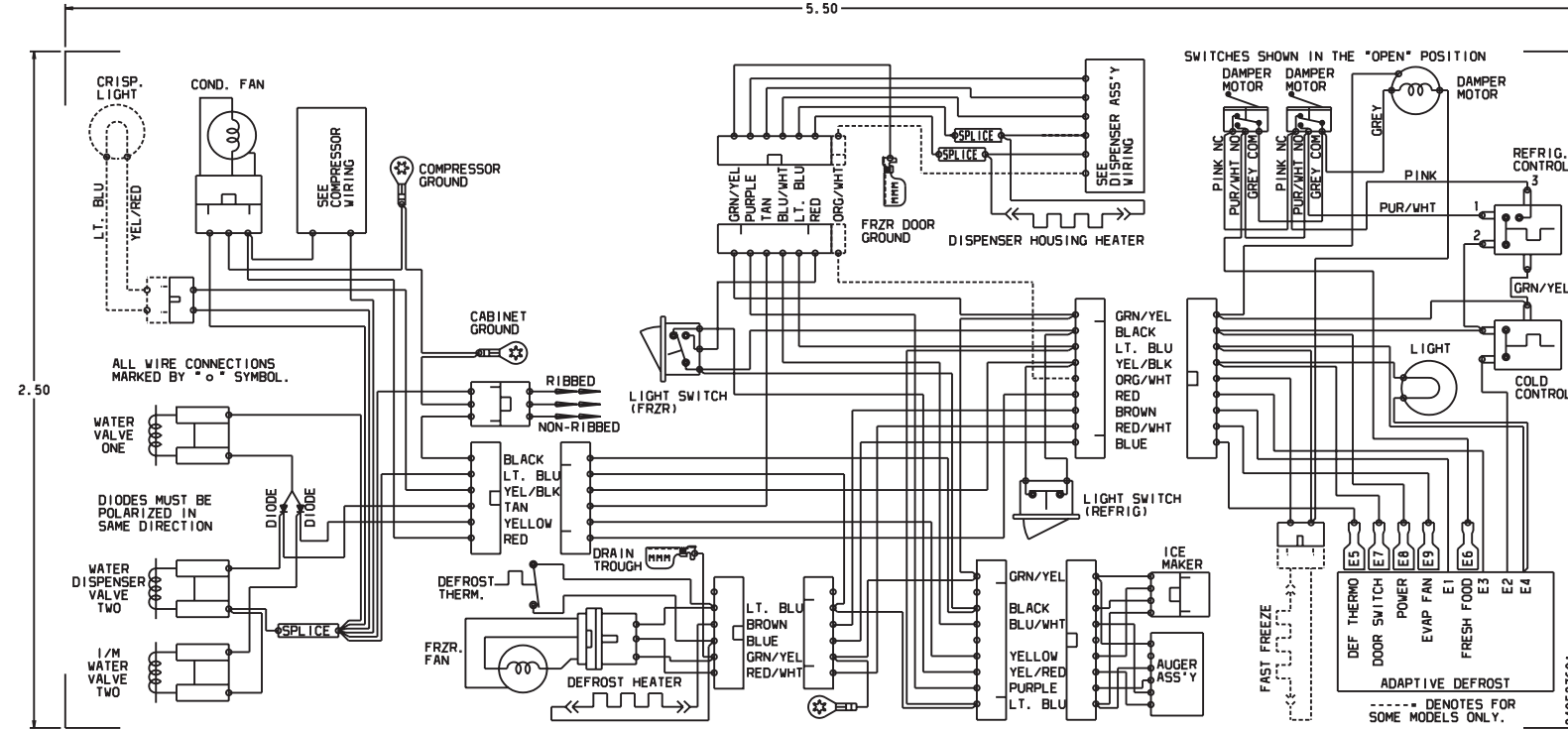

2.50

- BLU/WHT (CUBE)
- RED/BLK (120 VAC)
- PURPLE (AUGER)
- LT. BLUE (NEUTRAL)
- TAN (WATER VALVE)
- ORG/WHT (FAST FREEZE/ICE)

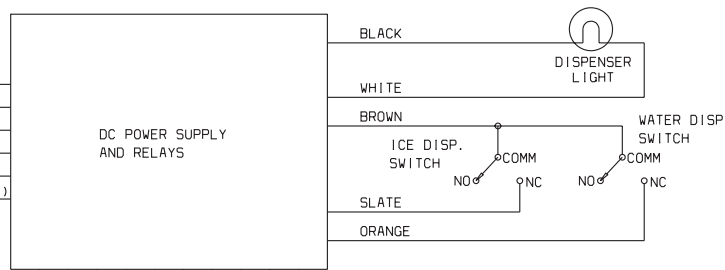

Electronic Dispenser

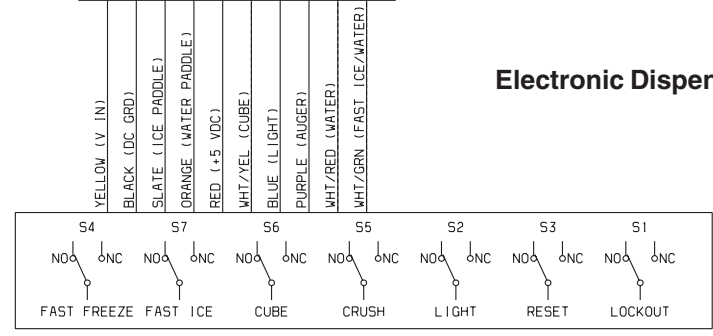

Electro-Mechanical Dispenser

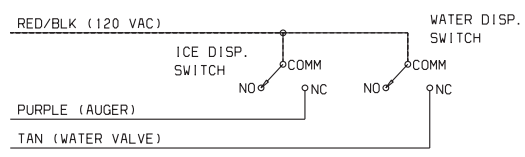

Compressor Wiring

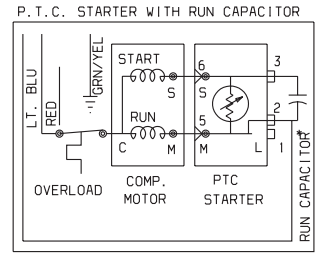

* CAPACITOR IS ONLY USED WITH SOME P. T. C. MODELS.

Ladder Schematic

