

---

# OWNER'S GUIDE

---

## READ AND SAVE THESE INSTRUCTIONS

Record the Model No. and Serial No. of this freezer in the space provided below.

Model No. \_\_\_\_\_

Serial No. \_\_\_\_\_

Keep these numbers for future reference.

**IMPORTANT:** Keep a copy of your bill of sale. The date on the bill establishes the warranty period should service be required. If service is performed, it is in your best interest to obtain and keep all receipts.

### Contents

- 2 Important Safety Instructions
- 3 First Steps
- 4 Setting the Temperature Control
- 4-5 Freezer Optional Features
- 5-6 Care and Cleaning
- 7 Power Failure/Freezer Failure
- 7 Energy Saving Ideas
- 8-9 Avoid Service Checklist
- 10 Warranty in the United States

This Owner's Guide provides specific operating instructions for your model. Use the freezer only as instructed in this Owner's Guide.

### Versión en español

Si desea obtener una copia en español de este Manual del Usuario, sírvase escribir la dirección que se incluye a continuación. Solicite la P/N 216875100.

Spanish Owner's Guides  
Electrolux Home Products  
P. O. Box 212378  
Augusta, GA 30917

# FREEZER

# Important Safety Instructions

## Proper Disposal of Your Refrigerator/Freezer

**⚠ WARNING** Risk of child entrapment. Child entrapment and suffocation are not problems of the past. Junked or abandoned refrigerators or freezers are still dangerous—even if they will sit for “just a few days.” If you are getting rid of your old refrigerator or freezer, please follow the instructions below to help prevent accidents.

### **BEFORE YOU THROW AWAY YOUR OLD REFRIGERATOR/FREEZER:**

\*Remove doors.

\*Leave shelves in place so children may not easily climb inside.

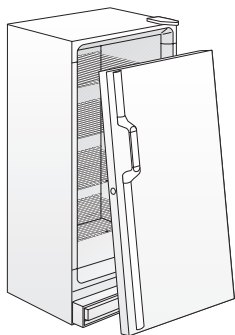

**⚠ WARNING** Avoid fire hazard or electric shock. Do not use an extension cord or an adapter plug. Do not remove any prong from the power cord.

Grounding type wall receptacle



Do not under any circumstances cut, remove, or bypass the grounding prong from this plug.

Power supply cord with 3-prong grounding plug



## Read all instructions before using this freezer.

### **⚠ WARNING** For Your Safety

Do not store or use gasoline or other flammable vapors and liquids in the vicinity of this or any other appliance. Read product labels for flammability and other warnings.

### **⚠ WARNING** Child Safety

- Destroy carton, plastic bags, and any exterior wrapping material immediately after the freezer is unpacked. Children should never use these items for play. Cartons covered with rugs, bedspreads, plastic sheets or stretch wrap may become airtight chambers and can quickly cause suffocation.
- **A child might suffocate if he crawls into a freezer to hide or play.** See Proper Freezer Disposal left. Many communities have laws requiring you to take this safety precaution.
- Remove and discard any spacers used to secure the shelves during shipping. Small objects are a choke hazard to children.

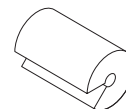

### **⚠ WARNING** Electrical Information

**These guidelines must be followed to ensure that safety mechanisms in the design of this freezer will operate properly.**

- **Refer to the serial plate for correct electrical rating.** The power cord of the appliance is equipped with a three-prong grounding plug for protection against shock hazards. It must be plugged directly into its own properly grounded three-prong receptacle, protected with a 15 amp time delay fuse or circuit breaker. The receptacle must be installed in accordance with the local codes and ordinances. Consult a qualified electrician. Receptacles with Ground Fault Circuit Interrupters (GFCI) are NOT RECOMMENDED. **DO NOT use an extension cord or an adapter plug.**
- If voltage varies by 10 percent or more, freezer performance may be affected. Operating the freezer with insufficient power can damage the motor. Such damage is not covered under the warranty. If you suspect your household voltage is high or low, consult your power company for testing.
- To prevent the freezer from being turned off accidentally, do not plug the unit into an outlet controlled by a wall switch or pull cord.
- Do not pinch, knot, or bend the power cord in any manner.

### **⚠ WARNING** Other Precautions

- Never unplug the freezer by pulling on the power cord. Always grip the plug firmly and pull straight out from the receptacle.
- Turning the control to OFF turns off the compressor, but does not disconnect power to other electrical components.

## First Steps

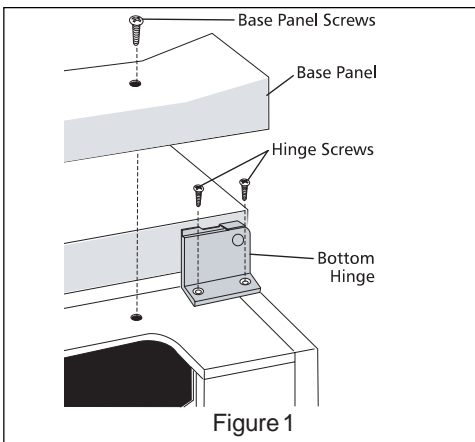
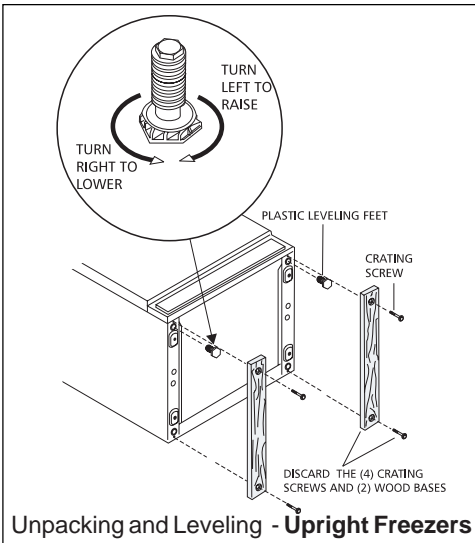
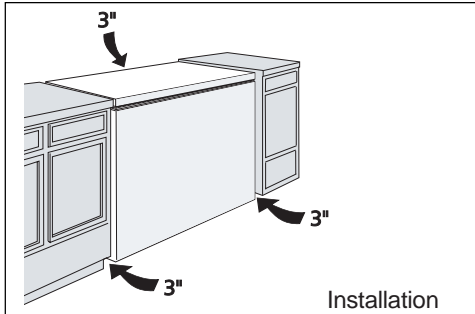

**CAUTION** To allow door to close and seal properly, DO NOT let food packages extend past the front of shelves.

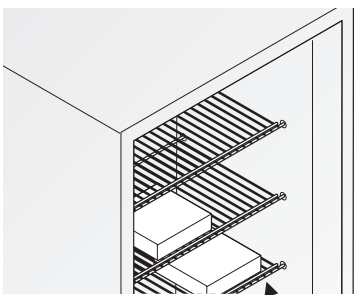

Shelf Front

Before starting the freezer, follow these important first steps:

### Installation

- Choose a place that is near a grounded electrical outlet.
- For the most efficient operation, the freezer should be located where surrounding temperatures will not exceed 110°F (43°C). Temperatures of 32°F (0°C) and below will NOT affect freezer operation. Additional compressor heaters are not recommended.
- Allow space around the unit for good air circulation. Leave a 3 inch (75 mm) space on all sides of the freezer for adequate circulation.

### Leveling

The freezer must have all bottom corners resting firmly on a solid floor. The floor must be strong enough to support a fully loaded freezer. Check the cabinet with a level from side to side. After discarding the crating screws and wood base, level the cabinet.

#### To Level Upright Unit:

Once leveled, slightly raise adjustment of front feet so the door closes easily when opened about halfway.

#### To Level Chest Unit:

If needed, add metal or wood shims between feet pads and floor.

### Cleaning

- Wash any removable parts, the freezer interior, and exterior with mild detergent and warm water. Wipe dry. **DO NOT USE HARSH CLEANERS ON THESE SURFACES.**
- Do not use razor blades or other sharp instruments, which can scratch the appliance surface when removing adhesive labels. Any glue left from the tape can be removed with a mixture of warm water and mild detergent, or touch the residue with the sticky side of tape already removed. **DO NOT REMOVE THE SERIAL PLATE.**

### Door Removal (upright models)

If door must be removed to fit through narrow doorways:

1. Gently lay freezer on its back, on a throw rug or blanket.
2. Remove base panel (some models) by unscrewing two screws from front of base panel. (Figure 1)
3. At top of cabinet, remove plastic top hinge cover.
4. Remove screws from top hinge.
5. Remove top hinge from cabinet. Lift door off lower hinge pin.
6. After door is removed, remove the two screws from bottom hinge.
7. To replace door, reverse above order, and securely tighten all screws to prevent hinge slippage.

## Setting the Temperature Control

### Cool Down Period

For safe food storage, allow 4 hours for the freezer to cool down completely. The freezer will run continuously for the first several hours. Foods that are already frozen may be placed in the freezer after the first few hours of operation. Unfrozen foods should NOT be loaded into the freezer until the freezer has operated for 4 hours.

When loading the freezer, freeze only 3 pounds of fresh food per cubic foot of freezer space at one time. Distribute packages to be frozen evenly throughout the freezer. It is not necessary to turn the control knob to a colder setting while freezing food.

### Temperature Control

The temperature control is located inside the freezer on upright models, and on the left outside wall on chest models. The temperature is factory preset to provide satisfactory food storage temperatures. However, the temperature control is adjustable to provide a range of temperatures for your personal satisfaction. If a colder temperature is desired, turn the temperature control knob to coldest and allow several hours for temperatures to stabilize between adjustments.

## Freezer Optional Features

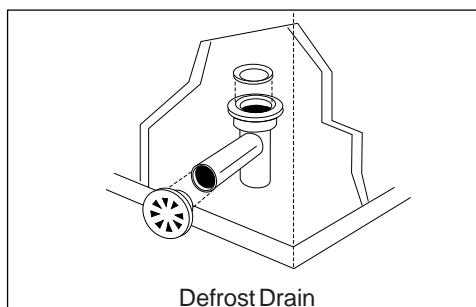
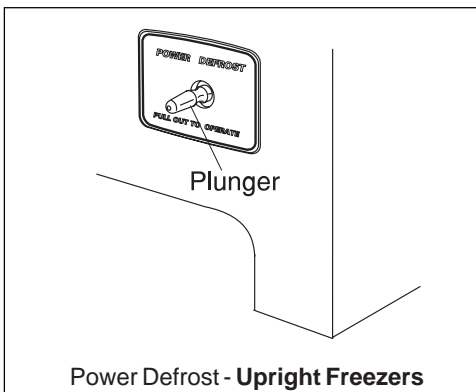
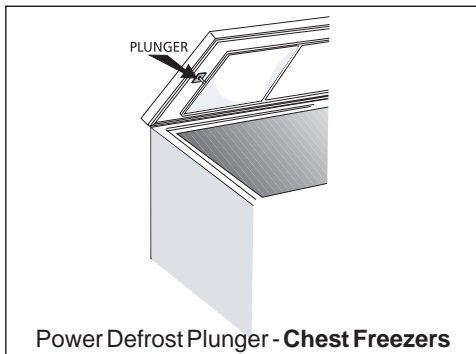

**NOTE: Your freezer may have some, or all of the features listed below. Become familiar with these features, and their use and care.**

### Power On Light

The Power On Light indicates that the freezer is properly connected to electrical power. The light glows even when the temperature control is turned to OFF. If the light goes out, refer to "Freezer does not run" in the Avoid Service Checklist.

### Juice Can Rack (upright models)

The Juice Can Rack on the freezer door is specially ridged to store juice cans and prevent them from rolling out of the shelf.

### Security Lock with Pop-Out Key

This security lock fastens the door snugly, ensuring stored food is secure. To lock or unlock the freezer, push the key into the lock and turn. The key pops out of the lock after it has been turned.

### Power Defrost

The Power Defrost feature will defrost freezer in a fraction of the time usually required. To defrost, **remove all food**, and follow these steps.

1. Pull out Power Defrost Plunger. Leave door open while defrosting. (Closing freezer door will push in plunger and power defrost will be turned off.)
2. Push Power Defrost Plunger in to restart freezer after defrosting is completed.

### Defrost Drain

The Defrost drain provides a method of draining water during defrosting and cleaning. See "Defrosting" in Care and Cleaning Section.

### Interior Light

The light comes on automatically when the door is opened. To replace the light bulb, turn the temperature control to OFF and unplug the electrical cord. Replace the old bulb with a bulb of the same wattage.

### Slide-Out Basket (upright models)

The slide-out basket at the bottom of the freezer provides separate storage space for items that are difficult to store on freezer shelves. To remove the basket, pull out and lift up.

## Freezer Optional Features (continued)

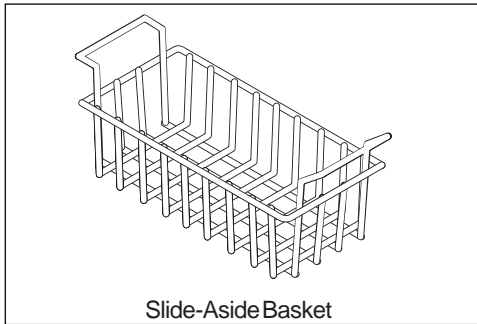

### Slide-Aside Basket (chest models)

This basket helps organize odd-shaped items. To reach other packages in the freezer, slide the basket aside or lift out.

### Fast Freezing Shelves (upright models)

These shelves contain cooling coils to freeze foods quickly and allow cold air to constantly circulate throughout the freezer. Do not use sharp metal objects such as ice picks or scrapers to clean the shelves. This could damage the shelves and reduce their cooling ability. These shelves are not adjustable.

### Drop Front Shelf (upright models)

The Drop Front Shelf, located at the bottom of the freezer, provides a separate compartment for small irregular shaped items or large, bulky items. Lift the shelf front up and out to remove.

## Care and Cleaning

**CAUTION** Damp objects stick to cold metal surfaces. Do not touch interior metal surfaces with wet or damp hands.

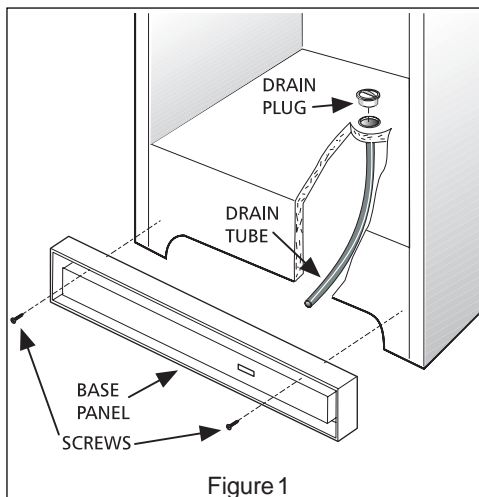

Some upright freezers are frost-free and defrost automatically, but should be cleaned occasionally. Before cleaning or defrosting, unplug the power cord from the electrical outlet.

### Between Defrostings

To avoid frequent defrosting, occasionally use a plastic scraper to remove frost. Scrape with a pulling motion. Never use a metal instrument to remove frost.

### Defrosting

It is important to defrost and clean the freezer when 1/4 to 1/2 inch of frost has accumulated. Frost may tend to accumulate faster on the upper part of the freezer due to warm, moist air entering the freezer when the door is opened. Remove food and leave the door open when defrosting the freezer.

- **On upright models** with a defrost drain (Figure 1), remove the drain plug on the inside floor of the freezer by pulling straight out. To access the external drain tube on models with a base panel, first remove the two screws from the base panel. Locate the drain tube near the left center under the freezer. Place a shallow pan under the drain tube. Defrost water will drain out. Check pan occasionally so water does not overflow. Replace the drain plug when defrosting and cleaning are completed. If the drain is left open, warm air may enter the freezer.
- **On chest models** with a defrost drain, place a shallow pan beneath the drain outlet (Figure 2). A one half inch garden hose adapter can be used to drain the freezer directly into a floor drain (Figure 3). If your model is not equipped with an adapter, one can be purchased at most hardware stores. Pull out the drain plug inside the freezer, and pull off the outside defrost drain plug (Figure 4 on following page). Defrost water will drain out. Check pan occasionally so water does not overflow. Replace the drain plugs when defrosting is completed.

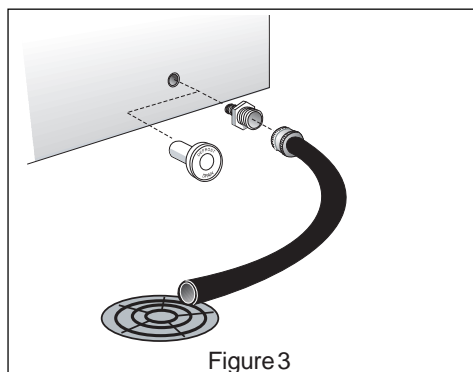
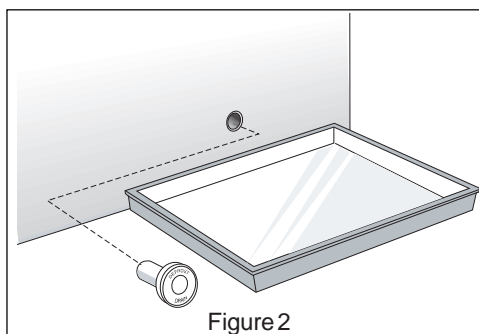

## Care and Cleaning (continued)

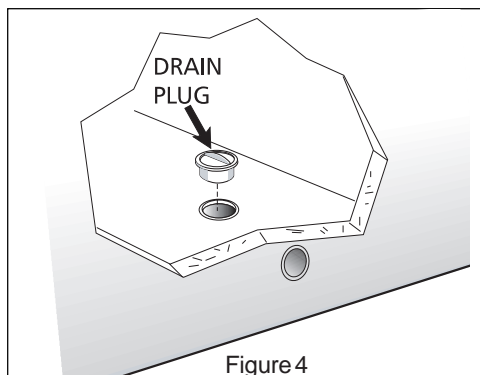

**⚠ WARNING** If leaving the freezer door open while on vacation, make certain that children cannot get into the freezer and become entrapped.

- **On models without a defrost drain**, place towels or newspapers on the freezer bottom to catch the frost. The frost will loosen and fall. Remove towels and/or newspapers.
- If the frost is soft, remove by using a plastic scraper. If frost is glazed and hard, fill deep pans with hot water and place them on the freezer bottom. Close the freezer door. Frost should soften in about 15 minutes. Repeat this procedure if necessary.

### Cleaning the Inside

After defrosting, wash inside surfaces of the freezer with a solution of two tablespoons of baking soda in one quart (1.136 litres) warm water. Rinse and dry. Wring excess water out of the sponge or cloth when cleaning in the area of the controls, or any electrical parts.

Wash the removable parts and door gasket with the baking soda solution mentioned above, or mild detergent and warm water. Rinse and dry. **Never** use metallic scouring pads, brushes, abrasive cleaners, or alkaline solutions on any surface. Do not wash removable parts in a dishwasher.

### Cleaning the Outside

Wash the cabinet with warm water and mild liquid detergent. Rinse well and wipe dry with a clean soft cloth. Replace parts and food.

### Vacation and Moving Tips

**Short Vacations:** Leave the freezer operating during vacations of less than three weeks.

**Long Vacations:** If the freezer will not be used for several months, remove all food and unplug the power cord. Clean and dry the interior thoroughly. To prevent odor and mold growth, leave the freezer door open slightly, blocking it open if necessary.

**Moving:** Disconnect the power cord plug from the wall outlet. Remove foods, then defrost, and clean the freezer. Secure all loose items such as base panel, baskets, and shelves by taping them securely in place to prevent damage. In the moving vehicle, secure freezer in an upright position, and secure to prevent movement. Also protect outside of freezer with a blanket, or similar item.

---

## Power Failure/ Freezer Failure

Do not open freezer door unnecessarily if freezer is off for several hours.

**If a power failure occurs**, frozen foods will stay frozen for at least 24 hours if the freezer is kept closed. If the power failure continues, pack seven or eight pounds of dry ice into the freezer every 24 hours. Look in the Yellow Pages under "Dry Ice," "Dairies," or "Ice Cream Manufacturers" for local dry ice suppliers. Always wear gloves and use caution when handling dry ice.

**If the freezer has stopped operating**, see "Freezer does not run" in the Avoid Service Checklist Section of this manual. If you cannot solve the problem, call an authorized servicer immediately.

If the freezer remains off for several hours, follow the directions above for the use of dry ice during a power failure. If necessary, take the food to a local locker plant until the freezer is ready to operate. Look in the Yellow Pages under "Frozen Food Locker Plants."

---

## Energy Saving Ideas



- The freezer should be located in the coolest area of the room, away from heat producing appliances or heating ducts, and out of direct sunlight.
- Let hot foods cool to room temperature before placing in the freezer. Overloading the freezer forces the compressor to run longer. Foods that freeze too slowly may lose quality, or spoil.
- Be sure to wrap foods properly, and wipe containers dry before placing them in the freezer. This cuts down on frost build-up inside the freezer.
- Freezer shelves should not be lined with aluminum foil, wax paper, or paper toweling. Liners interfere with cold air circulation, making the freezer less efficient.
- Organize and label food to reduce door openings and extended searches. Remove as many items as needed at one time, and close the door as soon as possible.

# Avoid Service Checklist

Before calling for service, review this list. It may save you both time and expense. This list includes common occurrences that are not the result of defective workmanship or materials in this appliance.

## OCCURRENCE

## SOLUTION

### **FREEZER DOES NOT RUN**

Check to be sure freezer is not plugged into a circuit that has ground fault interrupt. If you are unsure about the outlet, have it checked by a certified technician.

Temperature control is in the OFF position. See Setting the Temperature Control Section.

Freezer may not be plugged in, or plug may be loose. Be sure plug is tightly pushed into electrical outlet.

House fuse has blown, or circuit breaker has tripped. Check/reset circuit breaker, or replace fuse with 15 amp. time delay fuse.

Power outage. Check house lights. Call local electric company.

### **Freezer runs too much or too long.**

Room or outside weather is hot. It is normal for the freezer to work harder under these conditions.

Freezer had recently been disconnected for a period of time. Freezer requires 4 hours to cool down completely.

Large amounts of warm or hot food have been stored recently. Warm food will cause the freezer to run more until the desired temperature is reached.

Door is kept open too long or too frequently. Warm air enters the freezer every time the door is opened. Open the door less often.

Freezer door may be slightly open. See Occurrence "Door Problems."

Temperature control is set too cold. Turn the control knob to a warmer setting. Allow several hours for the temperature to stabilize.

Freezer gasket is dirty, worn, cracked, or poorly fitted. Clean or change gasket. Leaks in the door seal will cause freezer to run longer in order to maintain desired temperature.

### **Temperatures inside the freezer are too cold.**

Temperature control is set too cold. Turn the control to a warmer setting. Allow several hours for the temperature to stabilize.

### **Temperatures inside the freezer are too warm.**

Temperature control is set too warm. Turn the control to a colder setting. Allow several hours for the temperature to stabilize.

Door is kept open too long or is opened too frequently. Warm air enters the freezer every time the door is opened. Open the door less often.

Door may be open slightly. See Occurrence section "Door Problems."

Large amounts of warm or hot food might have been stored recently. Wait until the freezer has had a chance to reach its selected temperature.

Freezer has recently been disconnected for a period of time. Freezer requires 4 hours to cool down completely.

### **Temperature of external freezer surface is warm.**

The exterior freezer walls can be as much as 30°F warmer than room temperature. This is normal while the compressor works to transfer heat from inside the freezer cabinet.

## **SOUND AND NOISE**

### **Louder sound levels whenever freezer is on.**

Modern freezers have increased storage capacity and more even temperatures. They require a high efficiency compressor. When the surrounding noise level is low, you might hear the compressor running while it cools the interior.

### **Louder sound levels when compressor comes on.**

Freezer operates at higher pressures during the start of the ON cycle. This is normal. Sound will level off or disappear as freezer continues to run.

### **Popping or cracking sound when compressor comes on.**

Metal parts undergo expansion and contraction, as in hot water pipes. This is normal. Sound will level off or disappear as freezer continues to run.



**OCCURRENCE****SOLUTION****SOUND AND NOISE (cont'd)**

---

**Bubbling or gurgling sound, like water boiling.**

Refrigerant (used to cool freezer) is circulating throughout the system. This is normal.

---

**Vibrating or rattling noise.**

Freezer is not level. It rocks on the floor when it is moved slightly. Level the unit. Refer to "Leveling" in the First Steps Section.

---

Floor is uneven or weak. Freezer rocks on the floor when it is moved slightly. Be sure floor can adequately support freezer. Level the freezer by putting wood or metal shims under part of the freezer.

---

**WATER/MOISTURE/FROST INSIDE FREEZER**

---

Freezer is touching the wall. Relevel the freezer or move freezer slightly. Refer to "Leveling" in the First Steps Section.

---

**Moisture forms on inside freezer walls.**

Weather is hot and humid, which increases internal rate of frost build-up. This is normal.

---

Door is slightly open. See Occurrence "Door Problems."

---

**WATER/MOISTURE/FROST OUTSIDE FREEZER**

---

Door is kept open too long, or is opened too frequently. Open the door less often.

---

**Moisture forms on outside of freezer.**

Door is slightly open, causing the cold air from inside the freezer to meet warm moist air from outside. See "Door Problems" in the Occurrence Section.

---

**ODOR IN FREEZER**

---

Interior needs to be cleaned. Clean interior with sponge, warm water, and baking soda.

---

**DOOR PROBLEMS**

---

Foods with strong odors are in the freezer. Cover the food tightly.

---

**Door will not close.**

Freezer is not level. It rocks on the floor when it is moved slightly. This condition can force the cabinet out of square and misalign the door. Refer to "Leveling" in the First Steps Section.

---

Floor is uneven or weak. Freezer rocks on the floor when it is moved slightly. Level the floor by using metal or wood shims under the freezer or brace floor supporting the freezer.

---

**LIGHT BULB IS NOT ON**

---

Light bulb is burned out. Follow directions under "Interior Light" in the Freezer Features Section.

---

No electric current is reaching the freezer. See Occurrence "Freezer Does Not Run."

---

# **FREEZER WARRANTY**

Your freezer is protected by this warranty

|   | <b>WARRANTY PERIOD</b>                                    | <b>THROUGH OUR AUTHORIZED SERVICERS, WE WILL:</b>   | <b>THE CONSUMER WILL BE RESPONSIBLE FOR:</b>  |
|---|---|---|---|
| <b>FULL ONE-YEAR WARRANTY</b>   | One year from original purchase date                      | Pay all costs for repairing or replacing any parts of this appliance which prove to be defective in materials or workmanship.   | Costs of service calls that are listed under <b>NORMAL RESPONSIBILITIES OF THE CONSUMER.</b> *  |
| <b>LIMITED 2<sup>ND</sup>-5<sup>TH</sup> YEAR WARRANTY (Sealed System)</b>    | Second through fifth years from original purchase date    | Repair or replace any parts in the Sealed Refrigeration System (compressor, condenser, evaporator, drier and tubing) which prove to be defective in materials or workmanship, and provide the labor to install such part.   | Diagnostic costs and any removal, transportation and reinstallation costs, which are required because of service. Costs for labor, parts and transportation other than with respect to the Sealed Refrigeration System. |
| <b>LIMITED 6<sup>TH</sup>-10<sup>TH</sup> YEAR WARRANTY (Compressor Only)</b> | Sixth through tenth years from original purchase date     | Provide a replacement for any compressor, which proves to be defective in materials or workmanship.   | Diagnostic costs and any removal, transportation and reinstallation costs, which are required because of service. Costs for labor, parts and transportation other than the cost of the replacement compressor itself.   |
| <b>LIMITED WARRANTY (Applicable to the State of Alaska)</b>                   | Time periods listed above.                                | All of the provisions of the full and limited warranties above and the exclusions listed below apply.   | Costs of the technician's travel to the home and any costs for pick up and delivery of the appliance required because of service.   |
| <b>THREE-YEAR LIMITED FOOD SPOILAGE PLAN</b>                                  | During the first three years from original purchase date. | If food loss results because of defects in materials or workmanship during the time periods listed above, and applies to the limitations stated in the normal responsibilities of the consumer listed below, <b>Electrolux will reimburse the consumer for the actual food spoilage loss in excess of \$5.00 per occurrence, but not to exceed a cumulative maximum payment of \$100.00</b> , provided the food losses:<br>A) Are reported and the food shown to any Electrolux authorized servicer within 24 hours of the discovery of the loss.<br>B) Are not occasioned by either the manual disconnection of the electrical power within the premises of the owner or a general power failure.<br>C) Occur even though the owner exercised reasonable care and diligence to save food per suggestions furnished with the appliance. |   |

In the U.S.A., your appliance is warranted by Electrolux Home Products, Inc. We authorize no person to change or add to any of our obligations under this warranty. Our obligations for service and parts under this warranty must be performed by us or an authorized Electrolux Home Products, Inc. servicer. In Canada, your appliance is warranted by Electrolux Canada Corp.

**\*NORMAL RESPONSIBILITIES OF THE CONSUMER**

**This warranty applies only to products in ordinary household use, and the consumer is responsible for the items listed below:**

1. Proper use of the appliance in accordance with instructions provided with the product.
2. Proper installation by an authorized servicer in accordance with instructions provided with the appliance and in accordance with all local plumbing, electrical and/or gas codes.
3. Proper connection to a grounded power supply of sufficient voltage, replacement of blown fuses, repair of loose connections or defects in house wiring.
4. Expenses for making the appliance accessible for servicing, such as removal of trim, cupboards, shelves, etc., which are not a part of the appliance when it was shipped from the factory.
5. Damages to finish after installation.
6. Replacement of light bulbs and/or fluorescent tubes (on models with these features).

**EXCLUSIONS**

**This warranty does not cover the following:**

1. CONSEQUENTIAL OR INCIDENTAL DAMAGES SUCH AS PROPERTY DAMAGE AND INCIDENTAL EXPENSES RESULTING FROM ANY BREACH OF THIS WRITTEN OR ANY IMPLIED WARRANTY. **NOTE:** Some states do not allow the exclusion or limitation of incidental or consequential damages, so this limitation or exclusion may not apply to you.
2. Service calls which do not involve malfunction or defects in workmanship or material, or for appliances not in ordinary household use. The consumer shall pay for such service calls.
3. Damages caused by services performed by servicers other than Electrolux Home Products, Inc. or its authorized servicers; use of parts other than genuine Electrolux Home Products, Inc. parts; obtained from persons other than such servicers; or external causes such as abuse, misuse, inadequate power supply or acts of God.
4. Products with original serial numbers that have been removed or altered and cannot be readily determined.

**IF YOU NEED SERVICE**

Keep your bill of sale, delivery slip, or some other appropriate payment record. The date on the bill establishes the warranty period should service be required. If service is performed, it is in your best interest to obtain and keep all receipts. This written warranty gives you specific legal rights. You may also have other rights that vary from state to state. Service under this warranty must be obtained by contacting Electrolux Home Products, Inc.:

This warranty only applies in the 50 states of the U.S.A., Puerto Rico, and Canada. Product features or specifications as described or illustrated are subject to change without notice. All warranties are made by Electrolux Home Products, Inc. In Canada, your appliance is warranted by Electrolux Canada Corp.

01-U-FR-02 (Rev. 01/2002)

**USA**  
**800•944•9044**  
 Electrolux Home Products, Inc.  
 P.O. Box 212378  
 Augusta, GA 30917

**Canada**  
**866•213•9397**  
 Electrolux Canada Corp.  
 6150 McLaughlin Road  
 Mississauga, Ontario  
 L5R 4C2